

PIAAT

PORTER MANUALS

TIPO AND TEMPRA

ΚΕΡΑΨ ΜΑΨ1Α1. • 5ΕΚΥ1ΣΕ ΣΨΟΕ
& Ομπερ Ξε1ερεπε 1π1ογτα11οπ



HATCHBACK5, 5ΑΙΟΟΝº ΑΝº Ε5ΤΑΤΕ5
1988 - 1996
Ργед - Ρгед 1п 1He ЦК



ΡΟΚΤΕЯ ΡΙΒΙΖΗΤС

making it easy!

ΠΑΤ ΑΡΡΚΟΥΕΟ



SELÉNIA
MOTOR OIL

Fluid levels (if included) are monitored by LEDs f, o and p, indicating the levels of the fluid reservoirs.

A red LED illuminates at the position on the check panel corresponding to a side door or a hatchback/tailgate that is not properly closed.

SIDE AND TAIL LIGHTS

When the side and tail lights are turned on, the check panel monitors the light bulbs, fuses and circuits.

- LED g monitors the front side lights.
- LED i monitors the tail lights.

If one of the two fuses protecting the following bulbs blows, LEDs g, i, and m illuminate.

NUMBER PLATE LIGHTS

- LED m indicates when one or both of the number plate light bulbs have burnt out.

REAR FOG LIGHTS

- When the fog-guard lights are turned on, LED h monitors the light bulbs.
- When the fuse blows or a circuit malfunction occurs, LED h illuminates, but not the panel indicator.

STOP LIGHTS

If one or both stop lights burn out, the fuse blows or a circuit malfunction occurs, LED l or n illuminates when braking.

- LED n monitors the left stop light.
- LED l monitors the right stop light.

If both bulbs burn out at the same time or brake pedal switch malfunction occurs, both LEDs l and n illuminate.

ENGINE OIL LEVEL

- LED f illuminates when the engine oil level is low (key at MAR, engine not running).

The oil level monitoring system does not operate when the engine is running. If the oil level warning LED illuminates when driving, a circuit sensor malfunction has occurred.

When starting the car on a hill or within 10 minutes of switching off the engine the warning light may illuminate (event will be stored in system memory). Start the engine again on level ground to ensure the oil level is sufficient.

COOLANT

A low coolant level is indicated by LED o (key at MAR). The LED also illuminates when a sensor or circuit malfunction occurs.

WINDSCREEN AND REAR SCREEN WASH LEVELS

- LED p illuminates (key at MAR) when the level in the windscreen or rear screen wash reservoirs are low.

- The LED also indicates when a circuit or sensor malfunction occurs.

• 5. HEATING AND VENTILATION CONTROLS

5A. Air volume control - Adjust the dynamic air flow (fan OFF) by turning the knob up to I. Continue turning the knob to the right to increase the air flow (i.e. fan ON).



5B. Air temperature control - The temperature will increase the further you turn the air temperature knob to the right (red zone).

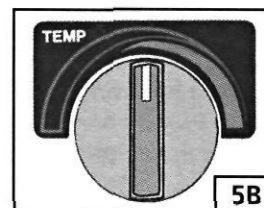

The temperature decreases the further you turn the temperature control knob to the left (blue zone).

HEATING

HEAT DISTRIBUTION

With the air temperature knob (5B) turned to the red zone and the air volume control knob (5A) turned to the desired fan speed, turn the air distribution knob (5C) to:

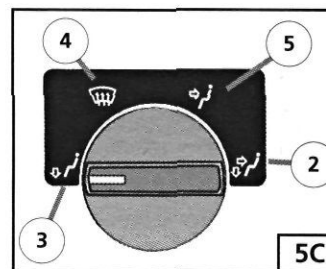

- 2 - In sunny, cold weather.
- 3 - For heating to footwell vents.
- 4 - Demist the windows.
- Also, turn the air volume control knob (5A) to level II or III.

VENTILATION

- Turn the air distribution control to 5.
- Turn the air temperature adjustment knob fully anti-clockwise to the blue zone.
- Turn the air volume control knob to the desired fan speed.
- Turn the air distribution control to 5.

When the car is moving the volume of the air entering the passenger compartment can be reduced by turning the fan knob to the left of 1.

DUAL TEMPERATURE

- Turn the air temperature adjustment knob to an intermediate position.
- Turn the air distribution control knob to 2.

Warmer air is delivered to the footwell vents and cooler air to the dashboard vents.

O **Step 4:** Refill the gearbox with the correct grade and quantity of FL oil. See *Chapter 3, Facts and Figures*.

LI **Step 5:** When the brake calipers have been refitted, pump the brake pedal until its normal solid feel is restored.

LJ **Step 6:** Use a self-grip wrench to reconnect the gear rod balls and sockets. Use new drive-shaft nuts, tightened to the correct torque and staked into the shaft grooves with a punch. See *Job 9*.

Job 3. Clutch - replacement.

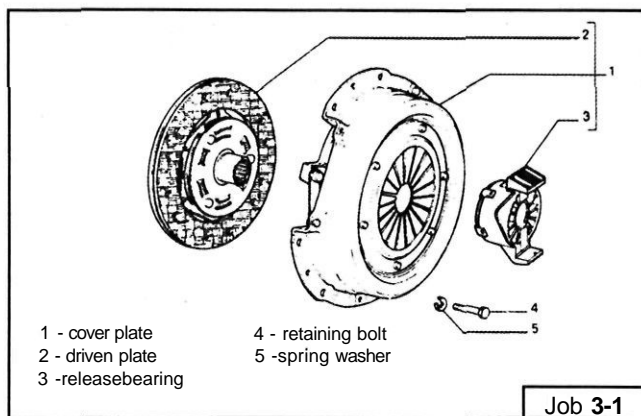

Q **Step 1:** These first three numbered parts are the parts you will need to obtain, from your FIAT dealership.

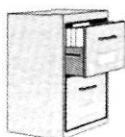

FACT FILE: CLUTCH COMPONENTS

• We strongly recommend that all three main components: clutch cover, driven plate and release bearing are replaced after a high mileage, ensuring longer life and smoother operation.

• If one is worn, they are all likely to be, so save yourself another big stripdown in the near future!

[] **Step 2:** Remove the transmission. See *Job 1*.

Q **Step 3:** Unscrew the clutch cover bolts (see illustration *Job 3-1, part 4*) progressively until the spring pressure is released, then remove the bolts. Ease the cover (*part 1*) off its dowels and catch the driven plate (*part 2*) as it falls.

[I **Step 4:** H INSIDE INFORMATION! Check the inside of the clutch bell housing for contamination by oil. This indicates a leak from either the crankshaft rear seal or the gearbox input shaft seal. Oil can cause judder and slip.

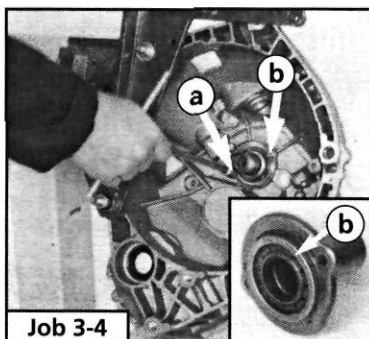

Replace the gearbox seal by removing the screws holding in the thrust bearing sleeve (a), prising out the old and fitting a new seal (b). See *PARTA: Petrol or Diesel*

Section as appropriate, for the replacement of the rear crankshaft seal. Q

• **Step 5:** H INSIDE INFORMATION: Check the inside of the clutch bellhousing for contamination by oil. This indicates a leak from either the crankshaft rear seal or the gearbox input shaft seal (illustrated). A faulty seal should be replaced without delay. Oil can cause judder and slip. Here, the seal (inset) is being replaced. See *PARTA: ENGINE, Job 21* for the position of the rear crankshaft seal. D

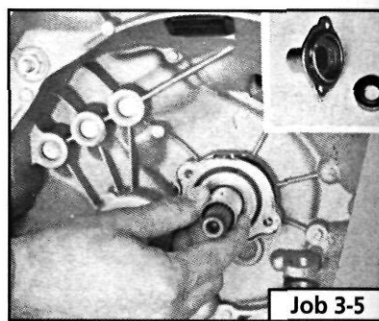

LI **Step 6:** Check the surface of the flywheel that mates with the clutch, for scoring, or significant micro cracking caused by excessive heat generated by clutch slip. Replace the flywheel if in doubt.

• **Step 7:** Check the release fork pivot, inside the bellhousing, for wear. Replace the bushes (see inset) if necessary, lubricating with a small quantity of molybdenum disulphide grease.

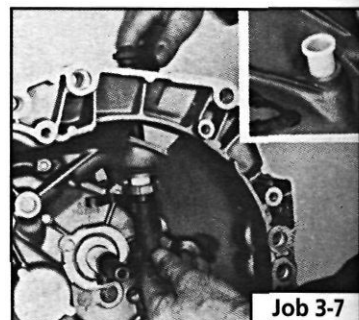

L) **Step 8:** Replace the bush (a) by removing the circlip (b) from the lever shaft (d). Note the position of the arm (c) on the splines for refitting and slide it off. Prise the bush out using a screwdriver. Lubricate the new bush with a small quantity of molybdenum disulphide grease and install. Refit the arm to the fork control shaft (d) with a new circlip. Refit the release bearing (e).

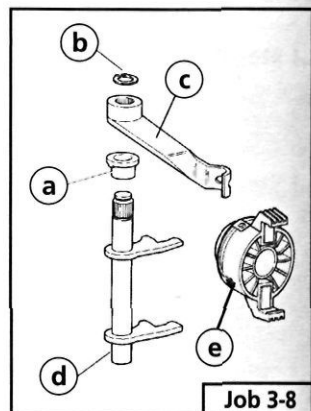

LI **Step 9:** Clean any oil (or the protective film) from the clutch cover and flywheel faces.

LI **Step 10:** Offer the driven plate to the flywheel with the side having the greatest hub projection facing outwards.

L) **Step 11:** Locate the clutch cover on the flywheel dowels and screw in the fixing bolts finger tight.

D **Step 12:** Use an aligning tool to make sure that the clutch is centralised, otherwise the gearbox will not relocate on the engine and damage can be caused to the centre plate.

H INSIDE INFORMATION: There is no spigot bush or bearing in the crankshaft end, but there is an indentation which you can 'feel' with a normal clutch alignment tool allowing you to centralise the driven plate between the clutch cover release fingers. B

LJ Step 13: Tighten the cover bolts evenly to the correct torque. See *Chapter 3, Facts and Figures*.

G Step 14: Smear a little 'copper' grease on the release bearing guide and the gearbox input shaft.

G Step 15: Refit the transmission. See *Job 2*.

Job 4. Clutch cable - replacement.

IMPORTANT NOTE: Later cars have hydraulic clutches - see *Job 14*.

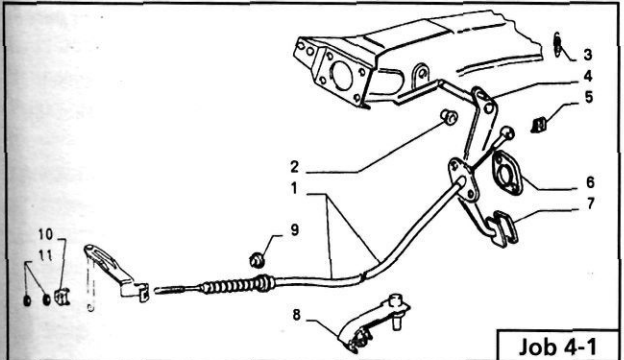

Job 4-1

G Step 1: From under the bonnet, slacken the cable adjusting nut (11). Disconnect the cable from the release lever and outer cable bracket.

G Step 2: From inside the car, disconnect the cable from the foot pedal by removing the securing clip (see illustration *MA4-1, part 5*) and pulling the cable end off its pivot.

G Step 3: Unbolt the cable retaining plate from the bulkhead. Pull the cable out from inside the car.

G Step 4: Fit the new cable in the reverse order and adjust. See *Chapter 5, Servicing Your Car, Job 20*.

Job 5. Gear lever and linkage - removal and refitting.

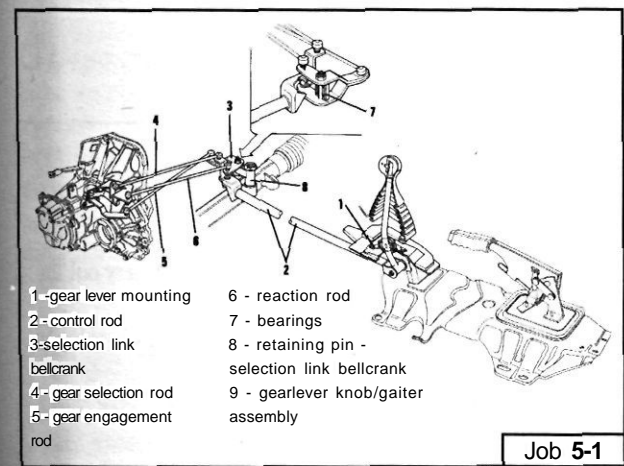

Job 5-1

G Step 1: Familiarise yourself with this drawing, which *Step 2* onwards refers.

G Step 2: Detach the bottom of the gearlever gaiter from its location on the tunnel, (it may be held down from beneath

the car, with securing nuts, or it may be 'worked' in to its housing) then pull the gaiter/knob assembly from the top of the lever. (This is a push fit when refitting.)

Q Step 3: From under the car, undo and remove the nut and bolt securing the control rod (2) from the base of the gearlever.

LJ Step 4: Undo the two bolts securing the gearlever mounting and extract the lever from under the car.

LI Step 5: From under the bonnet, disconnect rods 4, 5 and 6 at the gearbox end by unscrewing them, or by prising the balls from their sockets, according to type.

Q Step 6: Remove the circlip and washer and lift the selection link bellcrank (3) off its retaining pin and remove the complete assembly from the car.

L) Step 7: Inspect all components for wear and replace as necessary, reassembling in the reverse order.

Job 6. Kickdown cable (automatic transmission) - replacement.

L) Step 1: Drain the automatic transmission oil and remove the sump. Discard the old gasket. See *Chapter 5, Servicing Your Car, Job 18*.

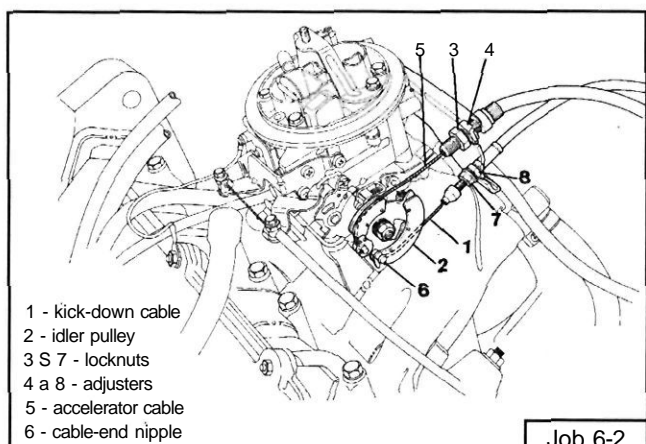

Job 6-2

- 1 - kick-down cable
- 2 - idler pulley
- 3 S 7 - locknuts
- 4 a 8 - adjusters
- 5 - accelerator cable
- 6 - cable-end nipple

Q Step 2: Disconnect the cable from the throttle control idler pulley.

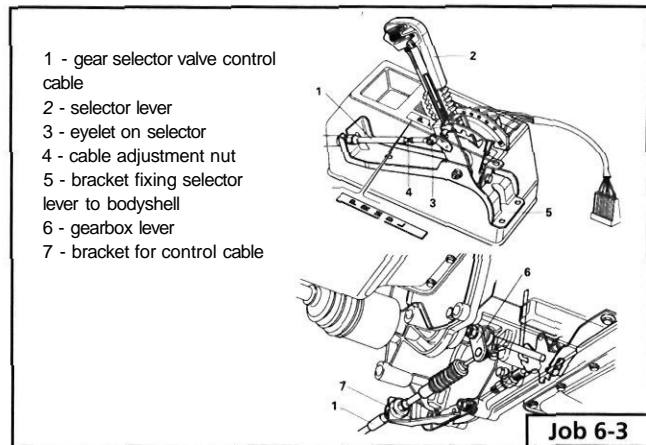

Job 6-3

- 1 - gear selector valve control cable
- 2 - selector lever
- 3 - eyelet on selector
- 4 - cable adjustment nut
- 5 - bracket fixing selector lever to bodyshell
- 6 - gearbox lever
- 7 - bracket for control cable

Q Step 3: Remove the securing clip and disconnect the kickdown cable (1) from the selector (3).

U Step 4: Release the outer cable centring bush from its housing in the gearbox.

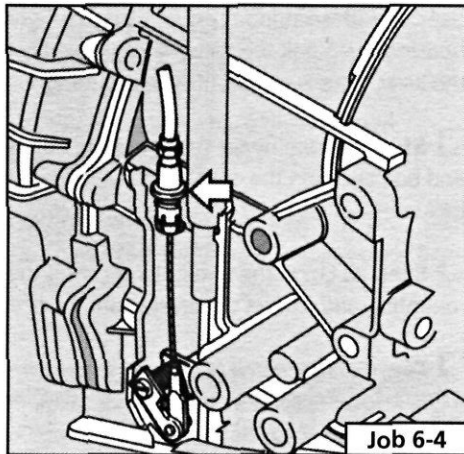

Job 6-4

• **Step 5: Q** **INSIDE INFORMATION!** To do this, you will have to make a simple tool as shown here. There is no FIAT 'special tool' - each dealer has to make this one himself! Use the tool to push lightly upwards, so that the cable centring bush (illustration *Job 6-4* arrowed) comes out of its seat. **H**

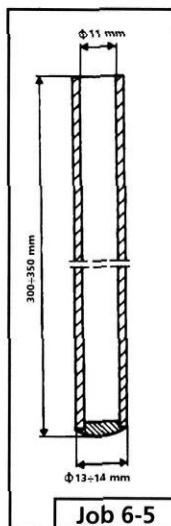

Job 6-5

LJ Step 6: Fit the new cable in the reverse order. Use a new gasket when refitting the sump.

IMPORTANT NOTE: Readjust the cables if necessary. See *Jobs 7 and 8*.

LJ Step 7: Refill the transmission with automatic transmission fluid. See *Chapter 3, Facts and Figures*.

Job 7. Kickdown cable (automatic transmission) - adjustment.

Refer to the illustrations in *Job 6*,

LJ Step 1: Check that the slow running speed is correct and the accelerator cable is correctly adjusted, with just a small amount of slack.

LJ Step 2: Disconnect the kickdown cable from the idler pulley and ensure that it is perfectly free in its operation.

H Step 3: With the selector lever in 'P', start the engine and let it idle.

LJ Step 4: Pull the inner cable by hand until resistance is felt, caused by the compression of the valves. The cable end should now line up with its locating slot in the idler pulley - if not, adjust nuts (7) and (8).

LJ Step 5: Reconnect the cable and then switch off the engine.

LJ Step 6: Check that when the accelerator pedal is hard down, there is 1 mm of further movement left on the kickdown cable, otherwise, make further adjustments on nuts (7) and (8).

Job 8. Automatic gear selector control cable - replacement.

Refer to illustration *Job 6, Step 3*.

LJ Step 1: Raise the car and support it securely on axle stands.

LJ Step 2: Remove the cover from the gear selection mechanism and familiarise yourself with the drawing referred to here.

LJ Step 3: Manually select the 'P' (park) position, using the lever beneath the gearchange (see illustration *Job 6-3, part 6*),

LJ Step 4: Disconnect the cable from the selector eyelet (3) and detach from the slot in the front end of the bracket (5).

Q Step 5: Disconnect the inner cable from the gearlever (6) and release the outer casing from its gearbox mounted bracket (7). Remove the cable.

LJ Step 6: Ensure that 'P' (park) is still engaged by moving the gearlever (6 - beneath the car) fully rearward.

IMPORTANT NOTE: When 'Park' is properly engaged you will not be able to turn both front wheels in the same direction at the same time. This is because the transmission should be 'locked' when 'park' is engaged.

LJ Step 7: Connect the new cable at the bracket (7) and then at the bottom of the gear lever (6).

LJ Step 8: Feed the other end of the cable through to the inside of the car and fix the outer casing into the slot in bracket (5).

LJ Step 9: Put the interior selector lever (2) in the 'P' (park) position and with the inner cable taut, check that the eyelet (3) aligns perfectly with the selector pin.

LJ Step 10: If necessary, slacken the adjustment nut (4) and adjust the position of the eyelet (3) accordingly. Fit the eyelet to the pin and tighten the nut (4).

LJ Step 11: Check that the gears engage in their correct positions on the selector indicator.



FACT FILE: CHECKING AUTO. TRANSMISSION SELECTION

• Now that you have completed the installation, and **BEFORE USING THE VEHICLE ON THE ROAD**, carry out the following check:

- The engine should only start when you have selected either 'P' (park), or 'N' (neutral).
- The gear lever selector positions should agree with those indicated on the display panel.
- When 'R' (reverse) is selected, the reverse light should come on. With the ignition switched off, the buzzer should sound if any position other than 'P' (park) is selected.

LJ Step 12: Refit the selection mechanism cover.

Job 9. Drive-shaft - removal and refitting.

IMPORTANT NOTE: For removal of the diesel Turbo's drive-shaft, see also **PART A: ENGINE, Job 18, Step 16A.**

Q Step 1: Drain the transmission oil.

Q Step 2: Ask a helper to apply the footbrake very firmly while you slacken the drive-shaft-to-hub nut, using a long bar for good leverage after opening out the staking on the nut, as far as possible. **DON'T** do so with the car off the ground because the very large force needed could pull it off its stands. Remove the nut after the car has been raised.

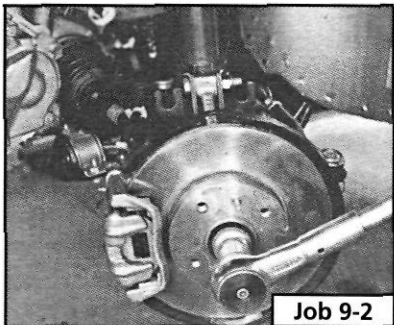

Job 9-2

Q Step 3: Slacken the hub nuts on the side to be worked on. Jack up the front of the car and support on axle stands. Remove the roadwheel.

• Step 4: Unbolt the brake hose support clip from the suspension strut.

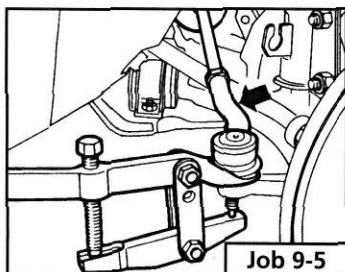

Job 9-5

G Step 5: Disconnect the track rod end from the steering arm using a suitable splitter tool.

Q Step 6: Remove the hub carrier securing bolts (arrowed) from the base of the front suspension strut and tap the carrier down and out of the clamp. Pull the top outwards.

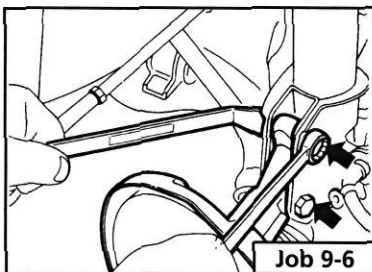

Job 9-6

• Step 7: Push or tap the drive-shaft splines (arrowed) out of the hub carrier, taking care not to damage the thread.

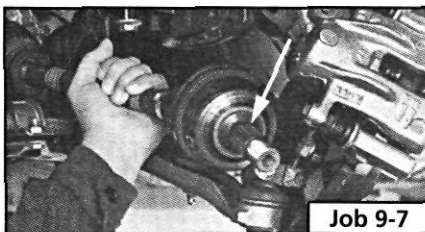

Job 9-7

• Step 8A: Undo the inboard gaiter retaining clip (a) and release the gaiter.

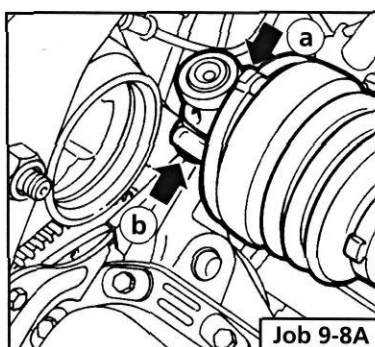

Job 9-8A

• Step 8B: Diesel turbo models have a bolt-on inboard flange.

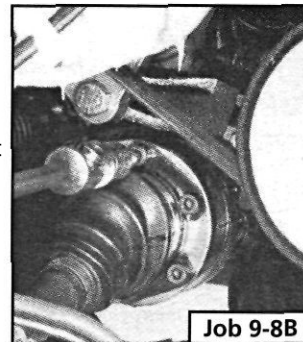

Job 9-8B

• Step 9: Withdraw the shaft from the transmission (illustration Job 9-8A, partb).

• Step 10: Refit in the reverse order, using a new drive-shaft nut tightened to the specified torque. See Chapter 3, Facts and Figures. Stake the nut into the drive shaft groove, as shown.

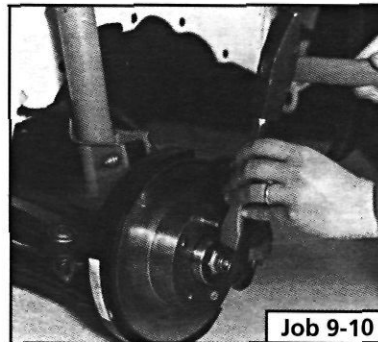

Job 9-10

• Step 11: Refill the transmission with oil. See Chapter 3, Facts and Figures.

Job 10. Drive-shaft (outer) constant velocity joint -

• Step 1: Remove the drive-shaft from the car. See Job 9.

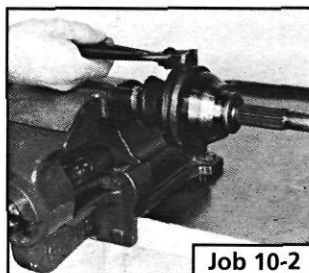

Job 10-2

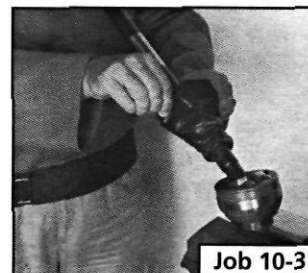

Job 10-3

Q Step 2: Remove the gaiter retaining clip...

Q Step 3: ...and pull the gaiter clear.

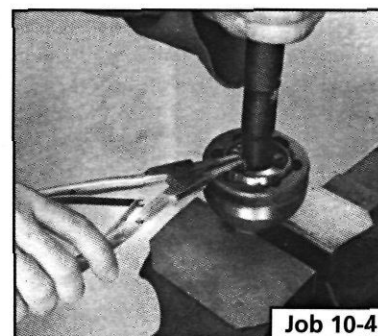

Job 10-4

CJ Step 4: Remove the circlip and pull the CV joint from the shaft.

Q Step 5: Thoroughly clean the joint with petrol or other agent and dry. Check that the balls and their seats are still in a good, unbroken shiny condition - no score marks. Fit a new joint if in doubt.

Q Step 6: Fit the new gaiter onto the shaft, followed by the CV joint and circlip. Pack the joint with the grease supplied or with **FLTutela MRM2** grease.

Q Step 7: Pull the gaiter over the joint and secure with the retaining band or new screw-type clip. The drive-shaft assembly is now ready for refitting.

Job 11. Drive-shaft inner Spicer joint - replacement.

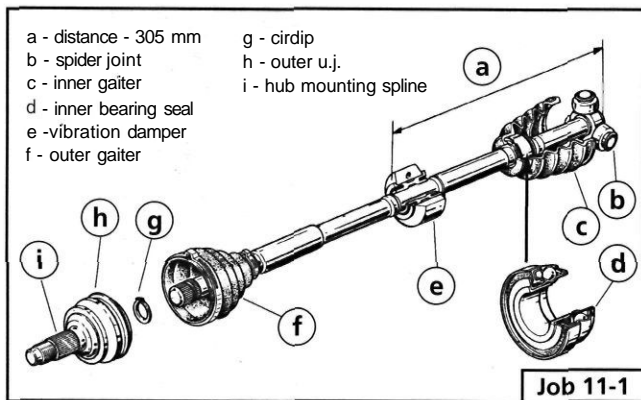

LJ Step 1: Note the arrangement of the inner spider joint and drive-shaft components.

Q Step 2: Remove the drive-shaft from the car. See **Job 9**.

LJ Step 3: Remove the cirdip and pull or press the spider joint from the drive-shaft.



LJ Step 4: Remove the inner gaiter (illustration **Job 11-1, part c**) from the seal bearing (**Job 11-1, part d**). Check the bearing for wear and smooth operation.

LJ Step 5: Replace it if necessary by using a standard type puller to remove it from the shaft, driving the new one into position with a suitable length of tubing.

LJ Step 6: After obtaining a new spider joint, if necessary, (available as a complete replacement item from your FIAT dealership), fit the new gaiter and its retainer to the shaft, followed by the spider joint and cirdip. No lubrication is required prior to refitting the drive-shaft.

• **Step 7: H** **INSIDE INFORMATION!** The turbo diesel uses an inboard CV joint similar to the outer one except that it has a flange for attachment to the transmission. (See **PART A: ENGINE, Job 18, Step 16A.**) Inspect and replace in the same way as the outer one. The intermediate shaft can only be inspected for wear in its bearing which cannot be removed separately. Therefore, the whole unit must be changed if defects are found. **B**

Job 12. Drive-shaft damper - replacement.

Refer to **Job 11, Step 1**.

LJ Step 1: A damper is fitted to the right-hand drive-shaft to prevent vibration in what is a long drive-shaft. The rubber mounting can disintegrate or become damaged.

LJ Step 2: Use an Allen key to separate the two halves of the weight.

LJ Step 3: Replace the (split) rubber mounting and refit the weight.

Job 13. Front hub/bearings - replacement.

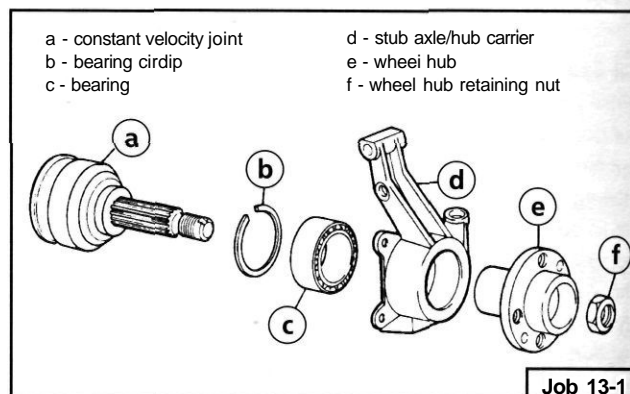

LJ Step 1: Take note of the components illustrated here. Also, see **PART 6; STEERING AND SUSPENSION, Job 12** where this work is described in more detail.

LJ Step 2: Partly dismantle the front suspension as described in **Job 9, Steps 2 to 6**.

LJ Step 3: Unbolt the brake caliper and support bracket and tie it clear.

LJ Step 4: Unbolt the brake disc and shield.

LJ Step 5: Undo the track control arm to stub axle pinch bolt and withdraw the balljoint pin from the stub axle.

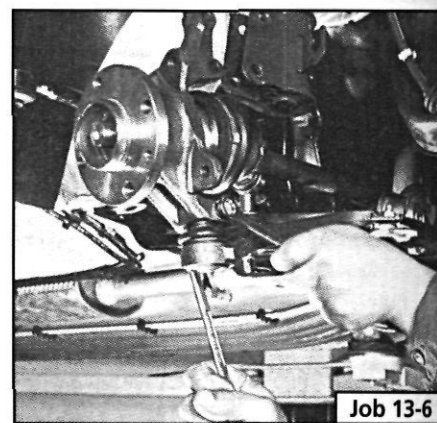

• **Step 6:** Ease the stub axle (illustration **Job 13-1, parts d and c**, combined) off the drive-shaft splines (**Job 11-1, part i**) leaving the inboard end of the drive-shaft still attached to the transmission.

making it easy! • You may find it necessary to pull out gently on the stub axle and at the same time tap lightly (so you don't damage the thread) on the end of the shaft to knock it through.

• Retrieve the stub axle/hub assembly.

LJ Step 7: Use a large vice or a press to push the hub out of the stub axle.

LJ Step 8: You may have to remove the bearing inner track from the hub if it comes out with it.

IJ Step 9:
Remove the bearing retention circlip from the stub axle (also, **Job 13-1, part b**)...

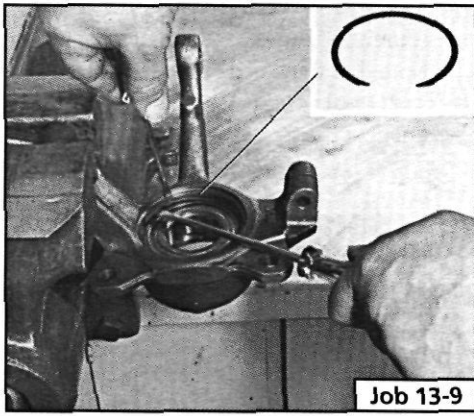

Job 13-9

U Step 10:
...and press out the old bearing (**Hob 13-1, part c**). Note the inner race usually breaks free and has to be drifted off the hub, as shown.



Job 13-10

G Step 11: Clean the stub axle and press in the new bearing, **putting pressure on the outer track only**. Refit the circlip.

U Step 12: Now press the hub into the bearing using a suitable tube putting pressure on the inner track.

Step 13:
Continue the assembly in the reverse order of dismantling and see **Chapter 3, Facts and Figures** for torque settings. Use new drive-shaft to hub nuts and stake them in to the shaft groove. New caliper fixing bolts must also be used.

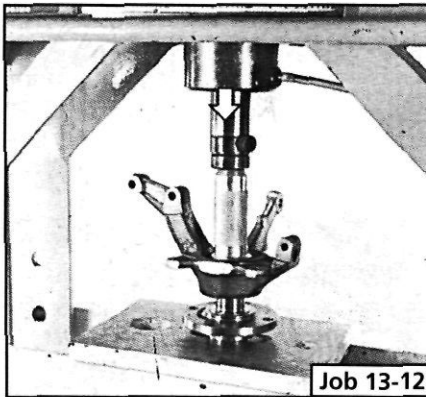

Job 13-12

Job 14. Hydraulic clutch components.

Later Tips and Tempras used a hydraulic clutch in place of the cable arrangement used on the early cars. No adjustment is possible.

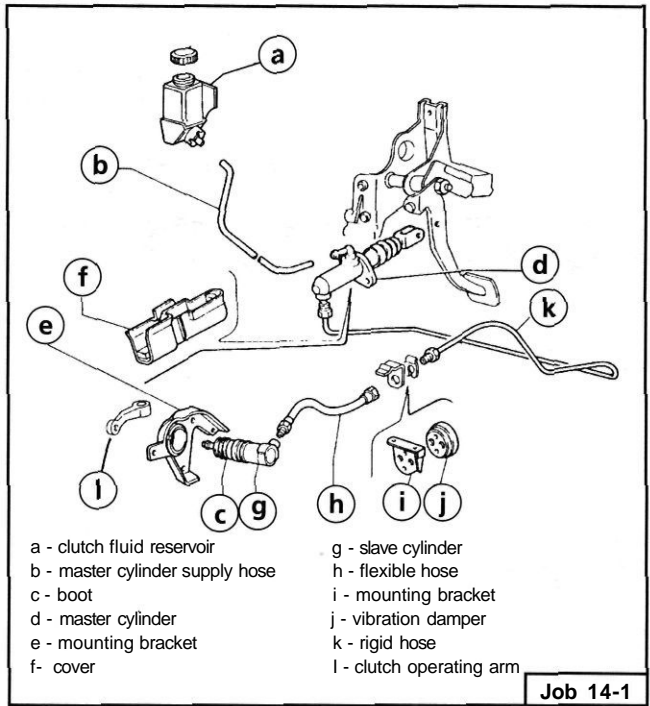

Job 14-1

Q Step 1: This is the layout of the hydraulic clutch components. Note that the master cylinder supply hose (fb) is a low pressure hose. The method of disconnecting the rigid hose (k) and the flexible hose (h) is very similar to that for disconnecting the brake hoses in **PARTH: BRAKES, Jobs 15 and 16**.

Removal of the master cylinder or slave cylinder, should replacement become necessary, can be easily discerned from the drawing shown here. Note that, if the clevis pin which holds the master cylinder to the pedal is worn, it should be replaced. The master cylinder bolts can be reached only after the cover (f) has been undipped and removed. The slave cylinder is held to the gearbox casing by the bracket (e) and must first be disconnected from the clutch arm (l).

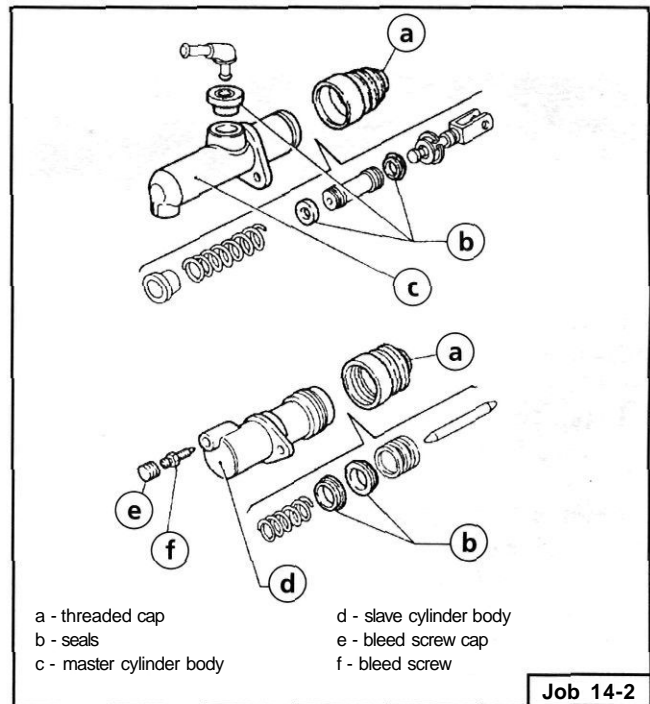

Job 14-2

L Step 2: These are the internal components of the clutch master and slave cylinders. Because the clutch components are not as safely critical as brake components, it is acceptable to

extend their life by fitting new seals, when necessary. Note that you will need to use internal circlip pliers to remove the circlip from the pushrod on the master cylinder in order to dismantle it.

When you need to bleed the clutch hydraulic system, follow the procedure described for brake bleeding in *PARTH*:

BRAKES, Job 17. Because the circuit is far simpler, the procedure itself is likely to be both simpler and quicker to carry out. Note that the bleed screw (f) is normally covered by a cap (e) which must be removed before the bleed screw can be slackened.

PART C: COOLING SYSTEM

PART C: Contents

- | | |
|--|---|
| <p>Job 1: Component positions.</p> <p>Job 2: Radiator and cooling fan - replacement.</p> <p>Job 3: Thermostatic switch - testing and replacing.</p> | <p>Job 4: Thermostat - replacement.</p> <p>Job 5: Coolant pump - replacement.</p> |
|--|---|

Job 1. Component positions.

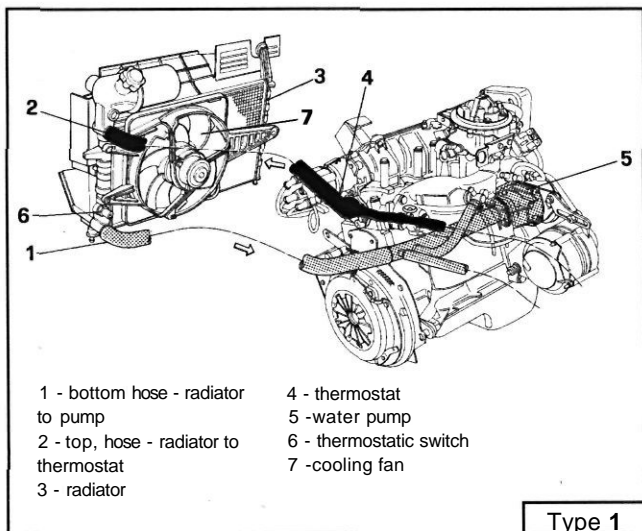

Type 1: These are the components of the petrol engine cooling system...

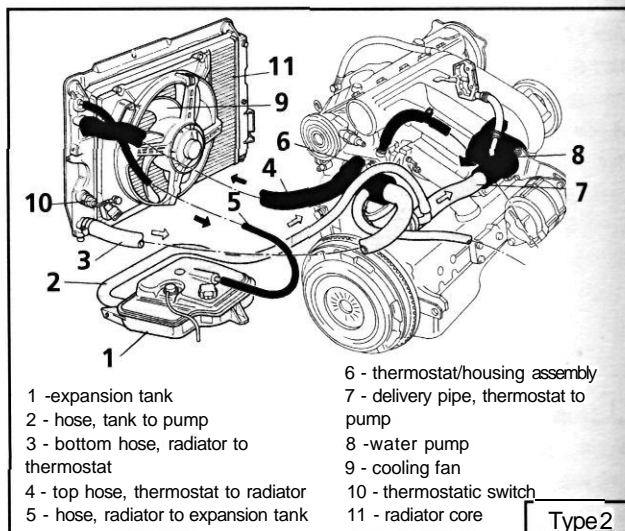

Type 2: ...and these the diesel engine's components.

Job 2. Radiator and cooling fan - replacement.

Q Step 1: Unplug the electrical connections from the fan motor and thermostatic switch.

LJ Step 2: Drain the cooling system and disconnect all hoses from the radiator.

LJ Step 3: Undo the mounting bolts and remove the radiator/fan assembly from the car.

• **Step 4:** Undo the fan mounting fixing bolts and remove the complete assembly from the radiator. Also see illustration *Type 1 (petrol)*, or *Type 2 (diesel)*.

H Step 5: Refit in reverse order.

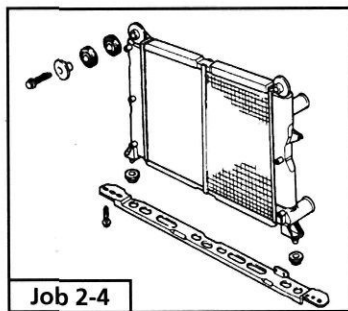

Q INSIDE INFORMATION! The fan assembly can be removed from the car without disturbing the radiator if required. New fan units are supplied by FIAT complete with the mounting bracket, ready to bolt on. **Q**

Job 3. Thermostatic switch - testing and replacing.

Q Step 1: The thermostatic switch which controls the fan is located in the radiator header tank. See illustration *Type 1, part 6 (petrol)*, or *Type 2, part 10 (diesel)*.

Q Step 2: To remove, drain the cooling system, disconnect the switch and unscrew it from the radiator.

• **Step 3:** **Q INSIDE INFORMATION!** Test the switch using a test bulb and two leads. Connect one to a battery terminal and the other to one of the switch terminals. Now connect a wire between the remaining switch and battery terminal. **Q**

J Step 4: Lower the switch into water until the thread is just covered and the terminals remain dry.

U Step 5: Heat the water slowly. The bulb should light just below boiling point (90 to 94 degrees Celsius) and go out when the temperature falls below 85 to 89 degrees Celsius.

U Step 6: Refit with a new O-ring but do not over tighten.

Job 4. Thermostat - replacement.

U Step 1: Drain the cooling system.

U Step 2: Disconnect the hoses from the thermostat housing. Illustration *Type 1, part 4 (petrol)*, or *Type 2, part 6(diesel)*. Undo the bolts and remove the housing/thermostat assembly.

LJ Step 3: Clean the mating surfaces, fit the new unit with a new gasket.

U Step 4: Reconnect the hoses and refill the cooling system with the correct 50/50 FL 'Parafu' anti-freeze mixture. See *Chapter 5, Servicing Your Car*.

Job 5. Coolant pump - replacement.

O INSIDE INFORMATION! For location of the water pump, see illustration *Type 1 (petrol)*, or *Type 2 (diesel)*. D

LJ Step 1: Raise the bonnet and drain the cooling system. Remove the air cleaner.

Q Step 2: Unplug the alternator leads, slacken the bolts and remove the drive belt. Remove the alternator.

LJ Step 3: Disconnect the hoses and the metal transfer pipe from the pump.

LJ Step 4: Undo the securing bolts and remove the coolant pump.

Q Step 5: Discard the old gasket and clean off the mating surfaces.

LJ Step 6: Refit in reverse order using a new gasket.

LJ Step 7: Adjust the drivebelt tension. See *Chapter 5, Servicing Your Car*.

Q Step 8: Fill the cooling system with the correct 50/50 solution of FL 'Parafu' anti-freeze solution. See *Chapter 3, Facts and Figures*.

PART D: IGNITION SYSTEMS

PART D: Contents

Job 1. Ignition component positions.

Job 2. Ignition coil - replacement.

Job 3. Distributor - removal and refitting (1.4 litre engine).

Job 4. Distributor - removal and refitting (1.6 litre engine).

Job 5. Electronic ignition.

Job 1. Ignition component positions.

LJ Point 1: Take note of the positions of the major ignition components.

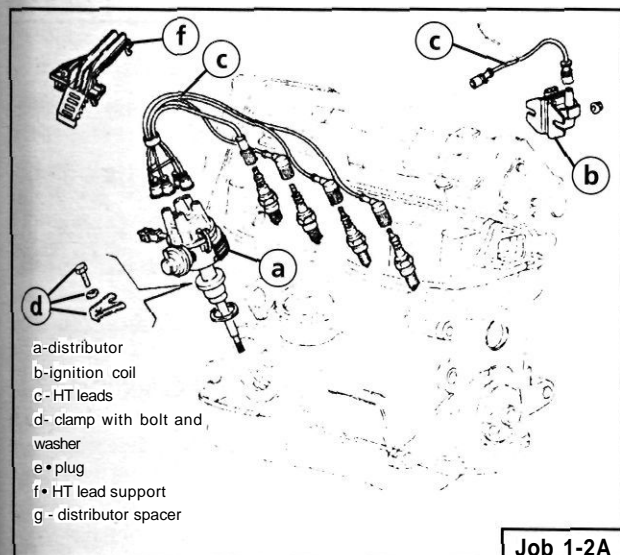

Q Point 2A: This is the 1.4 system, from 1993-on. Earlier components are in the same positions.

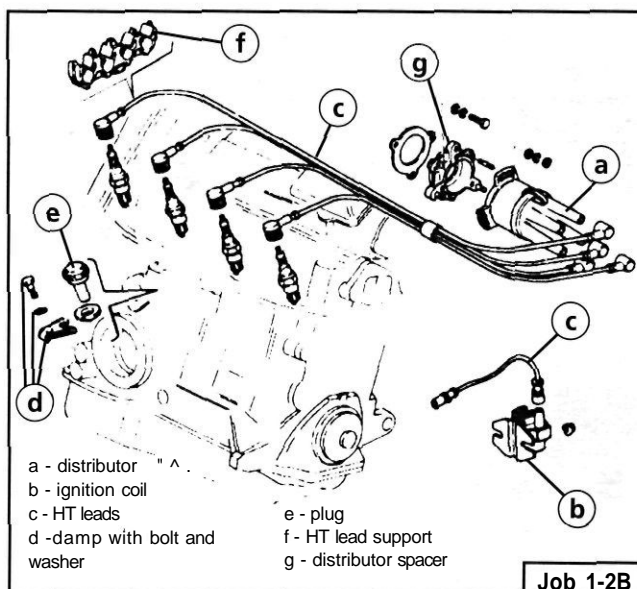

Q Point 2B: These are the 1.6 ignition components. Later models had the coil integral with the distributor.

Job 2. Ignition coil - replacement.

ALL 1.4 MODELS AND 1.6 MODELS UP TO 1993

• **Step 1:** Locate the coil (2) next to the battery.

IMPORTANT NOTE: On 1.6 models from 1993 with SPI Monomotronic fuel injection, the high tension coil is integral with the distributor.

LJ Step 2: Make sure the ignition is switched off and disconnect all LT (the smaller, low tension) wires from the coil, making note of their locations for refitting.

• **Step 3:** Unplug the HT (the thicker, high tension) lead to the distributor at the coil end. Undo the mountings and remove the coil.



Job 2-1

LJ Step 4: Mount the new coil, remake all connections correctly and firmly.

Job 3. Distributor - removal and refitting (1.4 litre engine).

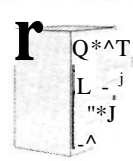

FACT FILE: 1.4 LITRE ENGINE DISTRIBUTOR

This system is of the BREAKERLESS INDUCTIVE DISCHARGE type (2nd generation) and employs a distributor looking much like those used on older cars, still

having an internal centrifugal advance mechanism, a vacuum advance mechanism (3), but NO contact breaker points - an electronic control module (2) instead. This means that once set, the timing cannot alter through points gap fluctuation. Maintenance is also reduced to a minimum, the main requirements being to keep the unit clean and dry.

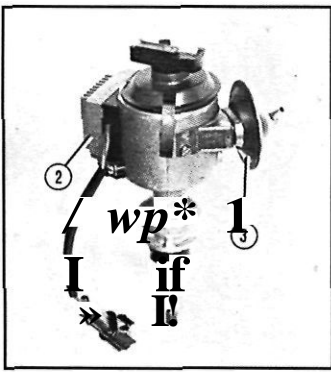

U Step 1: Locate the distributor (see illustration Job 1-2A, part a) which is mounted on the forward facing side of the engine block, close to the timing belt cover.

H Step 2: Remove the distributor cap and leads.

LJ Step 3: Disconnect the (thinner) low tension lead, undo the distributor base clamp and withdraw the distributor.

LJ Step 4: Turn the engine until the crankshaft pulley timing mark is aligned with the '0' (TDC) mark on the timing belt cover (a) and the marks seen through the timing belt window (b), also line up.

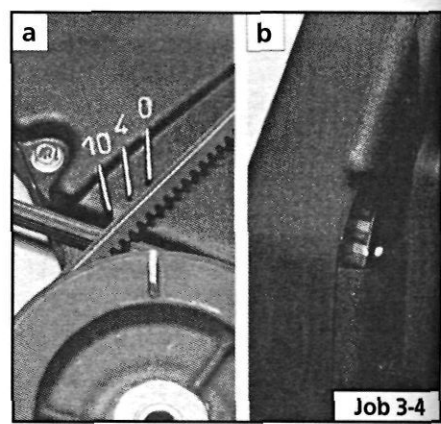

Job 3-4

making it easy! •• **Step 5:** If the marks seen through the window do not align - turn the engine another complete revolution and they will.

LJ Step 6: Refit the distributor with the centre of the rotor contact pointing 180 degrees away from (in other words, exactly opposite) the reference mark on the distributor dust cover.

LJ Step 7: Refit the distributor cap and remake all connections. Leave the vacuum pipe disconnected but plug the end of the pipe.

LJ Step 8: Refit the base clamp but leave just loose enough to allow the distributor to turn.

LJ Step 9: Connect a stroboscopic timing light and start the engine. Run it at between 750 and 850 rpm.

• **Step 10:** Rotate the distributor body the required amount in either direction to align the pulley timing mark with the 10 degree BTDC mark on the timing belt cover and lock the distributor base clamp.

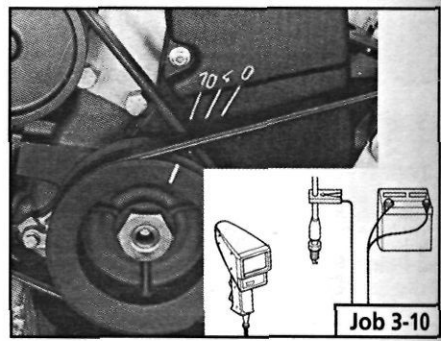

Job 3-10

LJ Step 11: Remove the timing light, unplug and reconnect the vacuum pipe.

Job 4. Distributor - removal and refitting (1.6 litre engine).



FACT FILE: 1.6 LITRE ENGINE DISTRIBUTOR

The DIGIPLEX 2 ALL ELECTRONIC (2nd generation) IGNITION system used on the 1.6 litre engine is of advanced design and requires no maintenance. Because there is no mechanical wear, the advance curves remain constant during the life of the unit. Inaccuracies due to wear or vibration are eliminated. The high spark intensity is constant, even with a low battery when starting, and at high RPM.

PRECAUTIONS • To be taken when working on a car with this system:

- i) • Never attempt to start the car with poor battery connections.
- ii) - Do not use a fast charger to start the engine.
- iii) • Don't disconnect the battery while the engine is running.
- iv) • Before fast charging - disconnect the battery.
- v) - Remove the ECU (electronic control unit) before putting the car in a bodyshop paint oven over 80 degrees Celsius.
- vi) - Make sure the ignition is OFF before plugging in or unplugging the ECU multi-plug.
- vii) - When electric welding - disconnect the battery.

LJ Step 5: Turn the engine so that No. 4 piston is at TDC (compression stroke). See **Chapter 5, Servicing Your Car, Job 25.** Refit the distributor in the reverse order of removal with the nuts just loose enough to allow rotation of the distributor body.

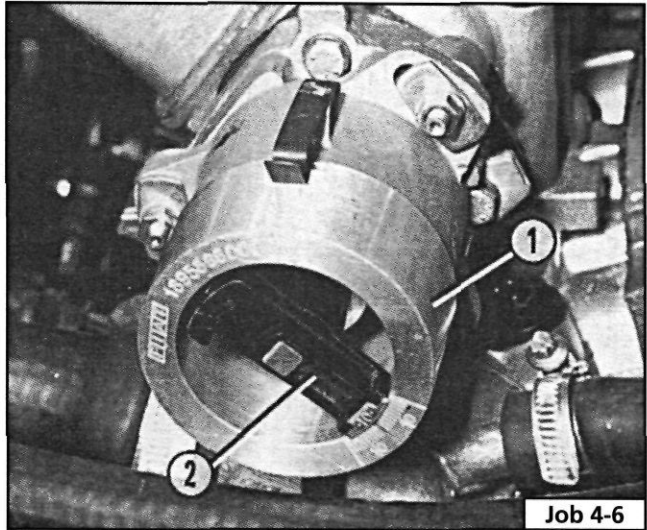

Job 4-6

• **Step 6: Q** **INSIDE INFORMATION!** At this point a FIAT agent would fit tool No.1895896000 (1) to the distributor body and rotate it until the centre of the rotor arm (2) is aligned with the '0' reference mark on the tool. If such a tool is not for hire, exactly align the two halves of the previously scribed mark. This will do the same job providing the distributor was correctly positioned in the first place! Tighten the securing nuts. **D**

J Step 7: Refit the distributor cap and HT leads.

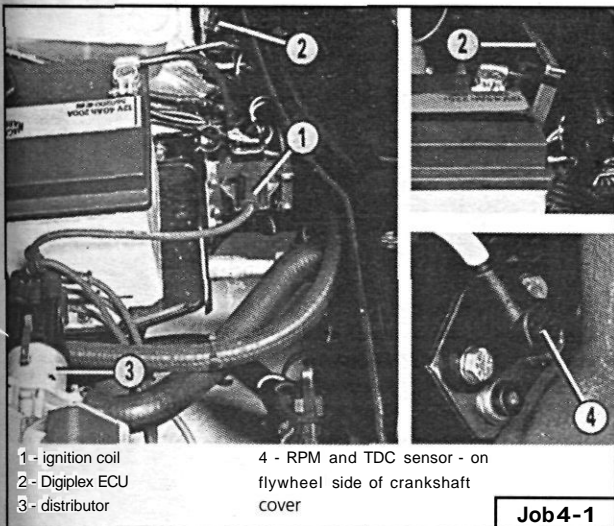

1 - ignition coil
2 - Digiplex ECU
3 - distributor
4 - RPM and TDC sensor - on flywheel side of crankshaft cover

Job 4-1

U Step 1: Take note of the location and identification of the main components:

G Step 2: Before starting to remove the unit, unplug all of the distributor cap HT leads.

Step 3:
Paint a mark across the distributor mounting and spacer lug to retain the exact positioning when refitting. Note the position of the rotor, undo the three distributor securing nuts. Remove the vacuum pipe from the stub (arrowed). Withdraw the distributor.

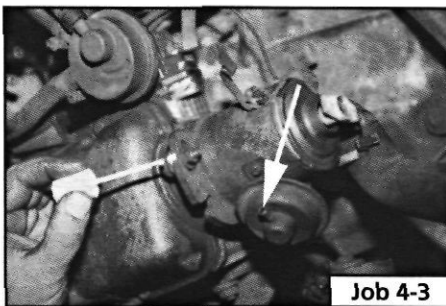

Job 4-3

Step 4: If the mounting spacer is removed, make sure it is refitted with the recess (arrowed) facing downwards.

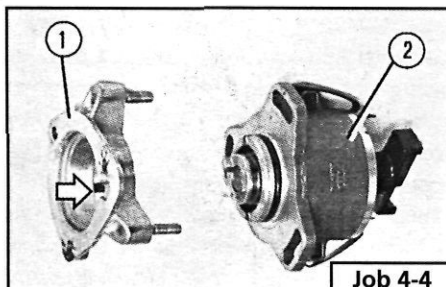

Job 4-4

Step 8: FACT FILE: TOP DEAD CENTRE/RPM SENSOR



The TDC and RPM sensor (illustration **Job 4-1, part 4**) is correctly positioned during production and its (adjustable) mounting plate should not be moved. (In fact, the sensor can be removed from and refitted to the mounting plate - only the latter is adjustable.) To prevent the plate from being moved accidentally, one of the bolts holding the mounting plate to the engine is of the 'shear' type and has no flats. If there is a need to adjust the sensor mounting plate, special FIAT tool 1895898000 is required and this then becomes a job for your FIAT dealer, who will also replace the shear bolt.

Job 5. Electronic ignition.

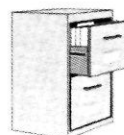

FACT FILE: BREAKERLESS INDUCTIVE DISCHARGE AND DIGIPLEX 2 ALL ELECTRONIC IGNITION SYSTEMS

Unfortunately, it is not possible to check either of the two systems described in this manual without the use of the correct FIAT diagnostic equipment. If your engine is malfunctioning and you suspect the ignition, ask your FIAT agent to check it.

AIR CONDITIONING (EARLY MODELS)

Air conditioning is an optional extra fitted to some models of Tipo and Tempra.

AIR CONDITIONING SWITCH

5D. When you turn on the air conditioning it will initially operate at the first fan speed even if set at position 0.

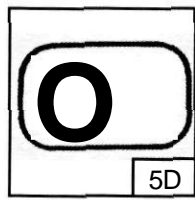

AIR RECIRCULATION SWITCH

5E. When pressed, no outside air enters the passenger compartment. Use the recirculation feature for fast cooling or heating. Select recirculation whenever you drive in heavy traffic, in a tunnel or under any conditions where the air is heavily polluted.

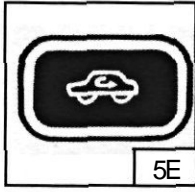

Use the following settings for maximum cooling:

- Turn the air temperature adjustment knob to the blue zone.
- Turn the air conditioner switch ON.
- Turn the air volume control knob to position MM
- Turn the air distribution control knob to 5.

AIR CONDITIONER HEATING

Turning the air temperature adjustment knob to the red zone:

- Turn the air volume control knob to the desired fan speed.
- Turn the air distribution control knob (illustration 5Q to 2 cold, sunny weather or 3 heating.

IMPORTANT NOTE: The air conditioner and heater may be used at the same time during winter or whenever the weather is particularly humid, for optimal demisting .

DEFROSTING THE WINDSCREEN AND WINDOWS

- Turn the air temperature adjustment knob (illustration 5B) to the red zone.
- Select fan speed 3 or 4.
- Turn the air distribution control knob to 4.
- Press the air conditioner switch for efficient demisting.

VENTILATION

- Turn the air temperature control knob (illustration 5B) to the blue zone.
- Select the fan speed desired.
- Turn the air distribution control knob (illustration 5Q to position 5.

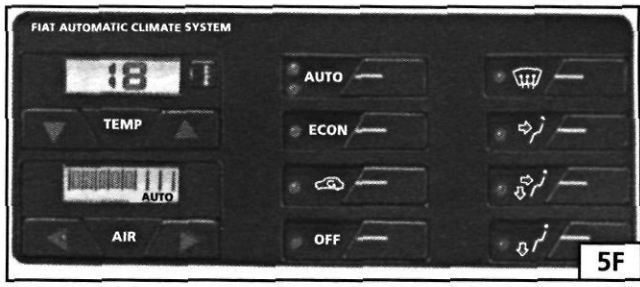

AIR CONDITIONING (LATER MODELS)

5F. The air conditioning controls fitted as an optional extra to some later models of Tipo or Tempra are shown in illustration 5F.

TEMPERATURE CONTROL

- Use the TEMP button to select the cabin temperature.
- Each time the TEMP button (up or down arrow) is pressed the temperature will increase or decrease by 1°C.
- If the temperature displayed exceeds 32°C or is lower than 18°C the words HI or LO will appear on the display.
- When the ECON button is selected the temperature will remain static until the outside temperature drops sharply or until the ECON button is switched off.

AIR VOLUME CONTROL

- Press the AIR left or right arrow buttons to increase or decrease the air flow into the passenger compartment.

AIR DISTRIBUTION CONTROL

- 5G. • Press the demisting button 1 to demist the windscreen and side windows.
- Select button 2 to direct the air flow to the passenger face vents.
 - Press button 3 to direct the air flow towards the footwell and face vents.
 - Selecting button 4 will direct the air flow to the floor vents.

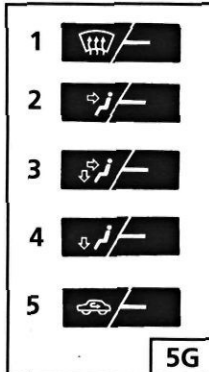

AIR RECIRCULATION SWITCH

- When the air recirculation button (illustration 5G, 5) is selected no outside air enters the passenger compartment.

AUTOMATIC OPERATION

- When both LEDs next to the AUTO button light up, the system is fully automatic.
- When only one LED lights up the system is in manual operation.
- When the OFF button is pressed the LED next to it will light up and all of the systems other LEDs will turn off, indicating that the air control system has been switched off.

PART E: ELECTRICAL AND INSTRUMENTS

PART E: Contents

Job 1. Alternator - removal and refitting.
 Job 2. Starter motor - removal and refitting.
 Job 3. Instrument panel - removal and refitting.
 Job 4. Speedometer cable - replacement.
 Job 5. Windscreen wiper motor - replacement.
 Job 6. Hatchback wiper motor - replacement.
 Job 7. Windscreen washer pump - replacement.
 Job 8. Radio aerial - replacement.
 Job 9. Headlight cluster - replacement.

Job 10. Rear light cluster - replacement.
 Job 11. Side repeater indicators - replacement.
 Job 12. Number plate light - replacement.
 Job 13. interior/courtesy light - removal and refitting.
 Job 14. Fuel gauge sender unit - removal and refitting.
 Job 15. Central locking - replacement of components.
 Job 16. Electric windows - replacement of components.
 Job 17. Diesel engines. Glow plugs - checking and replacement.

Job 1. Alternator - removal and refitting.

Q Step 1: Disconnect the battery earth lead.

UI Step 2: Disconnect all the wires from the back of the alternator - the main output wire is released by undoing its securing nut. Slacken the bolt securing the inboard end of the adjustment bar, undo and remove the bolt from the alternator end of the bar. Slacken the drivebelt and remove it.

Q Step 3: On manual steering cars, unbolt and remove the adjuster bracket from the cylinder block.

Q Step 4: Release the securing buttons and remove the engine splash shield on power steering cars.

d Step 5: Undo the nut from the long through bolt and note the position of the washers. Support the alternator and remove the bolt, then withdraw the alternator from the car.

LJ Step 6: Refit in reverse order and make sure your electrical connections are sound. Adjust the drivebelt tension. See *Chapter 5, Servicing Your Car*.

Job 2. Starter motor - removal and refitting.

Q Step 1: Disconnect the battery earth lead.

• Step 2: Undo and remove all the electrical connections (a) from the starter (b) and starter solenoid (c).

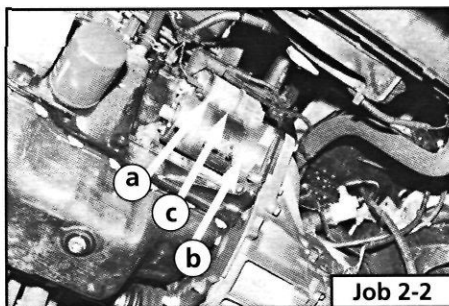

Job 2-2

• Step 3: Undo the three mounting bolts and the wiring harness bracket from the top bolt and withdraw the starter.

Q Step 4: Refit in reverse order, ensuring that all connections are sound.

Job 3. Instrument panel - removal and refitting.

Q Step 1: Disconnect the battery at the negative (earth) terminal.

• Step 2: Undo the screws (arrowed) and remove the speaker cover (1).

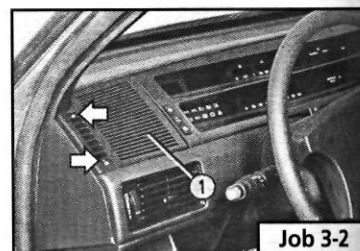

Job 3-2

• Step 3: Undo the exposed screws that secure the instrument panel (arrowed).

• Step 4: Slide off the screw cover (2) from the other end of the instrument panel and remove the two screws found beneath it.

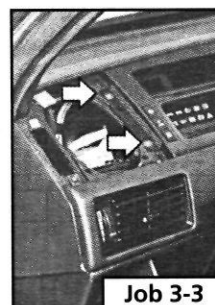

Job 3-3

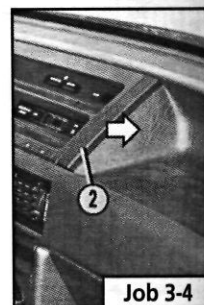

Job 3-4

C Step 5: Raise the instrument panel enough to unplug the connectors from the rear. Disconnect the speedometer drive (if non-electronic type) and remove the instrument panel from the car.

d Step 6: Refit in the reverse order and be sure that all connections are properly made.

Job 4. Speedometer cable - replacement.

• Step 1: O INSIDE INFORMATION! The cable comes in two parts, joined in the middle by a connector (a). Q

• Step 2: Follow *Job 3, Steps 1 to 3*. Then, lift the instrument panel sufficiently so that you can gain access to the cable.

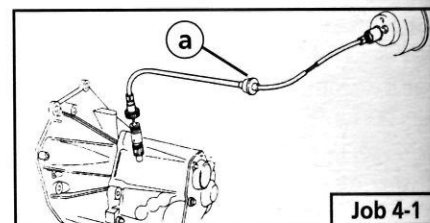

Job 4-1

LJ Step 3: Disconnect the drive cable from the back of speedometer.

U Step 4: From under the bonnet, uncouple the two cable halves from the centre connector and withdraw the speedometer section through the bulkhead.

Q Step 5: Disconnect the lower end of the cable from the gearbox drive and remove it.

LJ Step 6: Follow the reverse procedure to refit the cable, being careful to run the cable as straight as possible, avoiding sharp bends.

Job 5. Windscreen wiper motor - replacement.

U Step 1: Disconnect the battery negative (earth) terminal.

G Step 2: Note the position of the wiper blades on the screen. Remove the two windscreen wiper arms and then the grille cover.

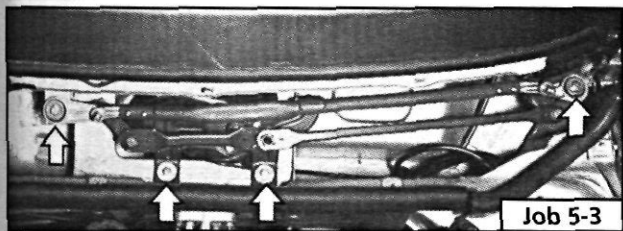

Job 5-3

U Step 3: Unplug the electrical connector and undo the four mounting screws (arrowed). Remove the complete assembly.

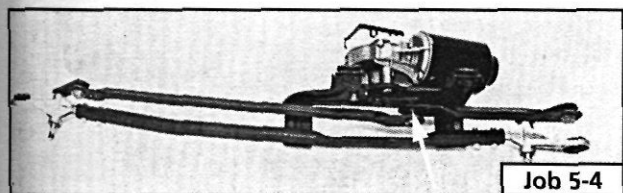

Job 5-4

Q Step 4: Uncouple the linkage rods from the motor (arrowed).

U Step 5: Remove the motor by undoing the three mounting bolts.

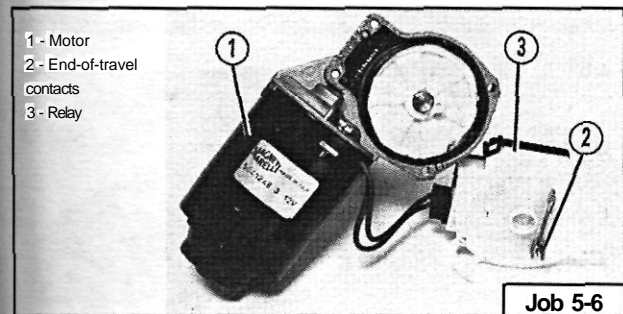

Job 5-6

Q Step 6: Note the location of - and wiring for - these components.

U Step 7: Refitting is the reverse of removal, but take care to position the wiper arms as you found them after first making sure the motor is 'parked'.

Job 6. Hatchback wiper motor - replacement.

IMPORTANT NOTE: For a view of the headlight wiper motor (where fitted) refer to **Job 7, Step 3**.

PART A: TIPO MODELS

• Step A1: This is a view of the components for the Tipo rear wiper.

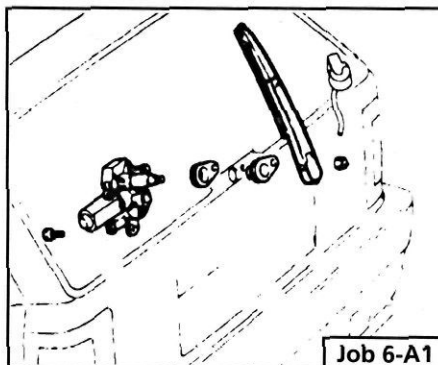

Job 6-A1

• Step A2: Undo the securing nut and remove the wiper arm.

H Step A3: Open the tailgate and pull the weather strip away from the top of the interior trim panel.

LJ Step A4: Remove the five screws holding the trim in place - three of these also secure the lock.

LJ Step A5: Carefully lever out the trim fixing clips freeing the trim. Unplug the wiring to the tailgate lock motor (if fitted) and remove the lock/trim panel assembly.

LJ Step A6: Unplug the wires from the wiper motor, undo the three screws holding the motor in place and remove the motor assembly.

LJ Step A7: Check that the seal in the tailgate wiper shaft hole is in good condition and then start refitting in reverse order. Make sure the wiper motor is 'parked' before fitting the arm and blade.

PART B: TEMPRA MODELS

LJ Step B1: This shows the layout of the Tempra rear wiper.

Lj Step B2: Disconnect the battery earth lead. Undo the securing nut and remove the wiper arm.

LJ Step B3: Remove the motor cover shield.

LJ Step B4: Disconnect the wiring plug and washer tubing.

LJ Step B5: From outside, undo and remove the wiper shaft nut and retrieve the spacer/seal.

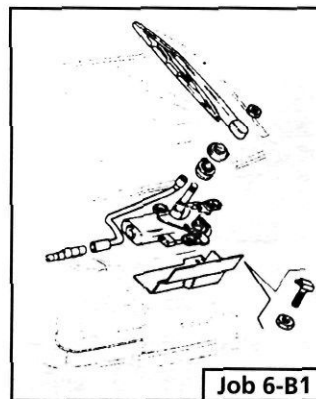

Job 6-B1

U Step B6: From inside, undo the mounting bolts and remove the motor.

LJ Step B7: Refit in reverse order.

Job 7. Windscreen washer pump - replacement.

LJ Step 1: Disconnect the battery earth terminal.

• **Step 2:** Locate the pump (arrowed), which is a push fit in the washer fluid reservoir and disconnect the electrical plug.

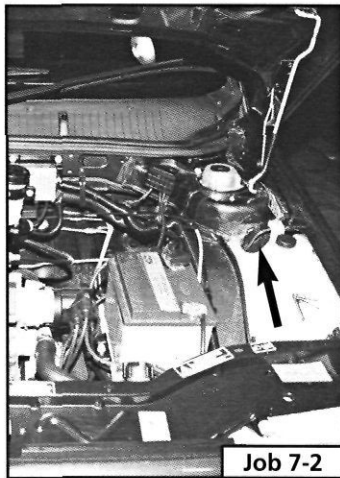

• **Step 3:** Withdraw the pump and disconnect the tubing. This, for reference, is the layout of the headlight washer pipes and the headlight wiper motor.

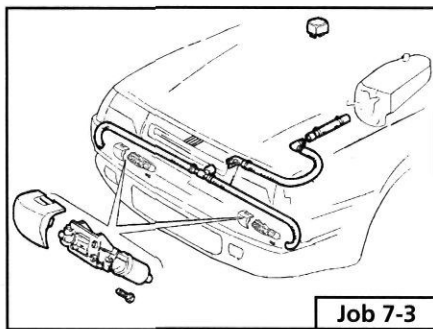

LJ Step 4: Check the condition of the seal before refitting in reverse order.

Job 8. Radio aerial - replacement.

LJ Step 1: Refer to Job 13 and remove the interior light.

Step 2: Now disconnect the aerial lead from the exposed base and undo the securing nut.

LJ Step 3: Remove the aerial from outside the car.

G Step 4: Reverse the process to refit but ensure that the seal is good between the aerial and the roof to prevent water ingress.

Job 9. Headlight cluster - replacement.

• **Step 1:** Remove the radiator grille - see **PART I: BODY AND INTERIOR**

• **Step 2:** Disconnect the battery. Unplug all the wires serving the light cluster. Undo the fixing bolts (arrowed)...

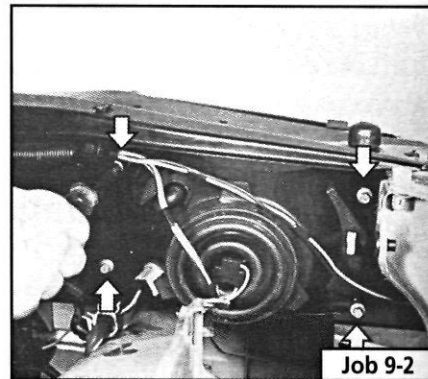

U Step 3: ...and withdraw the complete assembly.

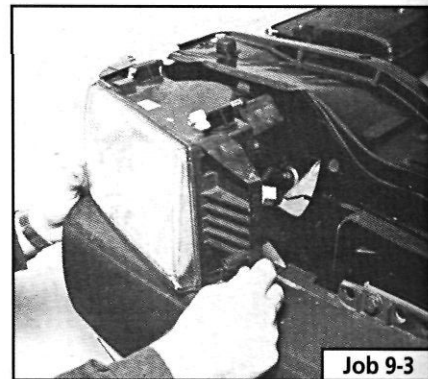

• **Step 4:** Refit in the reverse way and have the beam alignment checked by your local FIAT service agent.

Job 10. Rear light cluster - replacement.

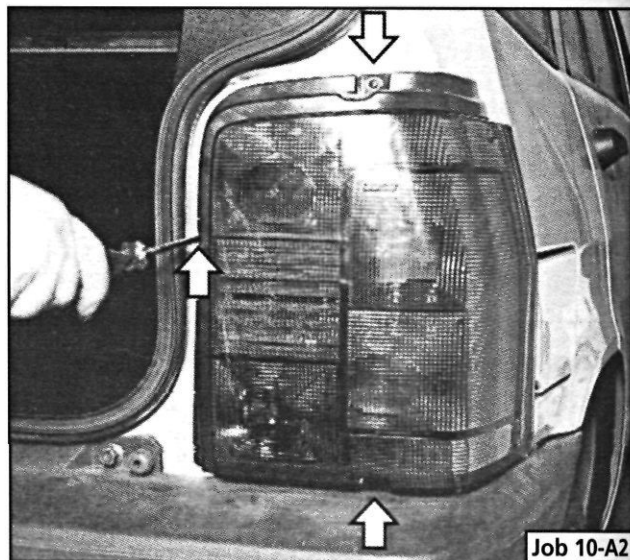

PART A: TIPO MODELS

LJ Step A1: Disconnect the battery.

• **Step A2:** Raise the tailgate and undo the fixing screws (arrowed).

• **Step A3:** Withdraw the cluster and disconnect the wiring plug.



LJ Step A4:

Undo the two screws to detach the printed circuit/bulb holder (2) from the cluster (1).

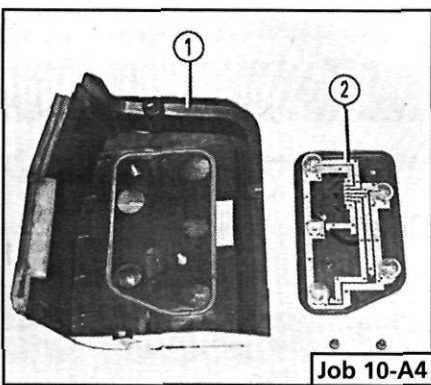

G Step A5:

Reverse these operations to refit.

Job 10-A4

PART B: TEMPRA MODELS

G Step B1: Disconnect the battery earth lead.

LJ Step B2: Undo the screw at the top and remove the lens.

G Step B3: SALOON MODELS.

This is the layout of the components. See Step B4.

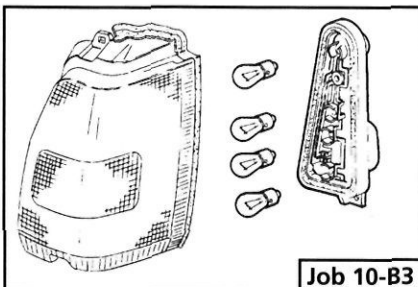

Job 10-B3

G Step B4: ESTATE MODELS.

Unplug the wiring connector. Undo the three screws (positions arrowed) and withdraw the light cluster.

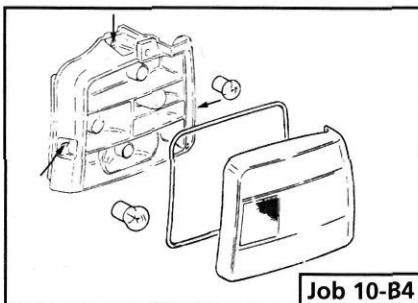

Job 10-B4

G Step B5: Refit in reverse order.

Job 11. Side repeater indicators - replacement.

G Step 1: Remove the protective cover from under the wing to gain access to the back of the light unit.

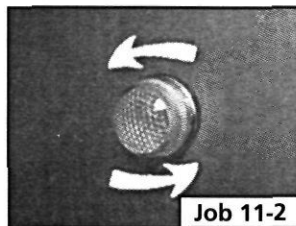

Job 11-2

G Step 2: Twist and remove the light lens.

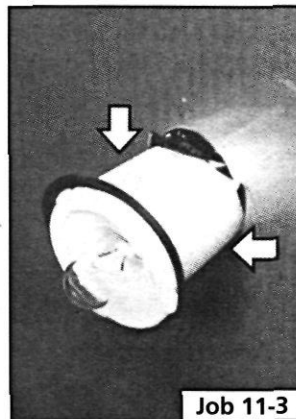

Job 11-3

G Step 3: Release the two retaining clips on the light unit body (arrowed). Withdraw the light unit and unplug the connector.

G Step 4: Refit in reverse order.

Job 12. Number plate light - replacement.

PART A: TIPO MODELS

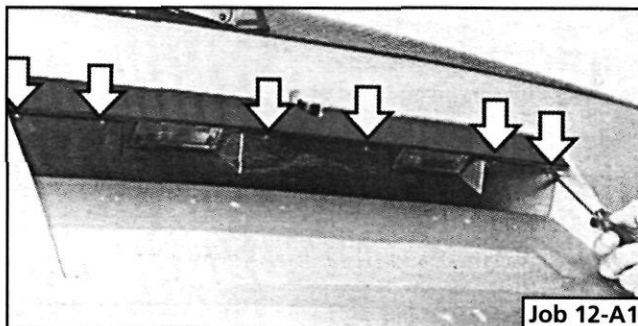

Job 12-A1

LJ Step A1: Undo the six fixing screws (arrowed)...

• Step A2: ...and withdraw the unit.

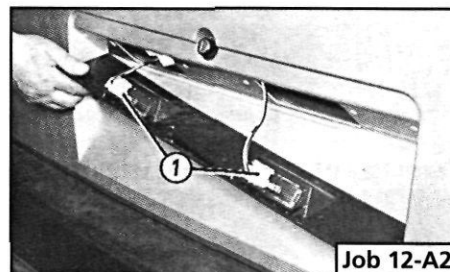

Job 12-A2

LJ Step A3: Unplug the wires from the bulb holders (1) and the unit becomes free.

PART B: TEMPRA MODELS

LJ Step B1: Release the number plate light securing clips and withdraw the lights.

LJ Step B2: Disconnect the wiring plug and remove the lights.

LJ Step B3: Refit in reverse order.

Job 13. Interior/courtesy light - removal and refitting.

LJ Step 1: Remove the battery earth lead. Use a screwdriver and carefully prise off the interior light lens.

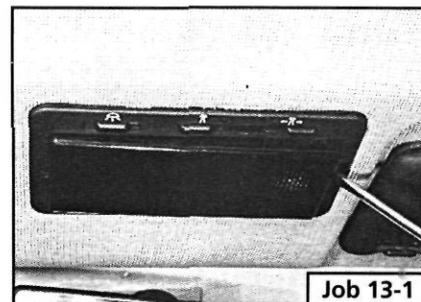

Job 13-1

• Step 2: Release the press clips, two on each end (arrowed) unplug the connector and withdraw the light.

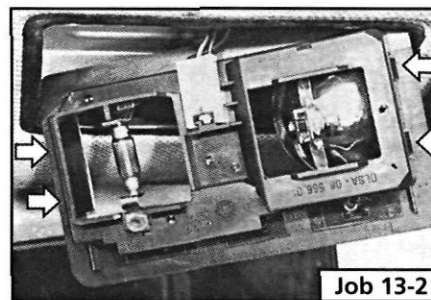

Job 13-2

IMPORTANT NOTE: Some types are held in place with screws, found beneath the

courtesy light lens and/or panel. The connectors are on the rear of the unit.

LJ Step 3: The estate car has a rear courtesy light which is removed as in **Step 1** and **2**.

J Step 4: Refit in the reverse order.

Job 14. Fuel gauge sender unit - removal and refitting.

SAFETY FIRST!

- Carry out this work out of doors, away from sources of ignition.
- Make the open aperture on top of the fuel tank air tight as quickly as possible.
- You should carry out this job when the fuel is at a low level.

VEHICLES WITH ELECTRIC FUEL PUMPS (NOT ENGINE MOUNTED)

J Step 1: Disconnect the battery earth lead.

LI Step 2: Lift the luggage compartment floor covering and prise the round plastic cover from the floor to expose the sender unit.

G Step 3: Unplug the sender unit wires and position them out of the way.

GJ Step 4: Using the two opposing lugs on the unit, (FIAT tool no. 1854045000 or similar would be useful) twist it in an anti-clockwise direction and remove it from the fuel pipe housing.

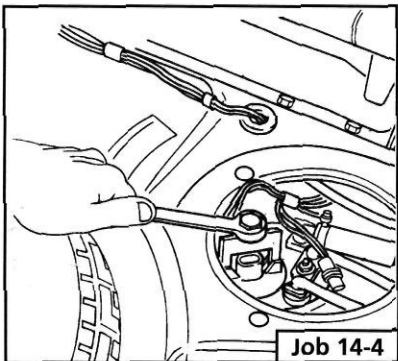

Job 14-4

Q Step 5: Check the condition of the sealing ring and replace it if necessary.

U Step 6: Refit in the reverse order.

VEHICLES WITH ENGINE MOUNTED FUEL PUMPS

Step 7: Where a mechanical fuel pump is fitted, the sender unit looks like this. A ring nut is used to secure it to the top of the fuel tank.

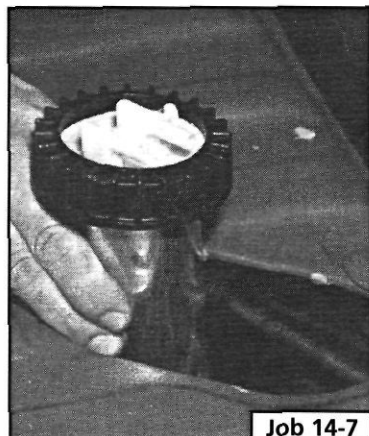

Job 14-7

Job 15. Central locking - replacement of components.

PART A: ELECTRONIC CONTROL UNIT

Q Step A1: Disconnect the battery at the earth terminal.

Step A2: The electronic control unit (1) is mounted directly on the junction unit to the left of the foot pedals. To change it, simply unplug it and plug the new one in.

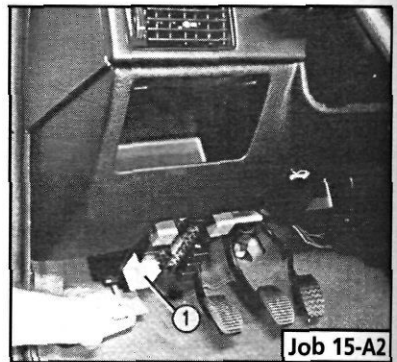

Job 15-A2

J Step A3: Reconnect the battery.

PART B: DOOR LOCK SWITCHES AND MOTORS

Q Step B1: Both door lock switches and motors are an integral part of the lock assembly. Therefore, if a fault develops in either, the complete unit will have to be changed. See **PART I: BODYWORK AND INTERIOR**.

Job 16. Electric windows - replacement of components.

PART A: ELECTRONIC CONTROL UNIT

Step A1: You will find the electronic control unit (1) mounted beside the junction unit...

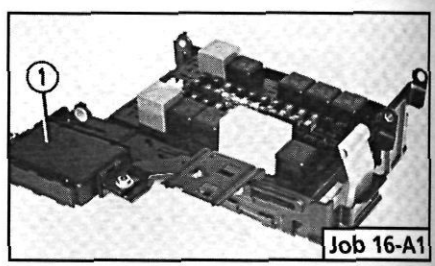

Job 16-A1

Step A2: ...while the circuit fuse (2) is on the junction unit holder. First, disconnect the battery earth lead.

d Step A3: Disconnect the electrical plugs, undo the securing screws and withdraw the unit.

Step A4: Refit in reverse order.

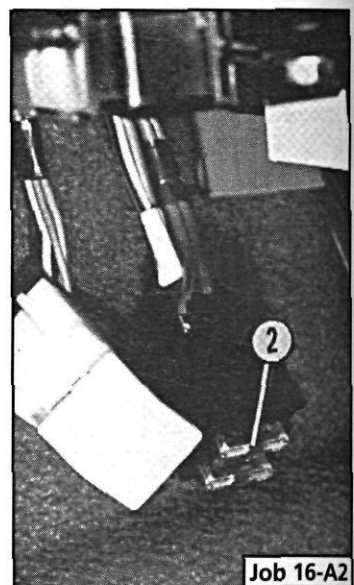

Job 16-A2

PART B: WINDOW CONTROLS

U Step B1: Disconnect the battery earth terminal.

LJ Step B2: Undo the screw and remove the armrest trim, then undo the screws fixing the armrest and withdraw it enough to unplug the wiring. See **PART I: BODYWORK AND INTERIOR**.

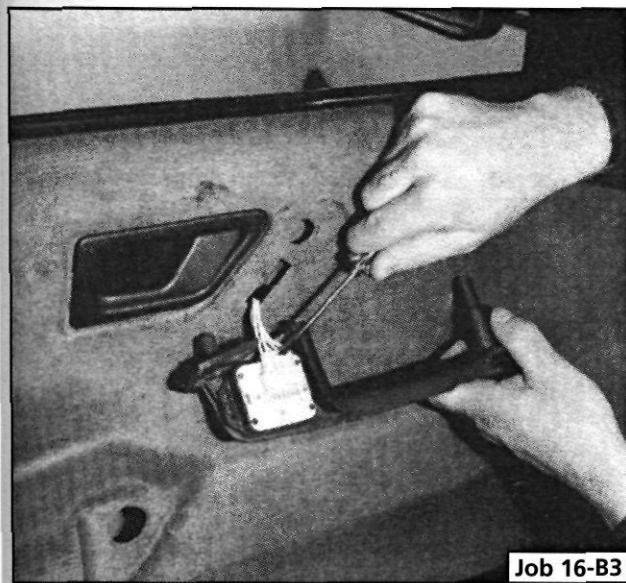

LJ Step B3: From inside the armrest, undo the retaining screws and detach the control panel from the armrest.

Q Step B4: Refit in the reverse order.

PART C: COURTESY LIGHT/WINDOW LIFT INTERLOCK SWITCHES

LJ Step C1: Disconnect the battery earth lead.

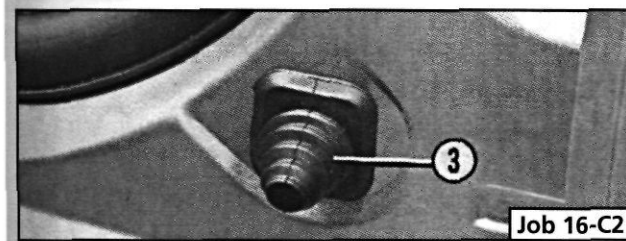

Q Step C2: Take off the rubber dust cover (3), prise the switch out of the panel and disconnect the wire.

Q Step C3: Refit in reverse order.

PART D: WINDOW OPERATING MOTOR

Q Step D1: The motors are an integral part of the winding mechanism and therefore can only be changed as a complete assembly. Refer to **PART I: BODYWORK AND INTERIOR**.

Job 17. Diesel engines - Glow plugs, checking and replacement.

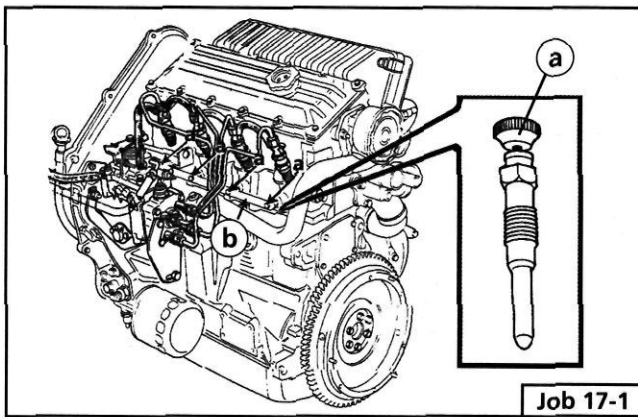

LJ Step 1: Disconnect the battery earth lead. Undo the retaining nut at each plug top (a) and remove the bridging strip (b) from between the glow plugs (complete glow plug - inset).

• Step 2: With the wire or connecting strap removed, unscrew each plug from the cylinder head by just a couple of turns using a ring spanner (as shown) or socket.

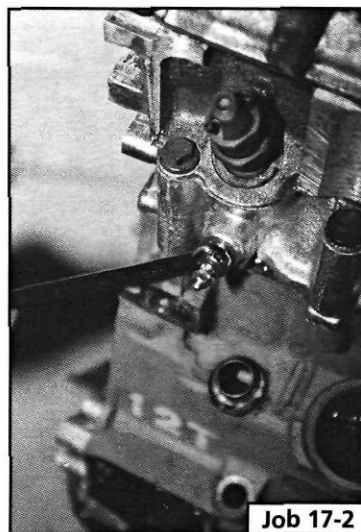

LJ Step 3: Clean away dirt from around the plugs, then fully unscrew and remove them. It's a good idea to blank off the plug hole with cloth to prevent dirt from entering.

Q Step 4: Examine the condition of each plug by wiping soot away and examining for erosion of the element sheath.

Q Step 5: Check the internal resistance of each glow plug by connecting across a resistance meter. You are looking for a resistance of 5 ohms or less. If the reading is much higher than this, or is infinity, the plug must be renewed.

Q INSIDE INFORMATION: It is false economy to **renew** only one glow plug at a time - we recommend a complete set of new plugs if any one plug is in poor condition. **Q**

Q Step 6: Refit the glow plugs and tighten to their specified torque - see **Chapter 3, Facts and Figures**. Over tightening a glow plug can damage it!

• Step 7: Refit the bridging strip and connect the supply lead.

PART F: FUEL AND EXHAUST SYSTEMS

PART F: Contents

- Job 1.** Fuel system types.
- Job 2.** Carburettor - removal and refitting.
- Job 3.** Petrol injection unit - removal and refitting.
- Job 4.** Accelerator cable, carburettor engines - replacement and adjustment.
- Job 5.** Carburettor choke cable - replacement and adjustment.
- Job 6.** Accelerator cable, petrol injection engines - replacement and adjustment.
- Job 7.** Diesel engines. Accelerator cable - replacement and adjustment.
- Job 8.** Mechanical fuel pump, petrol engine (carburettored) - replacement.

- Job 9.** Electric fuel pump, petrol engine (S.P.t.) - replacement.
- Job 10.** Fuel tank - removal and refitting.
- Job 11.** Hot air hoses/thermo-valves - general.
- Job 12.** Lambda sensor (S.P.I, engines) - replacement.
- Job 13.** Fuel evaporation system.
- Job 14.** Exhaust system - replacement.
- Job 15.** Turbocharger, diesel engine - replacement.
- Job 16.** Diesel injection pump - removal and refitting.
- Job 17.** Diesel injectors - remove and refit.
- Job 18.** Bleeding Diesel fuel system.



FACT FILE: FUEL INJECTION/ELECTRONIC IGNITION PRECAUTIONS

OBSERVE THE FOLLOWING PRECAUTIONS WHEN WORKING ON PETROL-ENGINED

VEHICLES WITH FUEL INJECTION - ELECTRONIC IGNITION SYSTEMS:

- never start the engine when the electrical terminals are poorly connected or loose on the battery poles;
- never use a quick battery charger to start the engine;
- never disconnect the battery from the car circuit with the engine running;
- when charging the battery quickly, first disconnect the battery from the vehicle circuit;
- if the vehicle is placed in a bodyshop drying oven after painting at a temperature of more than 80 degrees Celsius, first remove the injection/ignition ECU;
- never connect or disconnect the ECU multiple connector with the ignition key in MARCIA position;
- always disconnect battery negative lead before carrying out electrical welding on vehicle.

Note that some systems contain one memory that is always active (stand-by memory) and that stores learnt self-adaptive values. Because this data is lost when the battery is disconnected, this operation should be carried out as infrequently as possible.

Job 1. Fuel system types.

Refer to illustrations in **Job 1** for typical layouts.

It's a good idea to familiarise yourself with the type of fuel system fitted to your car. These are the main types.

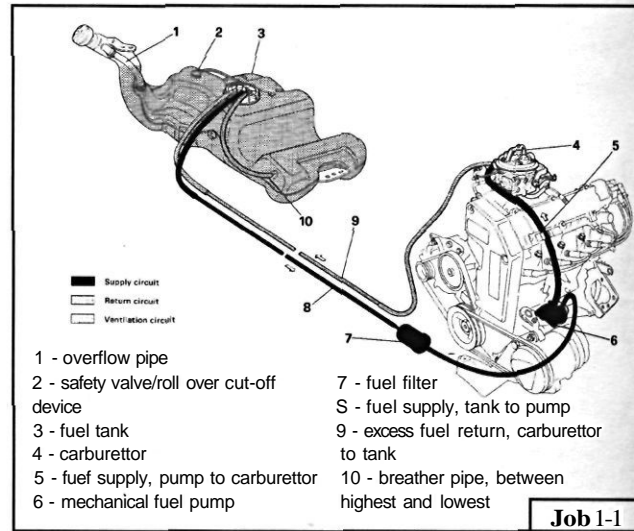

Job 1-1

LJ Type 1: This is the 1400/1600cc carburettored engines fuel system.

SAFETY FIRST!

- *The high pressure pipework on a petrol or diesel fuel injection system can retain its pressure for days even after the engine has been switched off.*
- *When you disconnect the pipework, a jet of fuel can be emitted under very high pressure - strong enough to penetrate the skin or damage the eyes.*
- *NEVER work on the fuel pipework when the engine is running (except when bleeding Diesel injectors - see Job 18.*
- *ALWAYS place a rag over a union while it is being undone until all the pressure has been let out of the system.*

- *You must wear strong rubber gloves and goggles when disconnecting the fuel injection system's high pressure pipework. Always disconnect VERY slowly, letting pressure out progressively.*
- *See Job 8 for details of how to depressurise the system.*
- *Disconnect the battery negative earth before working on the fuel system.*
- *Work outdoors and away from sources of flame or ignition.*
- *ALWAYS wear rubber gloves - don't let your skin come into contact with fuel.*

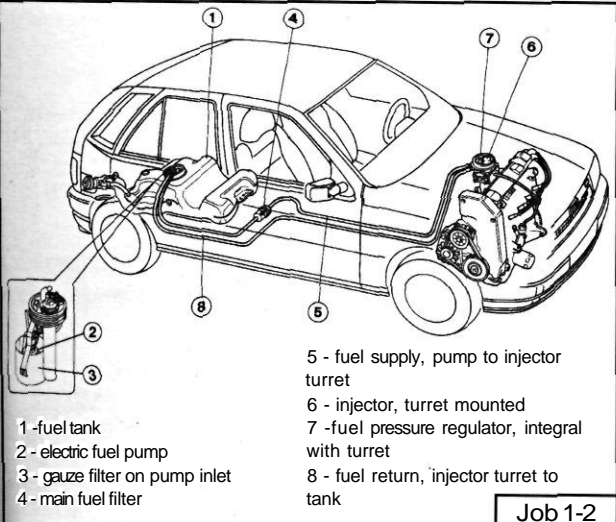

Q Type 2: This is the fuel supply circuit for the 1400/1600cc engines using the Bosch Mono-Jetronic S.P.I. System and Bosch Monomotronic injection systems (1400cc type shown).

D INSIDE INFORMATION! The main fuel filter (4) is protected by a rubberised shield which must be lowered at one end for access. **Q**

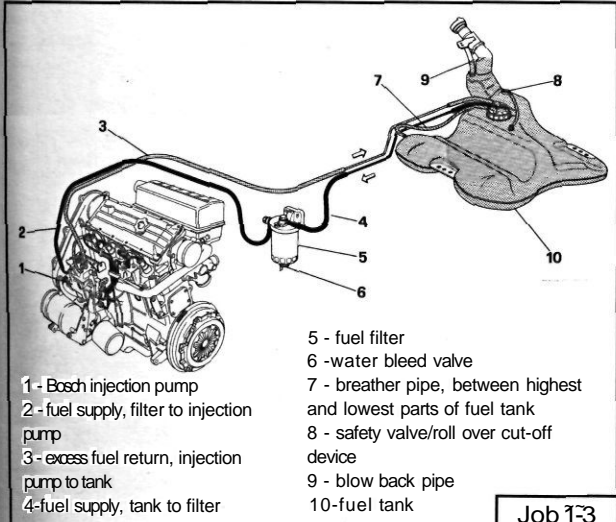

Q Type 3: This is the fuel supply system for the 1700 and 1900cc Diesel engines, (<1700cc shown).

Job 2. Carburettor - removal and refitting.

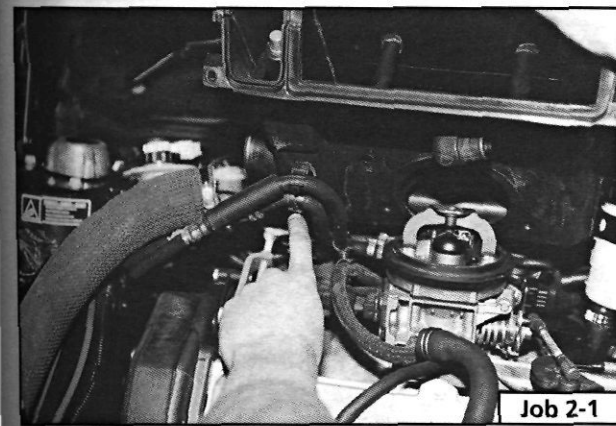

Q Step 1: Disconnect the battery earth lead, then remove the air cleaner. See Chapter 5, Servicing Your Car. Don't

forget to check for these hoses, fitted to the underside of the air filter housing.

Q Step 2: Disconnect coolant hoses from the carburettor body, and plug them.

CJ Step 3: Disconnect the throttle and choke controls. See Jobs 4 and 5.

LJ Step 4: Disconnect the fuel lines from the carburettor and plug the ends.

making it easy! insure that fuel delivery and return fuel lines are identified for refitting in their correct positions.

LJ Step 5: Unscrew the carburettor mounting nuts and remove the unit from the intake manifold.

Q Step 6: Clean the mating flanges, fit a new carburettor base gasket and refit/reconnect in the reverse order.

Job 3. Petrol injection unit - removal and refitting.

IMPORTANT NOTE: No adjustment or fault diagnosis of the petrol injection system is possible without the correct diagnostic equipment. We show how to replace the Single Point injection (S.P.I.) turret, but we still recommend taking your car to your FIAT dealer to have an apparent fault diagnosed before changing the injector turret.

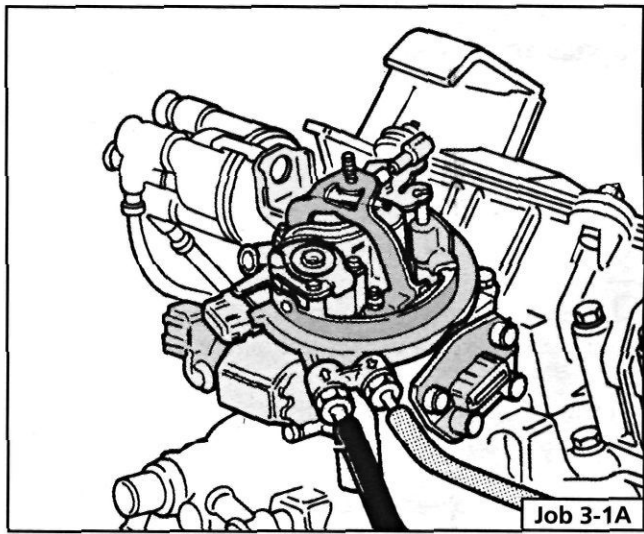

Q Step 1A: The single-point injection unit looks rather like a carburettor and is fitted on the inlet manifold. This view is from the rear of the engine.

- 1 - injection control unit
- 2 - butterfly valve angular position sensor (potentiometer)
- 3 - coolant temperature sensor
- 4 - petrol vapour cut-out solenoid valve
- 5 - current restricter resistor for injector
- 6 - electric fuel pump relay feed
- 7 - S.P.I, injection system relay feed
- 9 - fuel injector
- 10 - intake air temperature sensor
- 11 - fuel pressure regulator
- 12 - engine idle adjustment motor and CUT-OFF micro switch
- 13 - ignition coil
- 14 - diagnostic socket
- 15 - electric fuel pump protective fuse
- 16 - heated Lambda sensor protective fuse
- 17 - electric fuel pump
- 18 - Lambda sensor
- 20 - ignition switch
- 21 - battery
- 23 -RPM and T.D.C. sensor
- 24 - Mono-Jetronic failure warning light
- 25-fuel filter
- 26 - active charcoal filter
- 27 - multi-purpose valve
- 28 - tank ventilation and safety valve

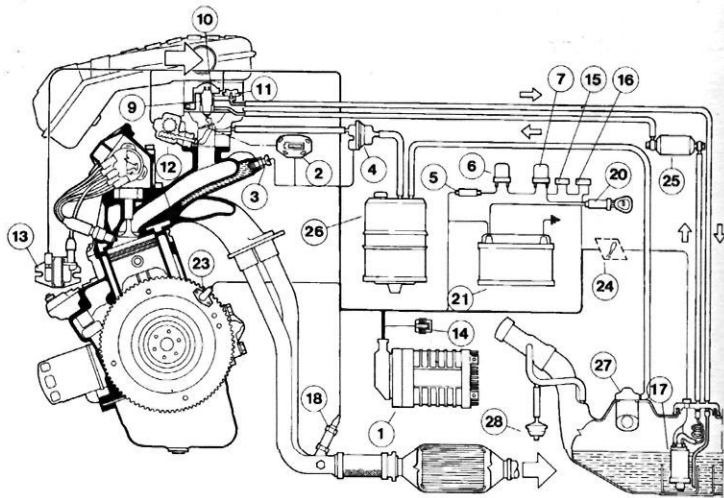

Job 3-1B

Step IB: This is the Bosch Mono-jetronic S.P.I, injection system, used on the 1372cc(1400cc) engine.

- 1 - fuel tank
- 2 - electric fuel pump
- 3-fuel filter
- 4 - fuel pressure regulator, integral with turret
- 5 - injector
- 6 - atmospheric safety valve
- 7 - breather float, vent and roll over cut-off valve
- 8-active charcoal filter
- 9 - petrol vapour cut out solenoid valve
- 10 - air temperature sensor
- 11 - butterfly valve opening sensor (potentiometer)
- 12 - engine idle adjustment motor and cut-off micro switch
- 13 - coolant temperature sensor
- 14- RPM sensor
- 15 - electronic control unit
- 16 - high tension coil
- 17 - system main relay
- 18 - electric pump relay
- 19 - Lambda sensor
- 20 - ignition switch
- 21 - battery
- 22 - additional resistance
- 23 -system fuse
- 24 - diagnostic socket
- 25 -warning light
- 26 - thermostatic duct

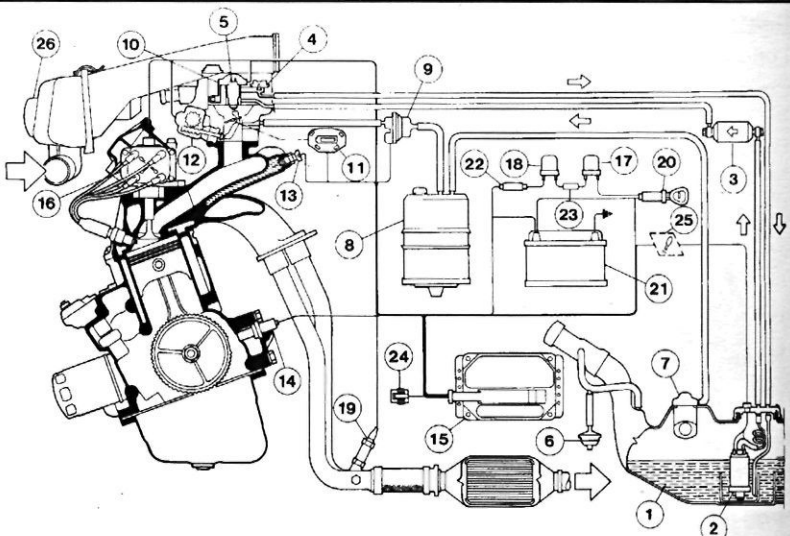

Job 3-1C

Step 1C: This is the Bosch Monomotronic electronic injection system, used on the 1581 cc (1600cc) engine.

Step 2: Disconnect the battery earth lead. Depressurise the fuel system - see **Job 9**.

Step 3: Remove the air cleaner assembly and the rubber sealing ring from around the top of the injection unit.

Step 4: Disconnect all electrical connections from the injector unit, making a written note of their positions.

Step 5: Release the clips and disconnect the fuel supply and return hoses from the unit.

Step 6: Disconnect the breather hose from the unit.

Step 7: Release the clip securing the throttle link rod to the injection unit throttle lever, then detach the link rod from the lever.

Step 8: Release the four Allen-type through-bolts in the top of the injection which retain it to the manifold, then lift the unit and its base gasket from the manifold.

Step 9: Refit in the reverse order, making sure mating faces are clean and the base gasket is new.

Step 10: Reconnect the battery earth lead.

Job 4. Accelerator cable, carburettor engines - replacement and adjustment.

Step 1: From under the bonnet, Slide the outer cable from its bracket (a) and detach the inner cable from the quadrant (b).

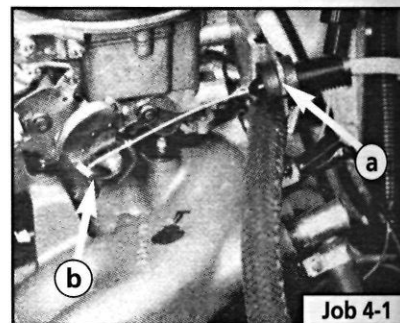

Job 4-1

LJ Step 2: From inside the car, unhook the cable nipple from the fork (arrowed) at the top of the pedal arm.

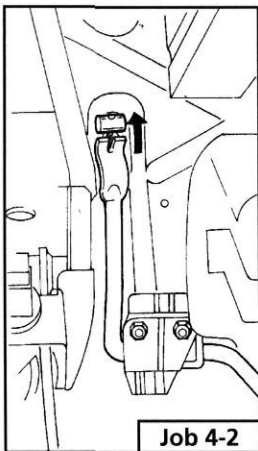

Job 4-2

J Step 3: Pull out the bulkhead grommet and release the cable.

making it easy!

• There are many different cables, so take your old cable as a pattern when buying a replacement to make sure the new one is exactly the same.

LJ Step 4: Refit in the reverse order - not forgetting the grommet in the bulkhead!

Q Step 5: Check that, when the new cable is fitted:

- there is just the slightest amount of free-play in the cable with the throttle closed.
- the carburettor lever is back against its stop with the throttle fully open.

Job 5. Carburettor choke cable - replacement and adjustment.

J Step 1: Remove the air cleaner See Chapter 5, Servicing Your Car and release the inner (a) and outer (b) cables from the carburettor screw-nipple and abutment clamp respectively.

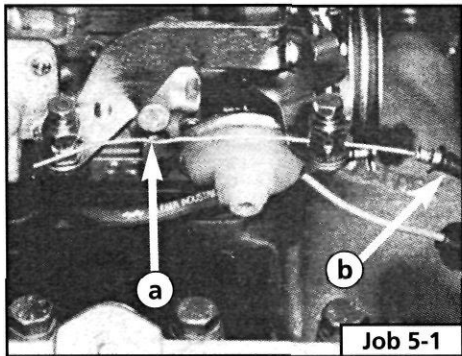

Job 5-1

G Step 2: From inside the car, pull the choke control lever fully out and undo its top hinge screw.

Q Step 3: Pull the choke cable assembly back far enough to unplug the warning light lead and release the inner cable from the lever.

Step 4: Pull the cable through the bulkhead.

G Step 5: Fit the new cable in reverse order. Pull out the choke lever inside the car by 2 to 3 mm before securing the inner cable at the carburettor end.

Job 6. Accelerator cable, petrol injection engines - replacement and adjustment.

• **Step 1:** Slacken the adjusting nuts (a) on the outer cable enough to allow you to disconnect the inner cable (b) from the quadrant (c) Remove the outer cable from its support bracket (d).

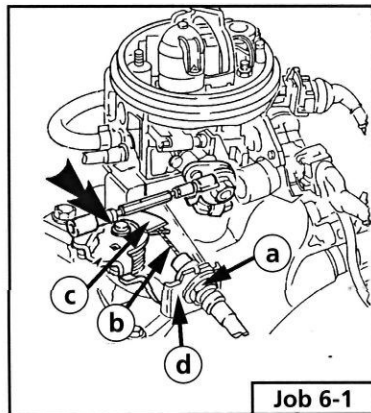

Job 6-1

Q Step 2: From inside the car, unhook the cable from the top of the accelerator pedal, as in Job 4-2.

Q Step 3: Pull the grommet out from the bulkhead and withdraw the cable into the engine compartment.

O Step 4: Refit in the reverse order.

Q Step 5: Make sure that the quadrant Job 6-1, part c is against its stop when at the same time there is no slack in the cable, allowing free play at the accelerator pedal.

LJ Step 6: Adjust the cable as necessary and re-check the quadrant position. Grease the quadrant pivot. See Job 6-1, arrowed.

Job 7. Diesel engines. Accelerator cable - replacement and adjustment.

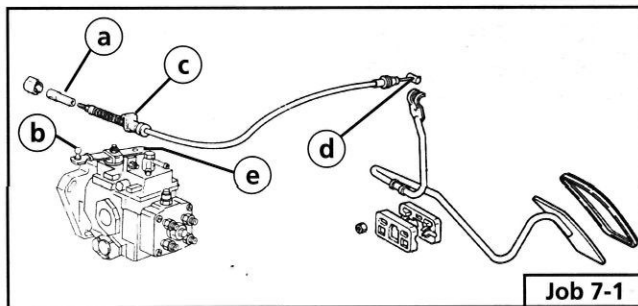

Job 7-1

Q Step 1: Part the inner cable end (a) from the balljoint (b) on the injection pump control lever. .. ^ . ^

Q Step 2: Remove the outer cable from its bracket by undoing the adjusting nuts, or by disconnecting the clip (c), according to type.

d Step 3: From inside the car, unhook the cable (d) from the top of the accelerator pedal.

Q Step 4: From under the bonnet, pull out the bulkhead grommet and withdraw the cable.

Q Step 5: Refit in reverse order and adjust so that the throttle lever (e) on the pump is allowed to go back to its tick-

6. LIGHTS AND INDICATORS

DIRECTION INDICATORS AND REAR FOG LIGHT SWITCH

The lights operate when the key is at the MAR position.

6A. The symbols on the stalk all illuminate when the side or headlights have been switched on.

- Turn the left-hand column stalk's knurled switch from OtoC. The panel indicator sidelight display will illuminate.

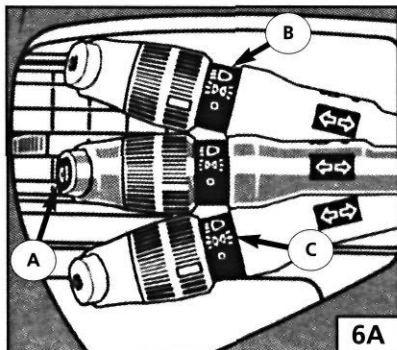

LOW BEAM HEADLIGHTS

- Turn the knurled switch from position C to B, for low beam headlight.

HIGH BEAM HEADLIGHTS

- When the knurled switch pointer is at position B, pull the stalk towards the steering wheel to switch the headlights to high beam.
- The panel full headlight beam LED will light up.
- Flick the stalk towards the steering wheel again to switch off the high beam headlights (the low beam headlights will remain on).

REAR FOG-GUARD LIGHTS

- Turn the knurled switch to B (low beam) and then press the rear fog switch A at the tip of the stalk to turn the rear fog-light on.

DIRECTION INDICATORS

Move the left-hand column stalk (from its centre position): • Up = right turn. • Down = left turn.

The panel direction indicator light flashes when the direction indicators are operating. The stalk returns to the centre position after completing the turn.

WINDSCREEN WASHER/WIPER CONTROLS

6B: WINDSCREEN WASHER/WIPER (FRONT)

The washer and wiper only operate when the key is positioned at MAR.

When the windscreen washer stalk is positioned at:

- 0 - The windscreen wiper is off.
- 1 - Intermittent operation (adjustable by turning switch C, from II to III).
- 2 - Continuous high speed operation.

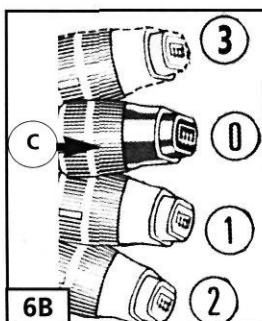

- 3 - Continuous operation (when the stalk is released the wiper turns OFF).

WINDSCREEN WASHER/WIPER (REAR)

6C. • Turn switch B from position 4 to position 5 to turn on the rear window wiper.

- Pull the stalk toward the steering wheel to turn on the rear window washer and wiper (continuous operation). Both the washer and wiper stop operating when the stalk is released.

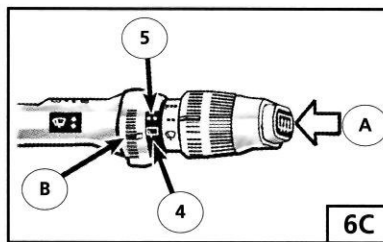

REAR WINDOW DEFROSTER

The defroster can only be operated when the key is in MAR:

Press switch A at the tip of the right-hand stalk to turn on the rear window defroster. The rear defroster LED panel indicator will illuminate.

HAZARD WARNING LIGHTS

6D. Press the hazard light switch (arrowed) to turn on the hazard warning lights. All the directional indicator lights and the panel indicator will flash. The hazard warning lights work whether the key is inserted or not.

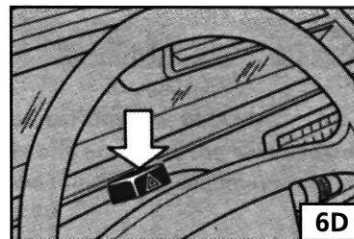

FRONT FOG LIGHTS

Press the front fog light switch (key at MAR, headlights on). The fog light panel indicator will illuminate.

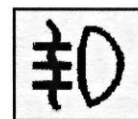

PANEL LIGHT DIMMER (DIGITAL INSTRUMENTS)

Press the panel light dimmer switch to adjust the panel backlighting level (key at MAR, headlights on).



FUEL CUT-OFF SWITCH

6E. Some models are fitted with a fuel cut-off device, which cuts the fuel supply off to the engine if the car is involved in a collision.

- If there are no signs of fuel leaks and the vehicle is in good enough condition to start again, reactivate the fuel feed system by pressing button A (arrowed), which is located underneath the passenger's seat.

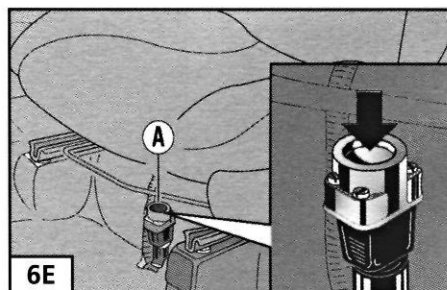

over stop and will also reach its 'maximum speed' stop with the pedal fully depressed.

Job 8. Mechanical fuel pump, petrol engine (carburettored) - replacement.

LJ Step 1: Disconnect the battery earth lead.

LJ Step 2: Find the pump on the forward facing side of the cylinder block near the timing cover end. Disconnect the two fuel lines from the pump and plug the ends, (labelling them for correct refitment).

LJ Step 3: Undo the two mounting bolts and remove the pump (a) and spacer block (b).

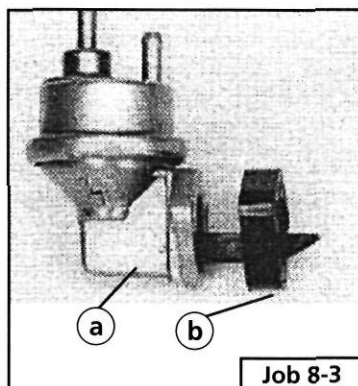

Job 8-3

LJ Step 4: Clean off any old gasket particles and refit in reverse order using new gaskets. Check that the hose connections are sound.

H INSIDE INFORMATION! Where the fuel pump is of the pushrod type, the inner gasket should always be 0.3 mm thick. The outer one is available in 0.3, 0.7 and 1.2 mm thicknesses from your FIAT dealer, allowing for fuel pressure adjustment. Pressure is higher with a thin gasket and lower with a thick one, and the correct pressure is 0.176 bar. Q

making it easy! ^m If you have a micrometer or a good vernier caliper, clean the old gaskets, measure their thickness, and fit new gaskets of the same thickness.

Job 9. Electric fuel pump, petrol engine (S.P.I.) - replacement.

• Depressurise the fuel system before starting work - this is important because fuel remains underpressure in the system long after the engine has been switched off.

LJ Step 1A: Depressurise the fuel system by unplugging the fuel pump relay (a) and running the engine until it stops. The relay (b) is for the injection system; (c) and (d) are fuses for the Lambda sensor and the fuel pump, respectively.

LJ Step 1B: Switch off the ignition and disconnect the battery leads, starting with the earth lead.

• Step 2: Lift the luggage compartment floor covering and remove the dust cover from above the fuel pump (arrowed).

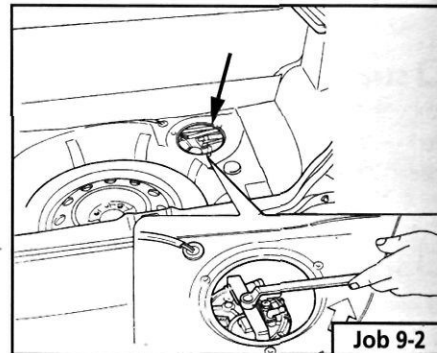

Job 9-2

• Step 3: Disconnect the electrical plugs from the pump and fuel gauge sender.

LJ Step 4: Unscrew the fuel gauge sender unit by twisting the two opposing lugs anti-clockwise.

Q INSIDE INFORMATION! FIAT use special tool for this (see illustration Job 9-2. inset) but it can be done without, by using a little care. Use two vertically held screwdrivers against the lugs and another levering between them as low as possible. Q

LJ Step 5: Remove the safety plate and disconnect the fuel supply pipe (the white union)...

LJ Step 6: ...and the return pipe (the black union).

LJ Step 7: Undo the large ring nut securing the pump to the tank, ideally, using tool 1854041000 and a polygonal spanner or by making up a tool of your own!

SAFETY FIRST!

• Do NOT drift the nut because of the risk of causing sparks.

LJ Step 8: Remove the pump from the fuel tank.

LJ Step 9: Refit in reverse order making sure all electrical and fuel connections are sound and correctly made.

LJ Step 10: Remember to refit the fuel pump relay and reconnect the battery.

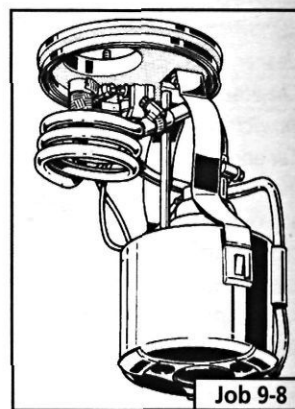

Job 9-8

SAFETY FIRST!

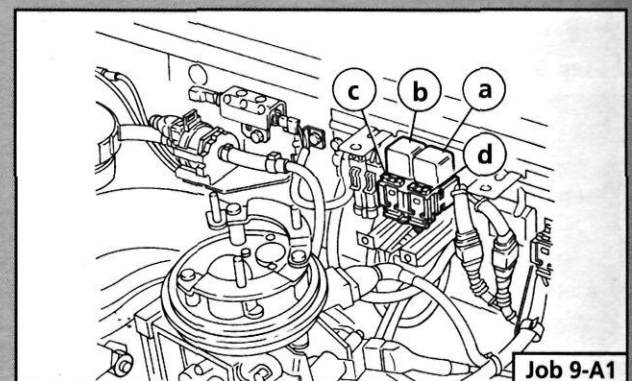

Job 9-A1

Job 10. Fuel tank - removal and refitting.

SAFETY FIRST!

- We recommend that you carry out all of this work outdoors.

IMPORTANT NOTE:

- Read **Chapter 1, Safety First!** before carrying out this work!
- Plan ahead! Run the fuel in the tank as low as possible before you start this job.

LJ Step 1: Disconnect the battery leads starting with the earth lead.

G Step 2: Syphon any remaining fuel from the tank and into a suitable closed container.

Q Step 3: Disconnect the fuel sender wiring and any fuel hoses from within the boot (model-dependent - see **Job 9** and **PAKTE: ELECTRICAL AND INSTRUMENTS, Job 14**).

Q Step 4: Disconnect the filler and breather hoses from the tank, working from underneath the car.

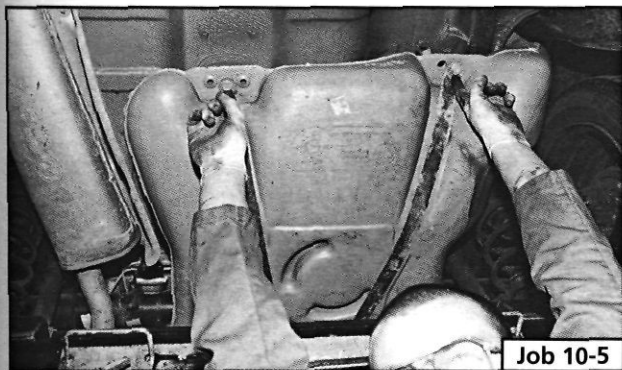

Job 10-5

EJ Step 5: Support the tank while undoing the strap securing bolts at the rear of the tank...

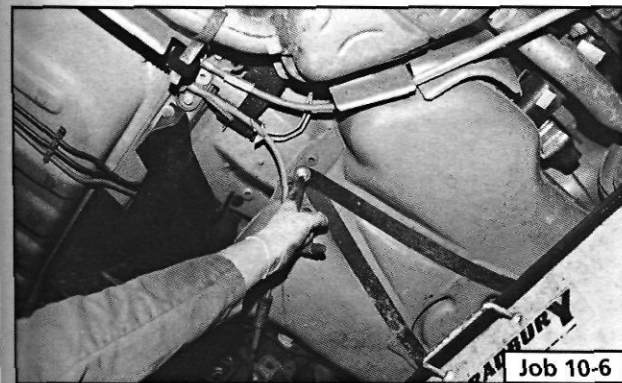

Job 10-6

J Step 6: ...and at the front.

V Step 7: Lower the tank a very small amount at a time, enough to check whether any hoses remain attached, then lower it fully to the ground.

Q Step 8: Refit in the reverse order, making sure all connections are sound. Reconnect the battery leads.

Job 11, Hot air hoses/thermo-valves - general.

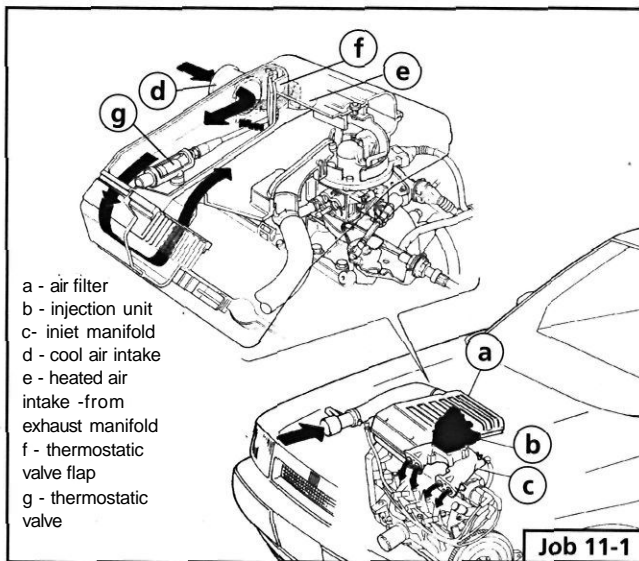

- a - air filter
- b - injection unit
- c - inlet manifold
- d - cool air intake
- e - heated air intake -from exhaust manifold
- f - thermostatic valve flap
- g - thermostatic valve

Job 11-1

- **Step 1: B INSIDE INFORMATION:** The good operation of the thermostatic valve in the air cleaner where the heated air pipe from the manifold enters the air filter) relies on air hoses that are in good condition. Replace any that are doubtful before suspecting the valve to be faulty. These valves usually give little trouble and usually only suffer from sticking, caused by dirt. Try cleaning the flap and hinge before assuming the worst! Q

Job 12. Lambda sensor (S.P.I, engines) - replacement.

J Step 1: The Lambda sensor can be found screwed into the exhaust just behind the point where the down pipes run into one (arrowed).



Job 12-1

LJ Step 2: Trace the wiring back from the sensor and disconnect the two plugs, (band c).

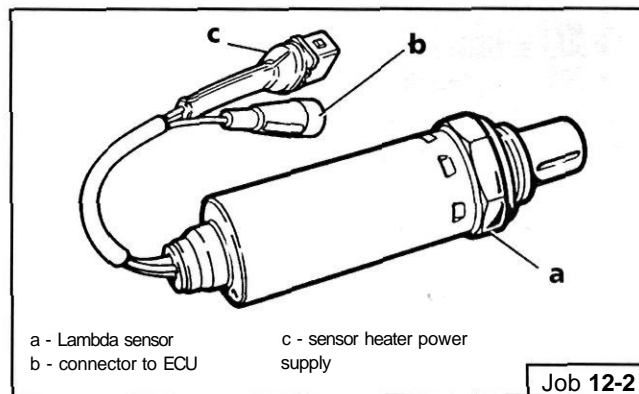

- a - Lambda sensor
- b - connector to ECU
- c - sensor heater power supply

Job 12-2

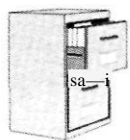

FACT FILE: LAMBDA SENSOR

- The Lambda sensor is very fragile and should not be knocked or dropped.
- We recommend that a new one is fitted only by your FIAT dealer, who can test the old one to see whether it is working properly.
- No cleaners should be used on the sensor.

LJ Step 3: Before refitting, check that the sensor sealing ring is in good condition, and lubricate the thread of the sensor with a high-temperature anti-seize compound.

Job 13. Fuel evaporation system.

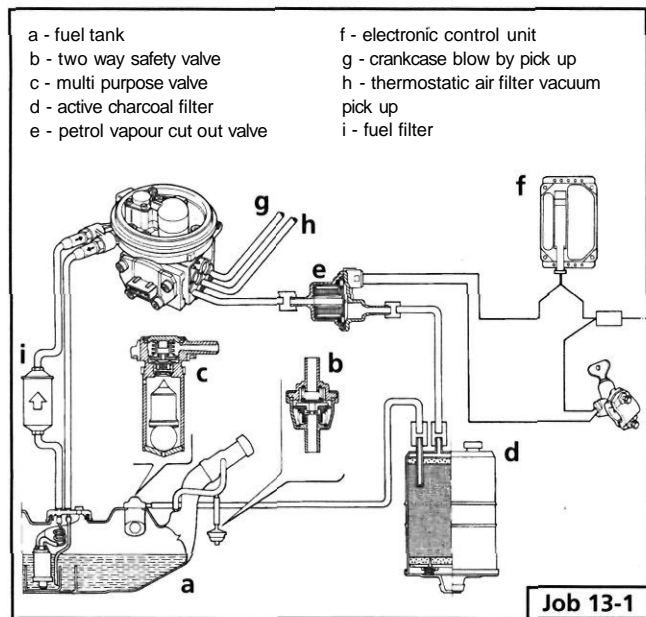

LJ Point 1: A complex control system exists to prevent evaporative losses of fuel vapour to the atmosphere, and to control fuel tank pressure under different temperature conditions.

LJ Point 2: The system comprises a charcoal canister which absorbs fuel vapour from the fuel tank, mostly while the vehicle is standing, then re-injects it when the engine is running. The valves which regulate the system are controlled by the engine's electronic control unit.

LJ Point 3: Other than occasional replacement of the charcoal canister, no system maintenance is needed. However, a fault with the system can lead to running problems, and diagnosis and rectification must be left to your FIAT dealer.

Job 14. Exhaust system - replacement.

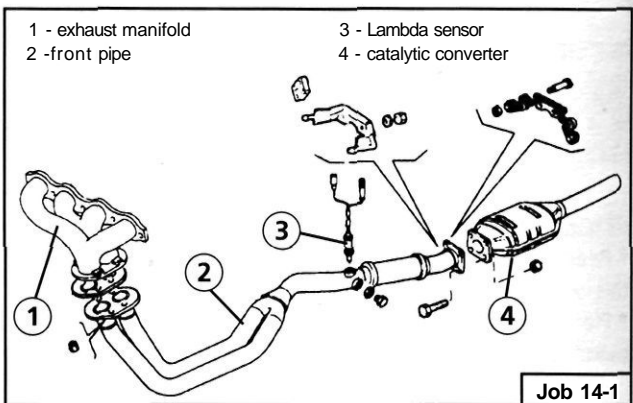

Step 1: Exhaust systems are similar in principle - and mostly in appearance - between engine types but differ in that some have a Lambda sensor, and a catalytic converter. This is a typical system.

Q Step 2: If a Lambda sensor is fitted, see **Job 12** for important information regarding removal.

d Step 3: Undo the downpipe to manifold flange bolts.

d Step 4: With a helper to support the weight, release the exhaust system from its mountings along its length and lower it to the ground.

d Step 5: Separate the sections if only part of the system is being replaced. Take care not to damage the catalytic converter if this is staying.

Q Step 6: Refit by starting at the front and fitting the down pipe using a new gasket, just nipping up the flange bolts.

d Step 7: Continue fitting loosely towards the rear until all is in place, using new gaskets and sealing compound, as required, for each of the joints.

LJ Step 8: Working from the front, align the system, tightening each flange or joint as you go.

LJ Step 9: Reconnect the Lambda sensor if fitted.

Job 15. Turbocharger, diesel engine - replacement.

G Step 1: Disconnect the battery earth lead.

- **Step 2:** Undo the two clips (arrowed - one at each end of the pipe) and remove the compressed air supply pipe, from intercooler to inlet manifold-

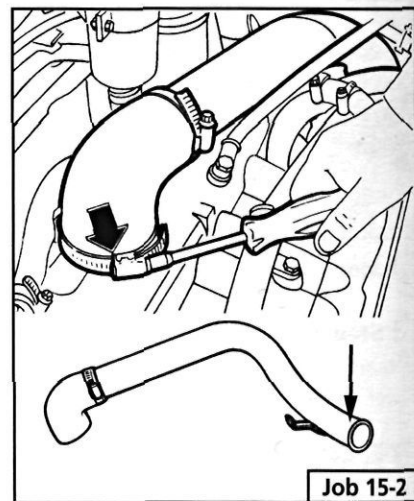

• **Step 3:** Undo clips securing the air intake pipe (a) and the crankcase breather pipe (b) and unbolt the securing bracket (d). Unbolt the pipe mounting (c) and remove the intake pipe.

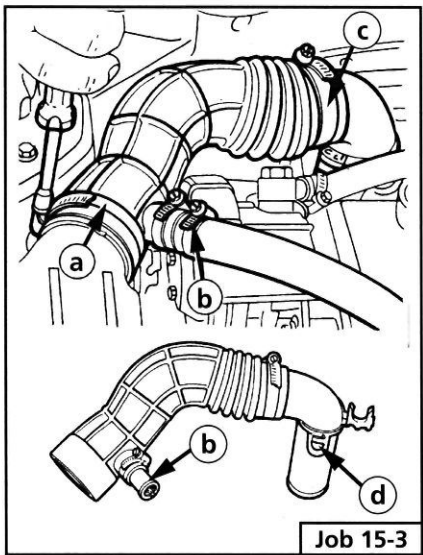

Job 15-3

• **Step 7:** Remove the two mounting bolts (a) and the adjusting bolts (b) and lay the pump clear - the hydraulic pipes should remain connected.

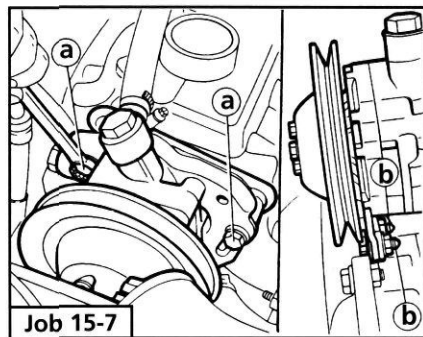

Job 15-7

• **Step 8:** Undo the clips and remove the compressed air supply pipe (inset) from between the turbocharger and intercooler.



Job 15-8

J Step 4: Remove the excess pressure pipe bolt (a) and unplug the wire from the high pressure warning light switch (b).

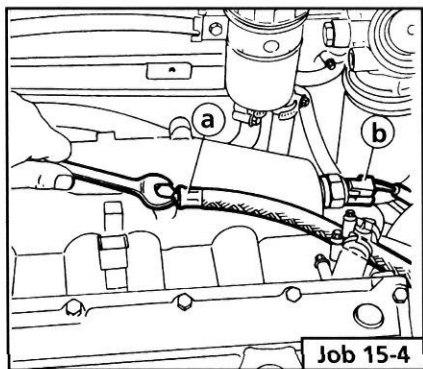

Job 15-4

• **Step 9:** Undo the three exhaust flange bolts (a) and lower the pipe enough to clear the manifold.

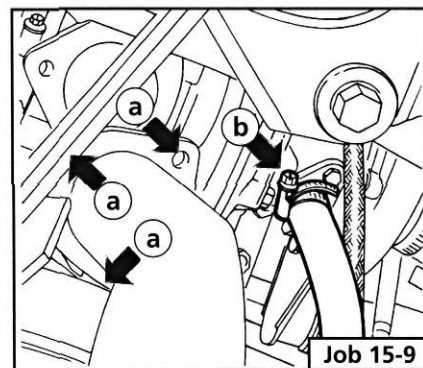

Job 15-9

J Step 10: Release the clip (illustration **Job 15-9, partfa**) and remove the oil return pipe from the turbocharger.

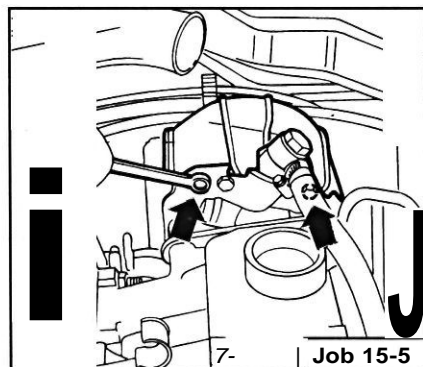

Job 15-5

• **Step 11:** Undo the bolts (arrowed) and remove the bracket between the exhaust manifold and crankcase.

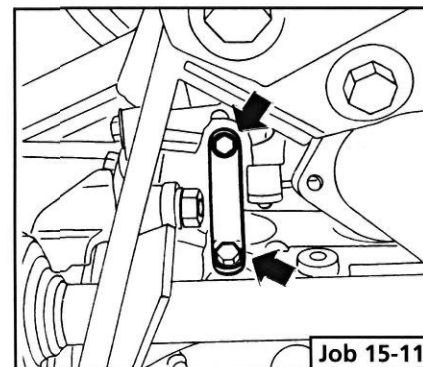

Job 15-11

U Step 12: Remove the inlet manifold by undoing the securing nuts (arrowed).

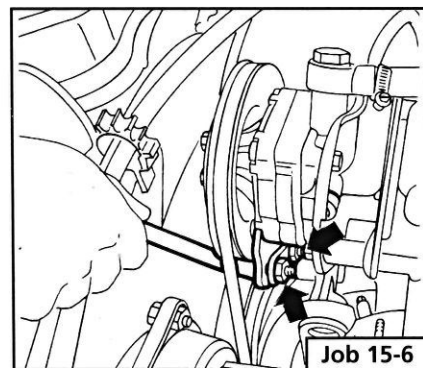

Job 15-6

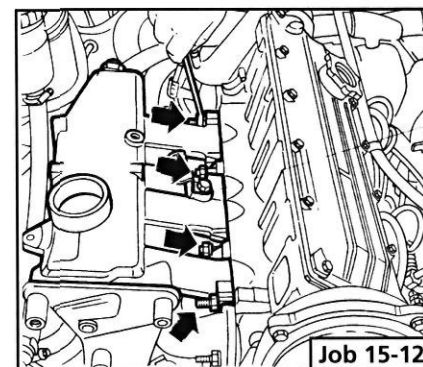

Job 15-12

I Step 13:
Remove the turbocharger oil feed union bolt (arrowed and inset).

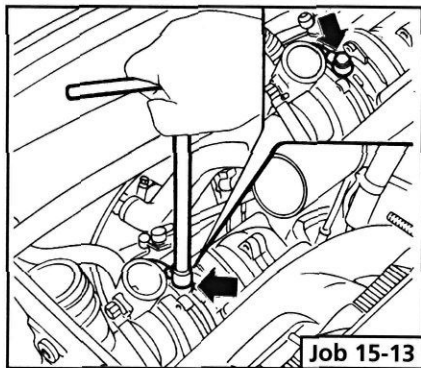

• **Step 14:**
Slacken the bolts (a) and swing the bracket in the direction of the arrow.

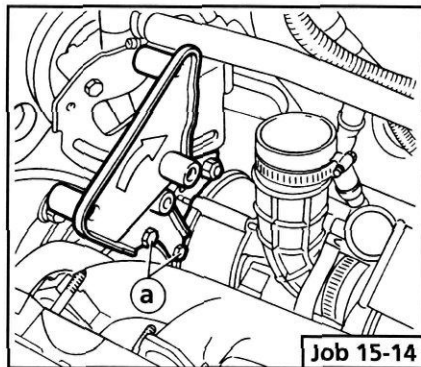

• **Step 15:** Undo the remaining exhaust manifold nuts, then remove the turbocharger complete with the exhaust manifold.

• **Step 16:** The two units can easily be separated once they are off the car.

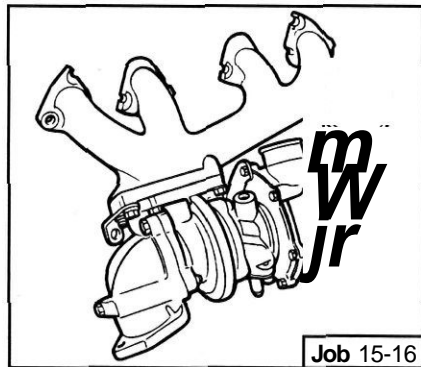

• **Step 17:**
Refitting is the reverse of removal.

Q INSIDE INFORMATION!
When refitting the pipes between the turbocharger and intercooler, and the intercooler and inlet manifold, the reference marks must align with the projection on the rigid sleeves. **Q**

Job 16. Diesel injection pump - removal and refitting.

SAFETY FIRST!

• Read and follow the information given in the **FACT FILE; FUEL INJECTION/ELECTRONIC IGNITION PRECAUTIONS**, and the **Safety First!** information following it, at the start of this chapter.

IMPORTANT NOTE:
This operation is the same for both turbo and non-turbo engines. The illustrations are of the turbo version.

• **Step 1:** Undo the pressure pipe union on the injector pump.

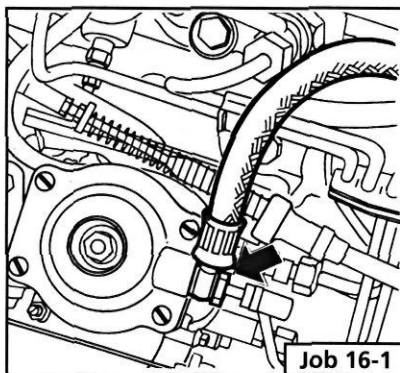

Q Step 2:
Disconnect the accelerator cable (1) and the fast idle control cable (2). (See also, **Job 6.**)

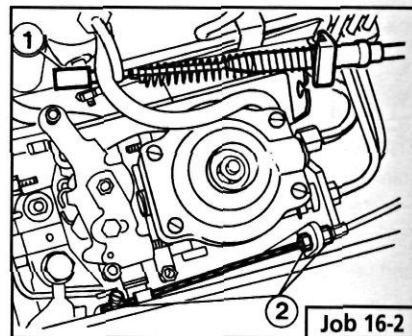

• **Step 3:** Undo the supply pipes from the injectors...

Q Step 4: ...and from the pump. Remove them from the car.

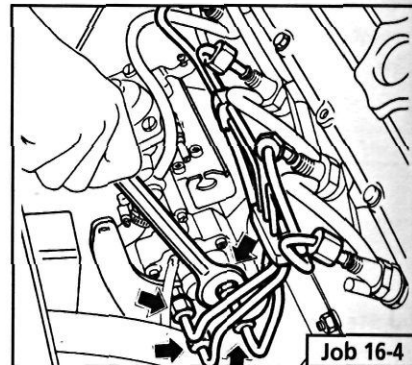

• **Step 5:** Undo the banjo union bolt (2 and inset) and remove the excess fuel discharge pipes (1 and 3).

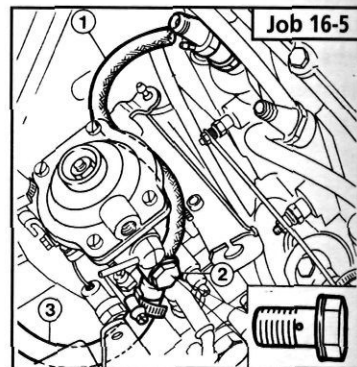

LJ Step 6: Now undo this banjo union bolt (arrowed and inset) and remove the fuel supply pipe from the injection pump.

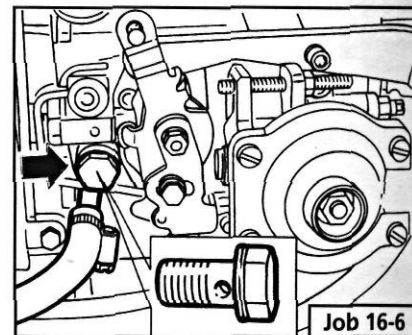

G Step 7:
Disconnect the engine cut out solenoid plug (arrowed)...

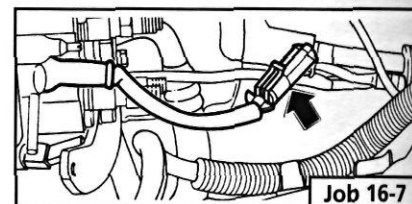

I Step 8: ...and the cold start device cable (arrowed).

• **Step 9:** Undo the bolts and remove the timing cover.

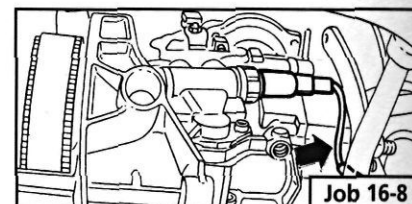

LJ Step 10: Slacken the timing belt tensioner nut and remove the belt.

making it easy ^m For the next two steps you will require special tools No. 1860765000 and No.

1842128000 to lock the sprocket and then remove it. If you cannot hire these from your FIAT dealer you will have to adapt existing tools that will function correctly and not cause damage. Otherwise, have your properly equipped FIAT dealer carry out the work for you.

- **Step 11:** Using the special tool, lock the sprocket and remove its fixing nut (arrowed).

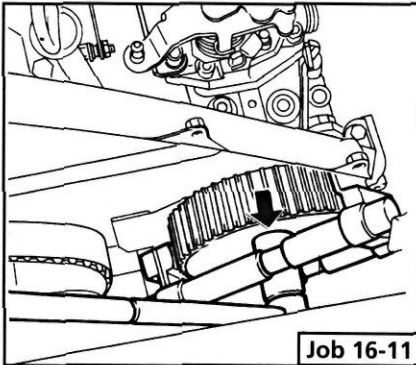

- **Step 12:** Using the second special tool, extract the sprocket (arrowed) from the pump shaft.

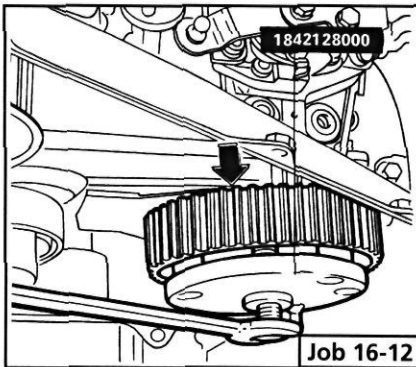

- **Step 13:** Undo the pump retaining bracket bolt (arrowed)...

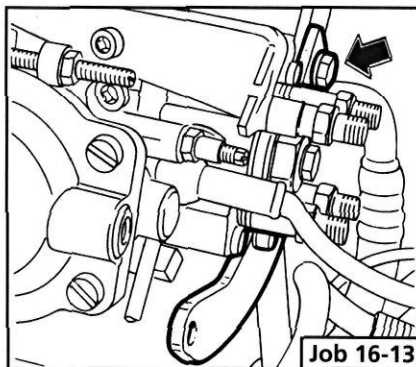

- **Step 14:** ...and the Allen screw (arrowed), fixing the pump to the mounting.

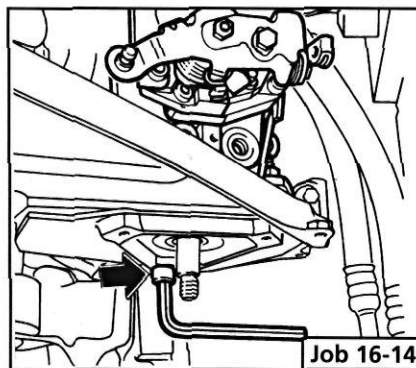

- **Step 15:** Remove the bolts (1 and 2) - pump to front retaining bracket. Remove the pump.

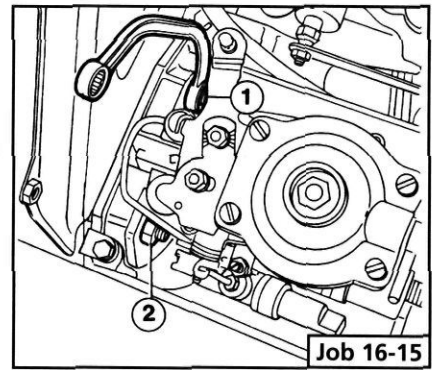

- **Step 16:** Q INSIDE INFORMATION: Remove the rear mounting bracket for use on the new pump, if the pump is being replaced. B

L) **Step 17:** Refit the pump in the reverse order of removal. Reset the timing as detailed in Step 18 onwards.

- **Step 18:** Align the timing mark on the pump sprocket with the reference mark on the rear cover (arrowed). Lock the sprocket in position with special tool no. 1842128000.

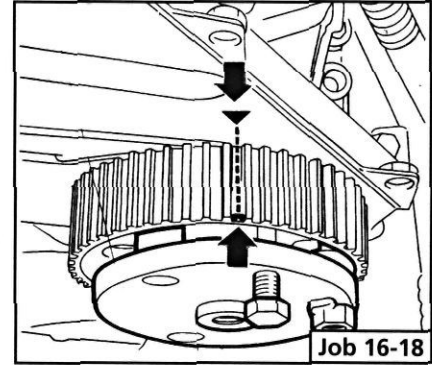

- **Step 19:** Make sure the crankshaft pulley reference marks are perfectly aligned.

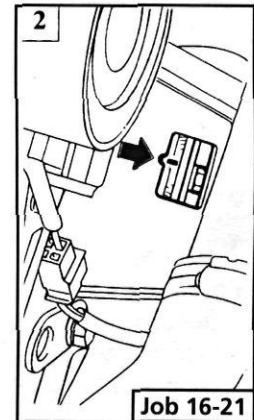
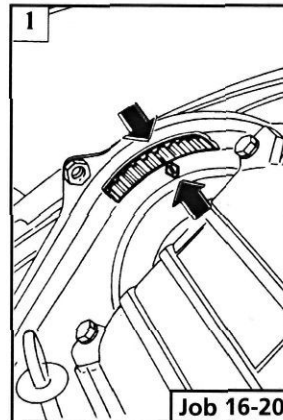
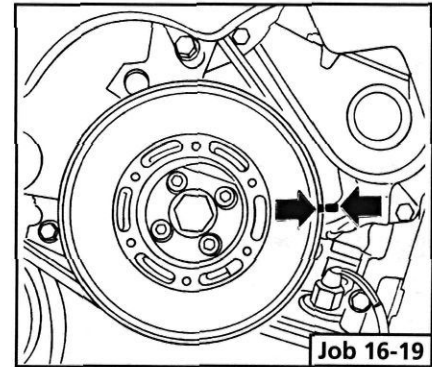

Q **Step 20:** Align the camshaft gear timing mark with that on the timing belt rear cover (arrowed)...

Q **Step 21:** ...and also check that the timing mark on the bell housing aligns with the mark on the flywheel (arrowed).

LJ Step 22: Inspect the timing belt and if -

- it is contaminated with any liquid,
- has damaged teeth,
- or frayed edges,
- or it has covered more than 30000 km,

- fit a new one.

Q INSIDE INFORMATION: Some FIAT mechanics recommend that the belt is replaced as a matter of course. The cost of a new belt compared to the cost of a damaged engine, makes it a false economy not to do so. **B**

CJ Step 23: Place the timing belt over the sprockets, keeping it tight on the run between the pump and camshaft.

Q Step 24: Push the adjusting pulley into the belt and nip up the lock nut. Without the aid of the special tool, the adjustment is roughly correct when you can twist the belt at its longest point between thumb and finger through a quarter turn (90 degrees).

LJ Step 25: Turn the engine two full revolutions, re-check the timing and belt tension. Adjust if necessary and tighten the adjusting pulley lock nut.

H INSIDE INFORMATION! CHECKING INJECTION ADVANCE. This cannot be done without the use of a dial gauge and special adapter to fit on the rear of the pump. We strongly recommend that although your engine may seem to be running well, you get it checked by your FIAT dealer. **H**

Job 17. Diesel injectors - remove and refit.

d Step 1: Clean thoroughly around each injector to prevent dirt from entering the cylinders when removing the injectors.

[] Step 2: Unscrew the fuel pipe union at the injector, using a flare nut wrench (split ring spanner).

Q Step 3: Loosen the union at the injection-pump-end of each injector pipe. Disconnect the fuel-return unions at the injector and move the return pipes away.

- **Step 4:** Unscrew the injector using a deep 27 mm A/F socket, or, preferably, a proper injector socket (arrowed). Collect the injector and its base washer. All seals should be renewed every time the injector is removed.

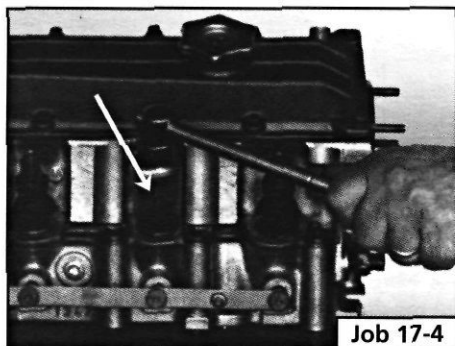

U Step 5: Thoroughly clean the injector before refitting, as dirt here can cause cylinder leakage, as can the re-use of a sealing washer, so always renew them.

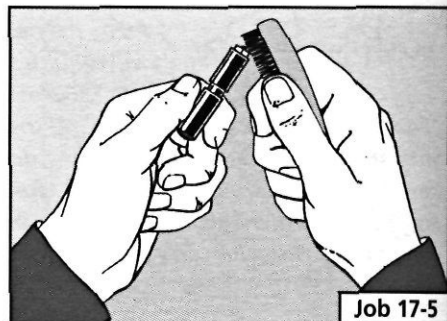

LJ Step 6: Injector efficiency and spray pattern can only be checked by your FIAT dealer, or a Diesel or injection specialist with test equipment. This is an inexpensive check to have carried out, while the injectors are out.

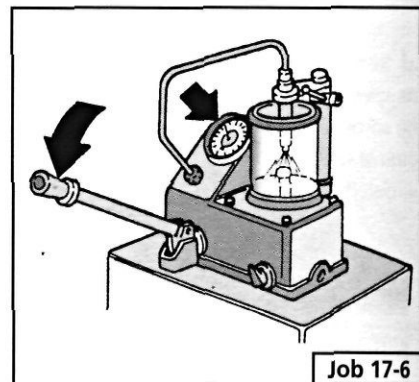

Q Step 7: Refit the injector, tightening it to the specified tightening torque. See *Chapter 3, Facts and Figures*.

LJ Step 8: Reconnect all parts in the reverse order. Run the engine at a fast idle initially to clear air from the high pressure side of the fuel system.

Job 18. Bleeding Diesel fuel system.

PART A: BLEEDING AIR FROM THE SYSTEM

If the engine stalls because of lack of fuel or if fuel low pressure lines have been disconnected or fuel filter has been changed, bleed the system as follows:

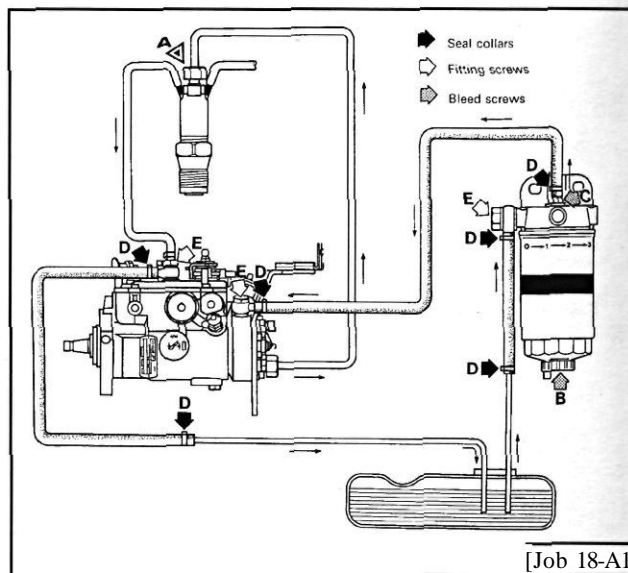

Q Step A1: Unscrew the unions fastening the delivery lines to the four injectors (A).

Q Step A2: Start the engine and run until fluid emerges from the loose injector fitting.

LI Step A3: Keep the engine running and tighten the four injector fittings.

D INSIDE INFORMATION: If the engine will not start, check all fuel inlet pipe union points (see illustration **Job 18-A1, part D**) and also the pipe fittings (**Job 18-A1, part E**). Replace seal washers to eliminate the possibility of air leaks. **Q**

PART B: BLEEDING WATER FROM DIESEL

Bleed off water from the fuel filter as follows:

LA Step B1: Unscrew the water bleed screw (**Job 18-A1, part B**) under the filter.

LA Step B2: Unscrew air bleed screw (**Job 18-A1, part 0**) above the filter.

LA Step B3: Let water and fuel emerge until no more water is present, then tighten, firstly the water bleed screw (B) under filter, and then the air bleed screw (C) above the filter.

PART G: STEERING AND SUSPENSION

PART C: Contents

- Job 1. The systems explained.
- Job 2. Steering wheel - removal and refitting.
- Job 3. Track rod end balljoint - replacement.
- Job 4. Steering rack gaiter - replacement.
- Job 5. Steering rack - replacement.
- Job 6. Power steering pump - removal and refitting.
- Job 7. Lower wishbone - replacement.

- Job 8. Bleeding the power steering.
- Job 9. Front anti-roll bar - removal and refitting.
- Job 10. Rear anti-roll bar (when fitted).
- Job 11. Front shock absorber - replacement.
- Job 12. Front wheel bearing - replacement.
- Job 13. Rear shock absorbers and coil springs - replacement.
- Job 14. Rear suspension and wheel bearings - replacement.

Job 1. The systems explained.

The following drawings should be followed in connection with the relevant Jobs in this Part of the manual.

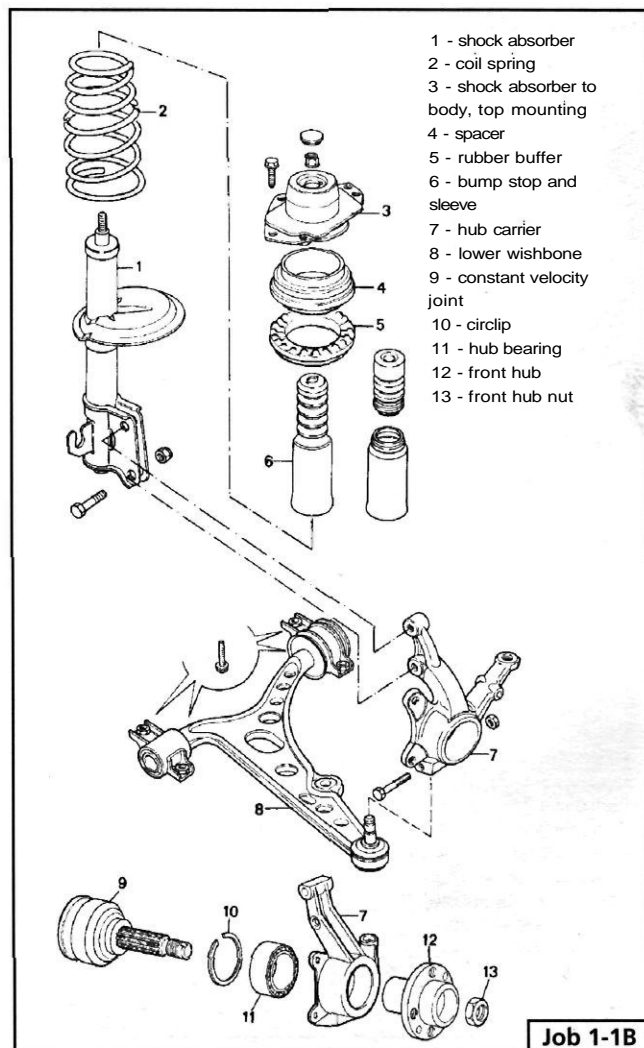
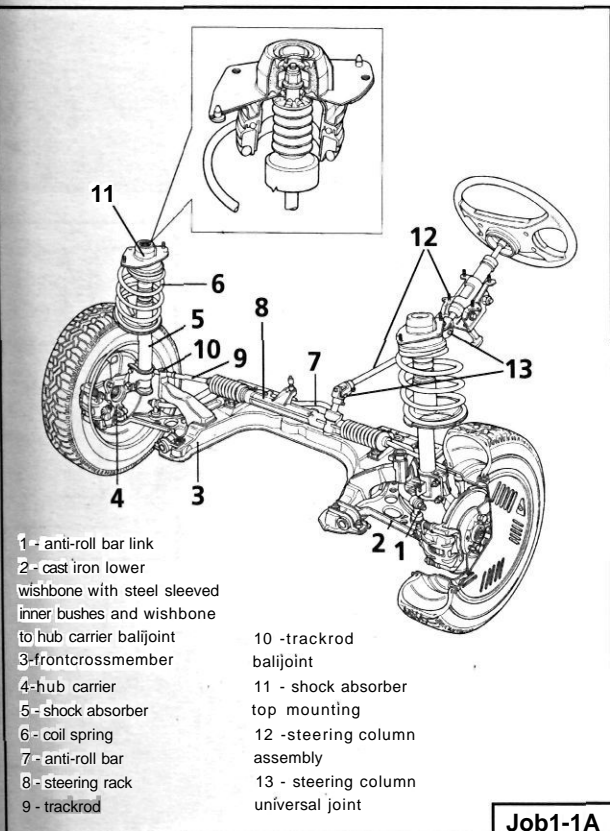

Q Point 1A: All the Tipo and Tempra front suspension and steering layouts are virtually identical. This is the general layout, shown here without power steering and in left-hand drive form.

Q Point 1B: This is a breakdown of front suspension components available as spare parts from FIAT.

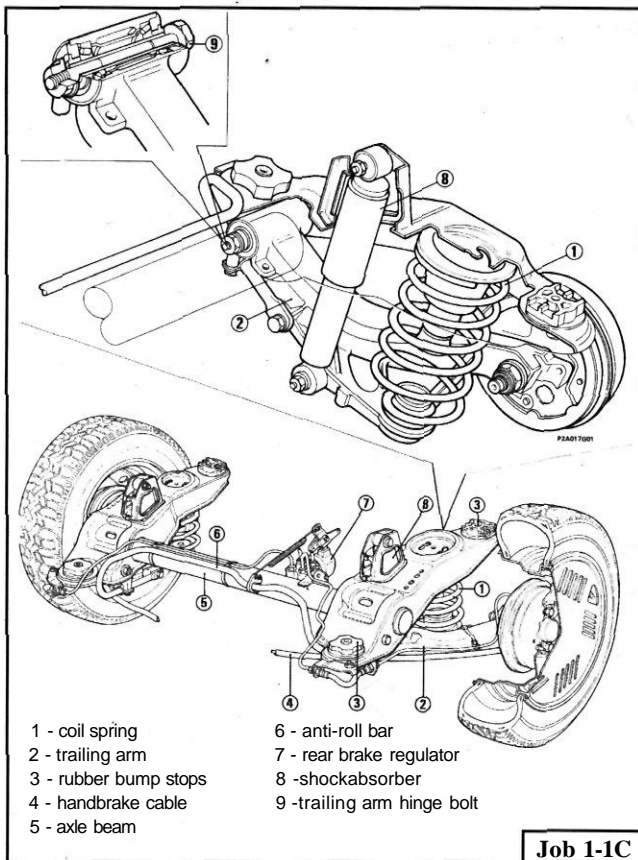

Job 1-1C

U Point 1C: The rear suspension design shown here is common to both Tipo and Tempra.

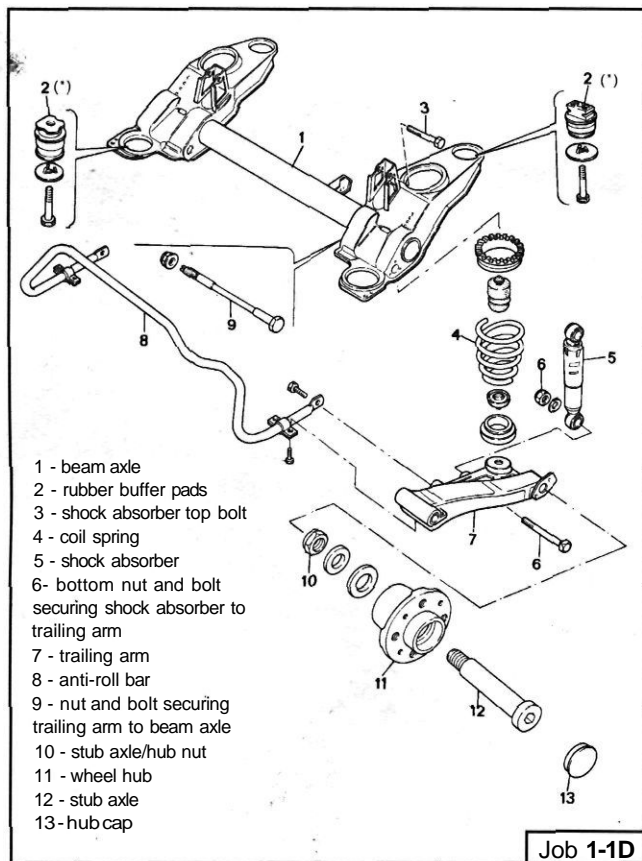

Job 1-1D

Q Point ID: This exploded drawing of the rear suspension gives a clear view of how several of the assemblies are fitted.

Job 2. Steering wheel - removal and refitting.

SAFETY FIRST!

• **AIRBAGS.** Because of the safety hazards, both mechanical and chemical (the air bag contains an explosive device) - we strongly recommend that a car with an air bag fitted to its steering wheel should be taken to a FIAT dealer to have its steering wheel removed and refitted under controlled conditions.

STEERING WHEELS WITHOUT AIR BAGS ONLY

d Step 1: Undo the wheel cover fixing bolts (positions arrowed) from underneath.

LJ Step 2: Using a ring spanner or socket and supporting the wheel with the other hand (see illustration **Job 2-1**), undo the centre fixing nut and remove the steering wheel.



Job 2-1

B INSIDE INFORMATION!

Never use the steering column lock to stop the wheel turning when removing and refitting the centre nut-this could cause damage and would be a costly mistake. **B**

LJ Step 3: Refit in reverse order, tightening the fixing nut to its specified torque. See *Chapter 3, Facts and Figures*.

Job 3. Track rod end balljoint - replacement.

Q Step 1: Slacken the roadwheel nuts on the side to be worked.

[L Step 2: Jack up and support the car on axle stands and remove the road wheel.

LJ Step 3: Slacken the lock nut (arrowed) on the track rod by just enough to free the balljoint, but no more.

Q Step 4: Now undo the balljoint to steering arm nut until the bottom of the nut is level with the end of the thread.

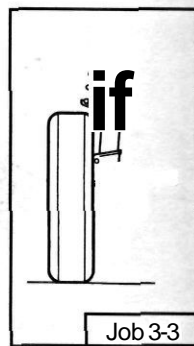

Job 3-3

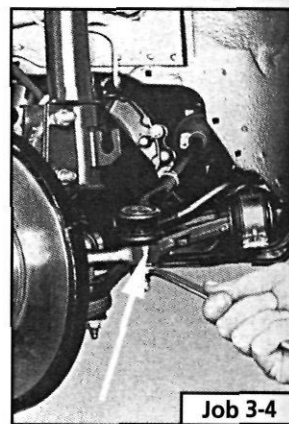

Job 3-4

0 Step 5: Use a suitable splitter tool to break the grip of the taper, remove the securing nut and withdraw the balljoint from the steering arm.

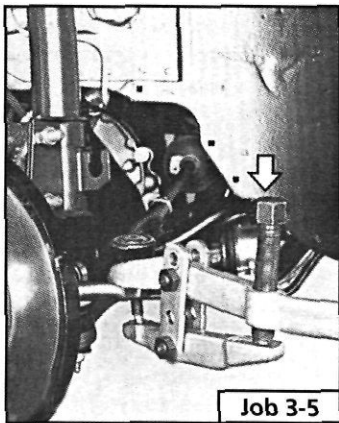

Job 3-5

H INSIDE INFORMATION:

If the balljoint taper proves stubborn, a sharp blow with a hammer to the side of the eye (see illustration **Job 3-4**, **arrowed**) momentarily distorts the eye and releases the taper. **Q**

Step 6: Unscrew the balljoint from the trackrod.

Q Step 7: Clean and grease the tie bar threads before fitting the new balljoint to prevent future seizure. Fit the new balljoint in reverse order and tighten the nuts to their specified torque. See Chapter 3, *Facts and Figures*.

IMPORTANT NOTE: Before using the car further, take it to your FIAT dealership or tyre specialist to have the front wheel alignment set. This is NOT a job you can do at home but it DOES need doing as soon as possible to avoid severe tyre wear and dangerous braking and steering!

Q Step 8: Refit and tighten the road wheel, and lower the car to the ground.

Job 4. Steering rack gaiter - replacement.

Step 1: Note the location of the steering rack gaiters under the car. **ONLY** carry out this work when the exhaust system is cold. Remove the Track Rod End (TRE) balljoint. See Job 3.

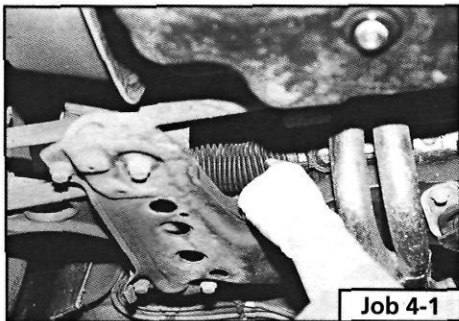

Job 4-1

Step 2: Undo the securing clip from each end of the gaiter and pull the gaiter off the tie rod.

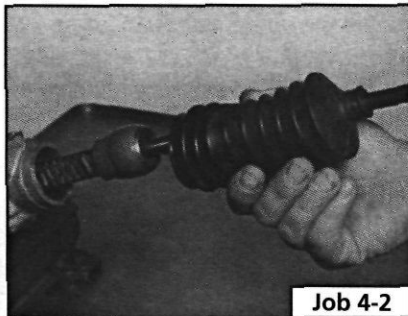

Job 4-2

Q Step 3: Wipe away contaminated grease and replace with new (lithium-based molybdenum disulphide grease). Secure the new gaiter in position at both ends with new bands or screw-type clips.

CJ Step 4: Complete the reassembly in the reverse order.

Step 5: Refit the TRE balljoint. See Job 3.

Job 5. Steering rack - replacement.

PART A: NON-POWER STEERING

CJ Step A1: Raise the front of the car and support securely on axle stands. Remove the road wheels.

Step A2: Disconnect the trackrod ends from the steering arms. See Job 3.

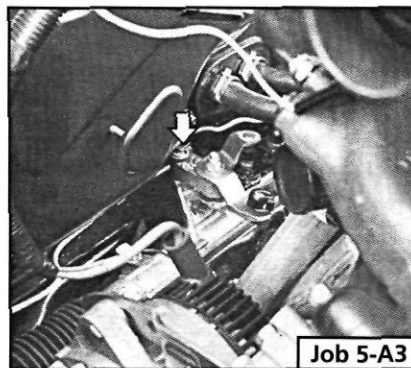

Job 5-A3

Step A3: From under the bonnet, undo the gear change mechanism fixing (arrowed) and remove the gear selector mounting.

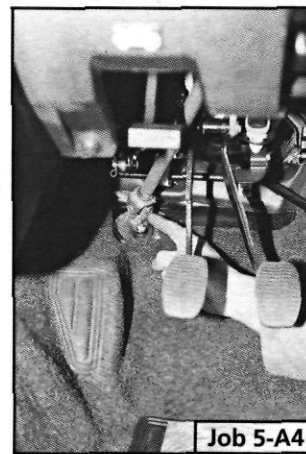

Job 5-A4

Q Step A4: From inside the car, undo the pinch bolt securing the universal joint to the rack pinion.

Step A5: Undo the steering rack mounting bolts (arrowed).

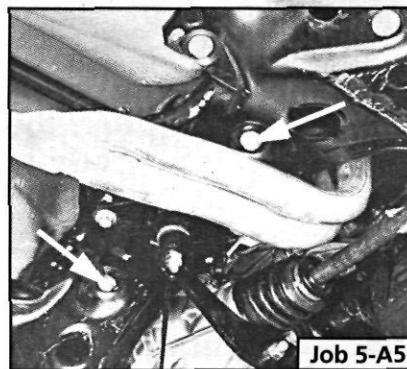

Job 5-A5

Step A6: With an assistant inside the car, helping to separate the steering column pinch-joint from the rack pinion, pull the rack assembly away from the bulkhead...

Step A7: ...and withdraw it from beneath a wheel arch.

making it easy!

Step A8: The replacement track should be centred before installation.

Measure the total travel of a TRE when moved from lock to lock. Go back half this distance, tighten the mounting bolts, and your rack is centred.

LJ Step A9: Place the steering wheel in the dead ahead position and engage the rack pinion splines with the column coupling.

LJ Step A10: Continue refitting in the reverse order of removal.

[J Step A11: Take your car to your nearest FIAT dealership or tyre specialist to have the front wheel alignment set before using the car further. This is NOT a job you can do at home but is DOES need doing as soon as possible to avoid severe tyre wear and dangerous braking and steering!

PART B: POWER STEERING RACK

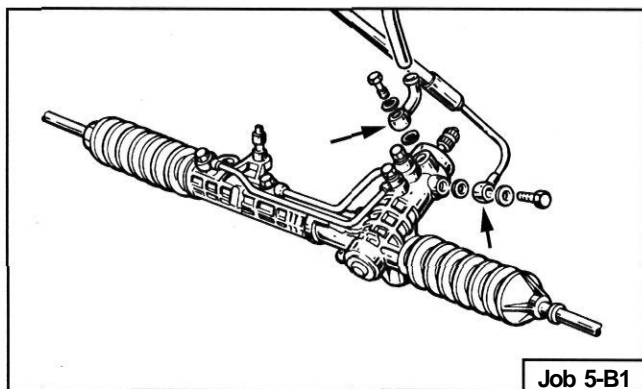

Job 5-B1

LJ Step B1: This is the layout of the power steering rack. The hydraulic pipe unions (arrowed) must be disconnected and the fluid drained, before the rack can be removed. See Job 6 for details of how to refill and bleed the system.

You must take care to:

- remove the union sealing rings - two for each union - and renew them.
- seal the open ends of pipes and connections with masking tape so that no dirt or other contamination can get in.

IMPORTANT NOTE: Stiffening-up of the steering may be due to either the pump control pulley belt slipping or insufficient oil. Check before assuming that the pump or rack is faulty. If either the pump or the power rack should fail, the power assisted steering will operate like a normal mechanical steering box, except that it may be higher geared and therefore more difficult to turn.

Job 6. Power steering pump - removal and refitting.

IMPORTANT NOTE: The power steering pump cannot be rebuilt, even by a FIAT dealer. Have its pressure tested by your dealer but replace or exchange the unit.

LJ Step 1: Remove the coolant pump/alternator drivebelt. See Chapter 5, Job 26.

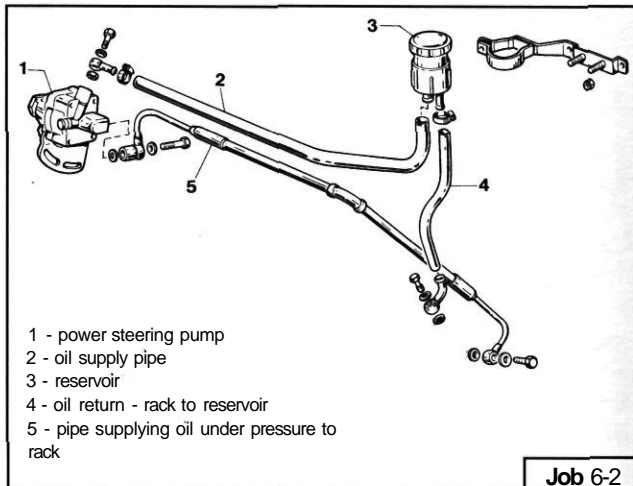

- 1 - power steering pump
- 2 - oil supply pipe
- 3 - reservoir
- 4 - oil return - rack to reservoir
- 5 - pipe supplying oil under pressure to rack

Job 6-2

LJ Step 2: Remove the unions from the two fluid pipes (2 and 5) from the pump (1) and remove the two sealing washers from each union.

LJ Step 3: Slacken the power steering pump pivot/attachment bolts, swivel the pump and remove the drivebelt.

LJ Step 4: Unbolt and remove the pump.

• **Step 5: Q INSIDE INFORMATION:** If you prefer, you can unbolt the mounting brackets from the pump and unbolt the drivebelt guard, after removing the pulley. **D**

LJ Step 6: When refitting, be sure to use new sealing washers on the unions and adjust the belt correctly, as described in Chapter 5, Job 26.

Job 7. Lower wishbone - replacement.

[J Step 1: Remove the nut (2) and the pinch bolt (7) and remove the balljoint (arrowed) from the hub carrier (1).

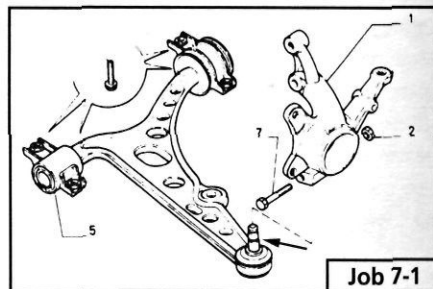

Job 7-1

LJ Step 2: Undo the bottom nut on the anti-roll bar link, retrieve the bushes and washers.

LJ Step 3: Undo the four mounting bolts (arrowed) and withdraw the wishbone from the car.

B INSIDE INFORMATION! If either the balljoint or inboard mountings become worn, the whole wishbone will have to be changed as an assembly. **Q**

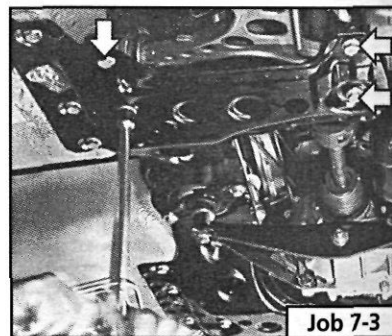

Job 7-3

LJ Step 4: Re-assemble in the reverse order using torque settings shown in *Chapter 3, Facts and Figures*.

Job 8. Bleeding the power steering.

The power assisted steering system is self-bleeding. You should slowly apply full lock alternately to the right and left with the car stationary and the engine running, while an assistant tops up the reservoir. This operation should be carried out each time the connecting pipes are removed or refitted.

Job 9. Front anti-roll bar - removal and refitting.

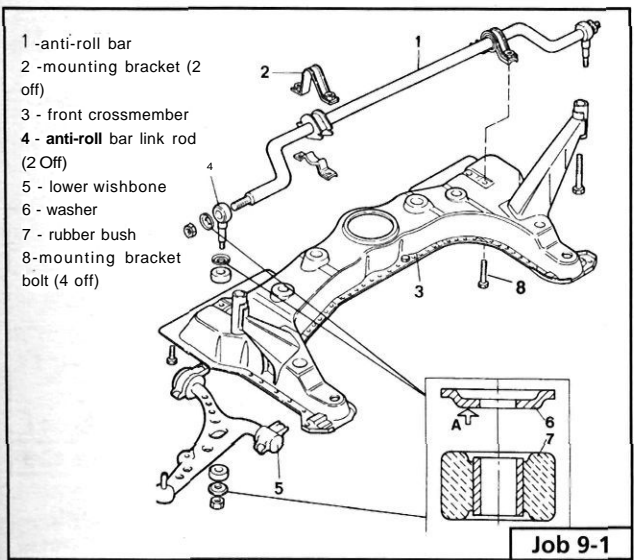

- LJ Step 1:** Take note of the components shown here.
- LJ Step 2:** Support the car on axle stands and remove the front wheels for access.
- LJ Step 3:** Undo the nuts at the bottom of the anti-roll links (see illustration *Job 9-1, part 4*).
- LJ Step 4:** Undo the four bolts securing the two mounting brackets (*Job 9-1, part 8*) and remove the anti-roll bar.
- LJ Step 5:** Before refitting, check the condition of the rubber mounting blocks and bushes and replace if necessary.

B INSIDE INFORMATION! The washers (*Job 9-1, part 6*) must be fitted with their convex side facing the rubber bush (*part 7*). **H**

Job 10. Rear anti-roll bar (when fitted).

- Q Step 1:** Support the rear of the car on axle stands.
- LJ Step 2:** Remove the fuel tank as described in *PART F: FUELANDEXHAUST, Job 10*.

LJ Step 3: Undo the three mounting bolts from each side (see illustration *Job 1-1D*) and wriggle the anti-roll bar from under the car.

LJ Step 4: Check the anti-roll bar for obvious distortion or corrosion and the bushes for deterioration. Replace if necessary.

LJ Step 5: Refit in reverse order.

Job 11. Front shock absorber - replacement.

LJ Step 1: Slacken the bolts of the relevant front wheel, then raise the front of the car and support on axle stands, so that the front wheels hang free. See *Chapter 1, Safety First!*

LJ Step 2: Remove the relevant wheel then detach the brake hose from the suspension strut bracket.

LJ Step 3: Remove the two bolts ('spannered' and arrowed) which secure the hub carrier to the base of the shock absorber and separate them.

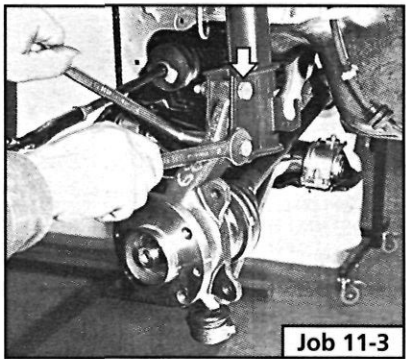

LJ Step 4: Working under-bonnet, undo the three bolts ('spannered' and arrowed) securing the top mounting to the bodywork turret.

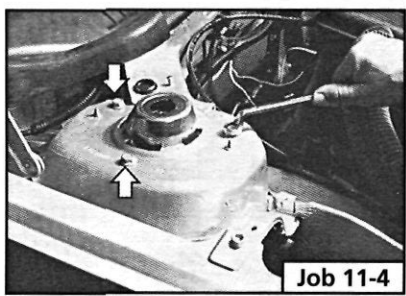

LJ Step 5: Lower the suspension strut to the ground.

LJ Step 6: Using two coil spring compressors spread over as many spring coils as possible, compress the spring, tightening each compressor a little at a time, in turn, until the spring ends are free of their seats.

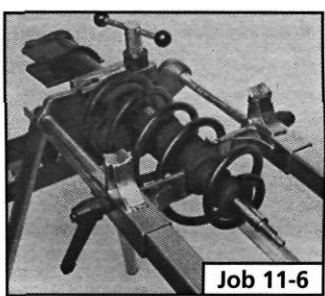

SAFETY FIRST!

- Because of the irregular shape of the top end of the spring coils, it can be difficult to use spring compressorssafely.
- We recommend having this work carried out by your FIAT agent with the correct compressing tool.

• **Step 7: H INSIDE INFORMATION!** Special tool, FIAT no. 1857509000 is required together with another tool, no. 1874551000 in order to prevent the centre rod from

turning while undoing the large nut that secures the top mounting - or ask your FIAT dealer to do it for you. **Q**

- **Step 8:** Refer to *Job 1-1B*. Pull off the mounting (3), spacer (4), rubber buffer (5), stop buffer and sleeve (6) and the coil spring (2).



FACT FILE: COIL SPRINGS

If a coil spring is cracked, sagged or heavily rusted, replace the front springs AS A PAIR. FIAT springs are colour-coded with a stripe of either yellow or green paint. Use only a matching pair.

SAFETY FIRST!

- Never undo the centre nut (**Steps 7 and 8**) without using a suitable spring compressor.
- The power contained within the spring is enormous and extremely dangerous.
- If you are not trained or experienced in this part of the job, leave it to your FIAT dealer.

LJ Step 9: Refit all components in reverse order, making sure the coil spring is properly seated with the targe coil at the bottom and the end of the coil, tight against the stop in the spring seat. Tighten to the specified tightening torques (see **Chapter 3, Facts and Figures**) only when the car is back on its wheels.

Job 12. Front wheel bearing - replacement.

IMPORTANT NOTE: The wheel bearing will probably be destroyed as it is removed from the hub.

making it easy!

• The hub and bearing can be drifted out from the hub carrier.

• If you have difficulty doing so, you could remove the hub carrier and take it to your FIAT dealer for bearing replacement.

- **Step 1: B** **INSIDE INFORMATION:**
- The hub nut (see illustration **Job 12-9, part f**) requires a great deal of torque to undo!
- Lever off the dust cap and slacken the centre hub nut (see illustration **Job 1-1B, part 13**) while the car is still on the ground.
- Try to lift the staking from the groove in the drive-shaft. If it won't all come clear, don't worry! It will unroll as the nut is undone.
- You will need an extra-long lever (about half-a-metre long) to undo the hub nut.
- Slacken the wheel bolts while the car is on the ground. **Q**

LJ Step 2: Raise and support the car on axle stands. Remove the road wheel. Remove the hub/drive-shaft nut.

LJ Step 3: Undo the brake caliper and the bracket retaining bolts. Move the caliper clear, still connected to the hose but not putting weight on it. See **PARTH: BRAKES, Job 3**.

LJ Step 4: Undo the two bolts and remove the brake disc...

• **Step 5:** ...and then the disc shield (arrowed).

• **Step 6:** Undo the nut and disconnect the trackrod balljoint using a splitter tool. See **Job 3**.

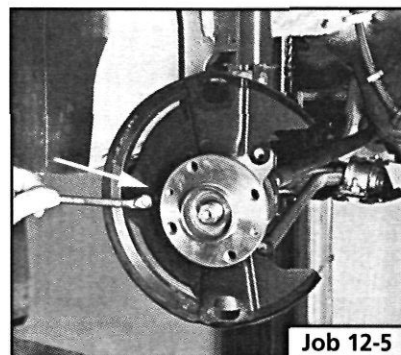

Job 12-5

LJ Step 7: Remove the two bolts securing the hub carrier to the shock absorber and pull the hub carrier clear. See **Job 11**.

LJ Step 8: Undo the pinch bolt fixing the lower wishbone balljoint pin to the hub carrier and part the carrier from the wishbone. See **Job 7**.

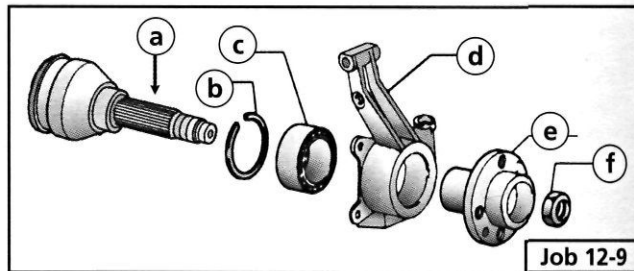

Job 12-9

LJ Step 9: Carefully withdraw the hub carrier - complete with hub and bearing (parts b to e, inclusive) - from the drive-shaft CV joint (a) and take to the bench.

LJ Step 10: Using a suitable press or a large vice, push the hub (see illustration **Job 12-9, part e**) from the carrier (part d).

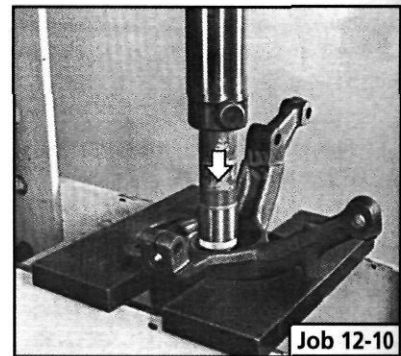

Job 12-10

Q INSIDE INFORMATION: This is the point at which the bearing will probably be destroyed, the outer remaining in the hub carrier and the inner on the hub. **Q**

• **Step 11:** Start the separation of the bearing inner track by use of a hammer and keen bladed chisel...

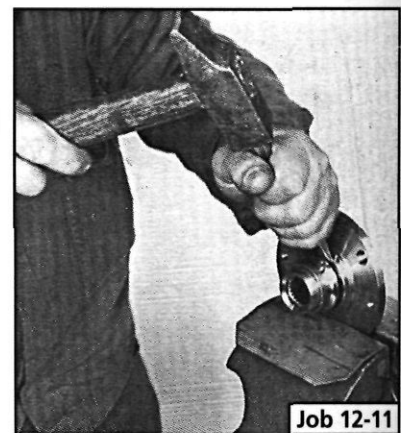

Job 12-11

Job 13. Rear shock absorbers and coil springs - replacement.

G Step 1: Refer to the drawings Job 7-JCand 1-1D.

IG Step 2: Leave the weight on the suspension by means of a jack under the trailing arm (see illustration Job 1-1C, part 2).

d Step 3: Undo the nuts (see illustration Job 1-1D, part 6) and washers retaining the shock absorber (Job 1-1D, part 5).

G Step 4: Pull the shock absorber off the top and bottom mounting studs and carefully lower the jack to release the pressure on, and then withdraw the coil spring. See also Job 11.

G Step 5: Refit in reverse order making sure that the coil spring is properly seated top and bottom and that the shock absorber nuts are tightened to the correct torque. See Chapter 3, Facts and Figures.

Job 14. Rear suspension and wheel bearings - replacement.

Carry out this Job in connection with illustration Job 1-1C and 1-1D.

• Step 1: IMPORTANT NOTE: The trailing arms come complete with bearings and spacers (arrowed) as an assembly. If the bearings are defective, or the arm is cracked or distorted, or showing signs of wear or corrosion on the wheel side, the whole assembly must be changed.

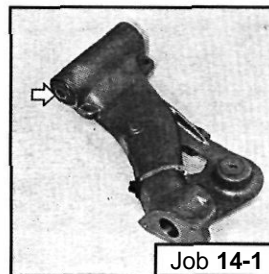

Job 14-1

Q Step 2: Support the rear of the car on axle stands so that the suspension hangs free. Remove the road wheels.

• Step 3: Remove the exhaust system. See PART F: FUEL AND EXHAUST, Job 14.

• Step 4: Remove the fuel tank. See PART F: FUEL AND EXHAUST, Job 10.

IG Step 5: Disconnect the brake pipes from the four-way union and plug the ends to prevent excessive fluid loss.

G Step 6: Slacken the cable adjustment under the handbrake lever and disconnect the rear cable ends from the equaliser. See PART H: BRAKES, Job 18.

making it easy! **Step 7:** • Using a trolley jack under the rear end of the trailing arm to be removed, compress the spring enough to undo the mounting nuts and remove the shock absorber.

• Slowly lower the jack and remove the spring. This allows you to use the weight of the car to help you compress the spring - a difficult task otherwise!

G Step 12: ...then complete the operation by using a standard puller with a strong packing piece (arrowed) for the puller shaft to 'push' against

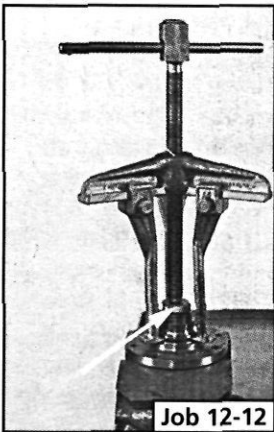

Job 12-12

G Step 13: Remove the circlip (see illustration Job 12-9, part b) and drift or press out the bearing outer track from the hub carrier.

• Step 14: Check the hub carrier for serviceability and replace if it is in any way damaged.

Q INSIDE INFORMATION! The new bearing is a complete sealed unit and requires no extra lubrication. **Q**

G Step 15: Press the bearing into the carrier using pressure on the outer track ONLY (a). Fit the circlip to retain it.

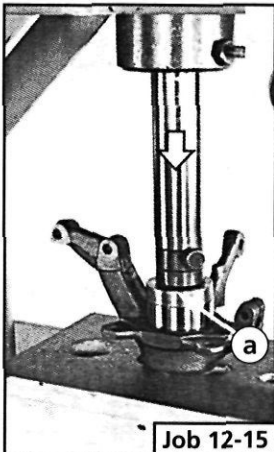

Job 12-15

• Step 16: Press the hub into the bearing, pushing ONLY on the inner track with a suitable piece of strong tube (1).

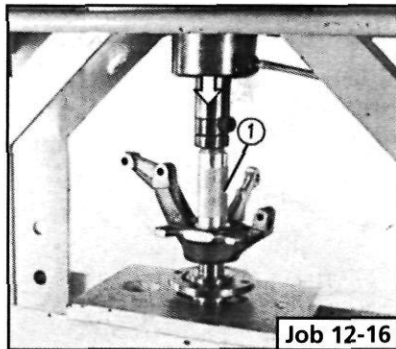

Job 12-16

LJ Step 17:

Reassemble the front suspension and brakes in the reverse order of removal. See relevant Jobs for detailed information. Use a NEW hub nut fitted as shown.

FACT FILE: STAKING THE HUB NUT

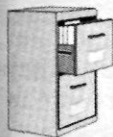

G Step 18: Use a cold chisel with an edge ground to an angle of about 60 degrees to stake the collar of the nut. USE A NEW NUT EACH TIME IT IS REPLACED.

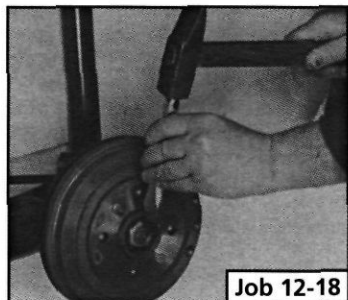

Job 12-18

G Step 19: Make sure the staked-down section of the collar fits in the stub axle slot in the opposite direction to the direction of the nut rotation, as shown.

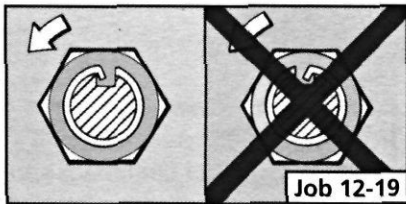

Job 12-19

LJ Step 8: Support the axle beam with the jack and undo the mounting bolts (arrowed and indicated by operator with socket bar). Lower the complete unit from the car.

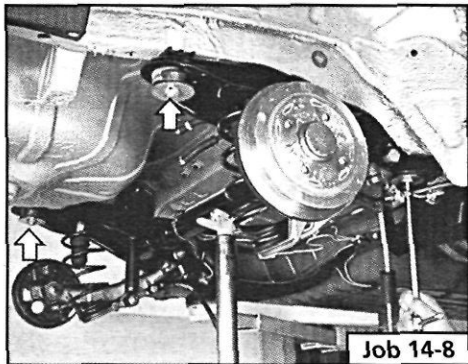

Job 14-8

IMPORTANT NOTE: In this shot, the top shock absorber mountings have been disconnected, leaving the shock absorber fitted to the suspension and the coil springs in place. We recommend 'our' approach, covered in **Step 7!**

Q Step 9: Undo the bolts securing the anti-roll bar and remove it. (See **Job 9.**) Disconnect the brake pipes from the side to be worked on and remove the brake drum.

Q Step 10: Remove the hub cap (see illustration **Job 1-W, part 13**) by carefully tapping and levering with a screwdriver.

Q Step 11: Undo the hub nut (see illustration **Job 1-1D, part 10**).

Q Step 12: A special tool (1857508000) or a VERY strong Allen key (a) will be required to reach into the hub (b), and plenty of leverage!

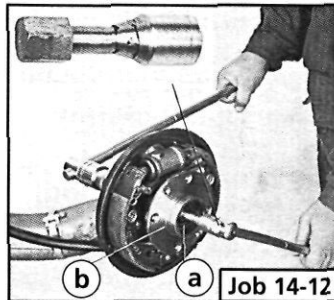

Job 14-12

Q Step 13: Remove the hub and inspect the bearing for roughness or noise or roughness when turning it by hand.

H INSIDE INFORMATION! The bearing is lubricated for life and is only supplied as an assembly with the hub. **Q**

QI Step 14: Inspect the stub axle pin (see illustration **Job 1-ID, part 12**) for any signs of damage or distortion. Replace if in doubt.

LJ Step 15: Refitting is the reverse of removal but note the following:

- See *Chapter 3, Facts and Figures* for all tightening torques as you progress through the assembling.
- Use new hub nuts and fully tighten once the suspension is mounted to give you stability.
- Refer to **PARTH: BRAKES** when refitting the brake parts and bleeding the brakes.

PART H: BRAKES

PART H: Contents

- Job 1.** Understanding Tipo/Temptra brakes.
- Job 2.** Front brake pads - replacement.
- Job 3.** Front brake caliper - replacement.
- Job 4.** Front brake disc - replacement.
- Job 5.** Rear brake shoes - replacement.
- Job 6.** Rear wheel cylinder - replacement.
- Job 7.** Rear brake disc pads - replacement.
- Job 8.** Rear brake caliper - replacement.
- Job 9.** Rear brake disc - replacement.
- Job 10.** Master cylinder - replacement.

- Job 11.** Servo check - remove and refit.
- Job 12.** Pressure regulating valve, non-ABS system - replacement and adjustment.
- Job 13.** Pressure regulating valves, ABS system - replacement and adjustment.
- Job 14.** RPM sensors, ABS systems - replacement.
- Job 15.** Flexible hoses - replacement.
- Job 16.** Metal pipes - replacement.
- Job 17.** Brake bleeding.
- Job 18.** Handbrake cables - replacement.

Job 1. Understanding Tipo/Temptra brakes.

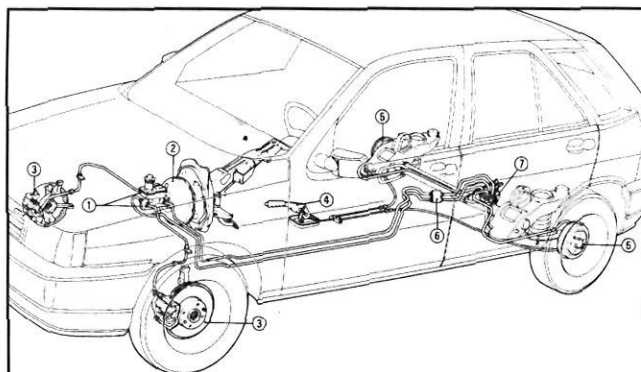

- 1 - fluid reservoir and master cylinder
- 2 - servo
- 3 - front disc brakes

- 4 - handbrake lever
- 5 - rear drum brakes
- 6 - four way pipe union
- 7 - load proportioning/pressure limiting valve

Job 1-1A

— Point 1A: This is the standard disc/drum system used on cars without anti-lock brakes, shown here in left hand drive form.

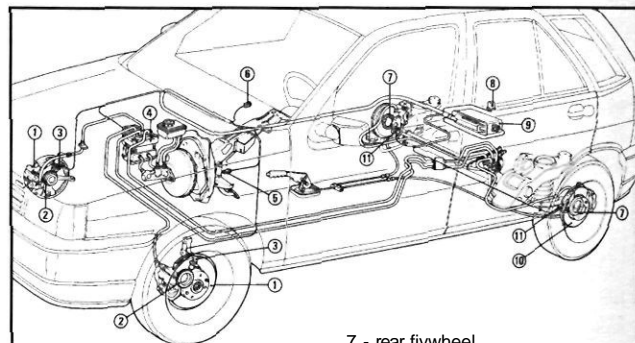

- 1 - front disc brakes
- 2 - front flywheel
- 3 - front wheel RPM sensors
- 4 - hydraulic control unit
- 5 - brake light switch
- 6 - device failure warning light switch

- 7 - rear flywheel
- 8 - main control relay with excess voltage protection
- 9 - electronic control unit
- 10 - rear disc brakes
- 11 - rear wheel RPM sensors
- 12 - load proportioning/pressure limiting valve

Job MB

D Point 1B: This version shows the anti-lock braking system and has discs replacing drums at the rear. One of two makes is used - Lucas or Bosch - and both are similar in design. Shown here is the Bosch ABS system in left hand drive form.

Apart from checking that the hydraulic and electrical connections are sound, anti-lock brakes are not repairable. Individual components and friction materials can be replaced but otherwise, you should consult your FIAT dealer for diagnosis of system faults (with specialised equipment) and rectification.

SPECIAL NOTES:

- Unplug the electronic control unit (ECU) before any electric welding is carried out.

- When oven drying paint, the ECU cannot withstand 95 degrees Celsius for more than a few minutes or 85 degrees Celsius for more than 2 hours.

- Disconnect the battery earth before removing the hydraulic control.

- When reconnecting the battery, make sure the connections are firm and sound.

Q INSIDE INFORMATION: When disconnecting brake pipes or hoses, it is essential to minimise brake fluid loss. This can be done by unscrewing the master cylinder reservoir cap, laying a sheet of plastic across the opening, and refitting the cap. This will prevent atmospheric pressure from pushing the fluid out of opened lines. **H**

Job 2. Front brake pads - replacement.

Changing and checking the Tipo's and Tempra's brake pads are virtually identical jobs. See *Chapter 5, Servicing Your Car, pages S9 and 60.*

Job 3. Front brake caliper - replacement.

Carry out this work with reference to *Chapter 5, Servicing Your Car, Job 49, pages 59 and 60.*

Q Step 1: Slacken the front road wheels, jack up the car and support on axle stands. Remove the wheels.

- **Step 2:** Unplug the brake pad wear sensor (a - arrowed) and ease the fluid pipe/hose from the bracket (b - arrowed) on the shock absorber leg.

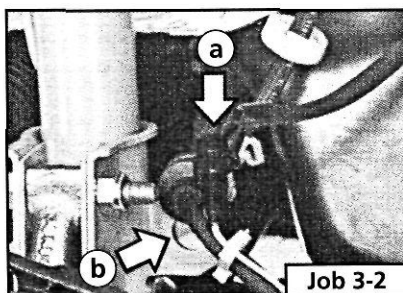

Q Step 3: Undo the brake fluid pipe union from the caliper body and plug the end to prevent too much fluid loss.

Q Step 4: Undo the bolts and remove the caliper.

B INSIDE INFORMATION! The caliper securing bolts must always be replaced by new FIAT ones when loosened or removed. They are of a special self-locking type. **Q**

H Step 5: Refit in reverse order and bleed the brakes, see *Job 17.*

Job 4. Front brake disc - replacement.

L1 Step 1: Carry out Steps 1 to 4 in Job 3.

- **Step 2:** Undo the securing bolts and remove the caliper support bracket.

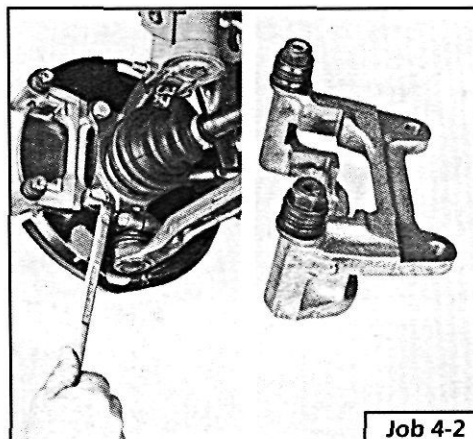

Q Step 3: Undo the disc fixing bolts and withdraw the brake disc.

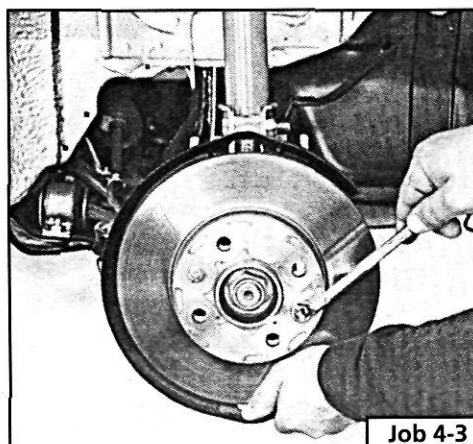

making it easy!

- Before refitting the disc, ensure that the mating surfaces - hub to disc, are clean and undamaged.

- Spin the disc to be sure there is no 'run out' before proceeding further.

Q Step 4: Refit the remaining parts in reverse order of removal. See *Chapter 5, Servicing Your Car.*

Carry out this work with reference to *Chapter 5, Servicing Your Car, Job 50, pages 60 and 61.*

Job 5. Rear brake shoes - replacement.

H INSIDE INFORMATION! It often helps to work on one side at a time, completing all the work on that side of the car and using the other side as a reference before you start dismantling it. **Q**

- 1 - brake shoe
- 2 - brake shoe lower return spring
- 3 - brake shoe retaining pin/collet
- 4 - self-adjusting device
- 5 - brake shoe upper return spring

The arrow shows the washer/dip which has to be replaced each time the brake shoes are replaced - although they are often ready-fitted to the complete shoe adjuster assembly.

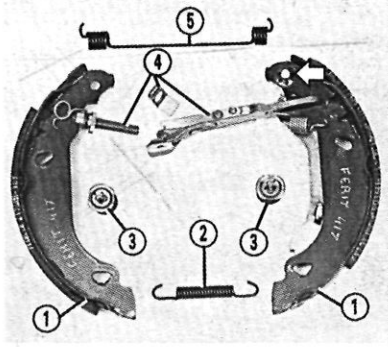

Job 5-1

Q Step 1: These are the brake shoe components and their relative positions.

Q Step 2: Remove the road wheel and brake drum, check the wheel cylinder and use aerosol brake cleaner. See **Chapter 5, Servicing Your Car, Job 50.**

Q Step 3: Lever out the cover from the backplate to expose the handbrake cable anchorage.



Job 5-3

• Step 4: THEORY! Using a combination of screwdriver and long nosed pliers, pull the cable nipple until it is clear of the step in the anchorage and then lift up the cable nipple, while taking the pressure off the spring and allow it to

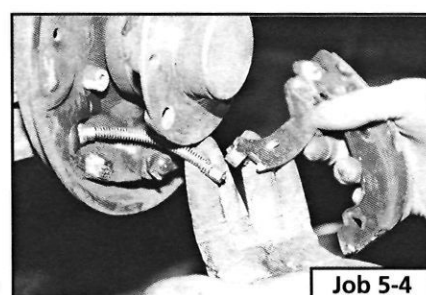

Job 5-4

making it easy! • In practice, **Step 4** can be quite a difficult task and some FIAT mechanics prefer to leave the cable disconnection until the brake shoes are clear of the backplate.

come clear.

• Step 5: Take the pressure off the lower spring before you try to remove it. Lever the shoe away from its lower mounting point (arrowed), pull it a little way forwards, so that it slides over the front of the mounting point and carefully release the tension.

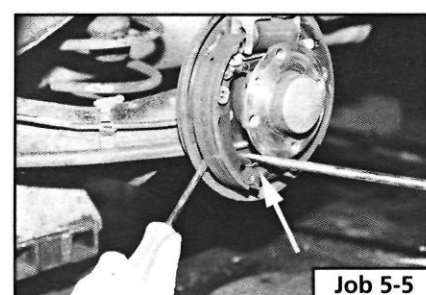

Job 5-5

Q Step 6: Unhook and remove the lower return spring...

• Step 7: ...and the self adjuster return spring followed by the upper return spring (arrowed).

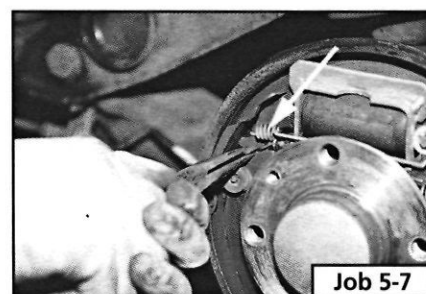

Job 5-7

• Step 8: Use a pair of pliers to push in and twist the spring caps off the shoe retaining pins.

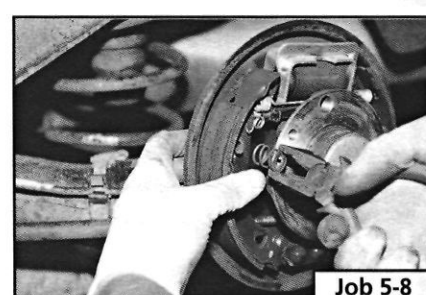

Job 5-8

C.) Step 9: Recover the caps and springs and withdraw the pins from the backplate.

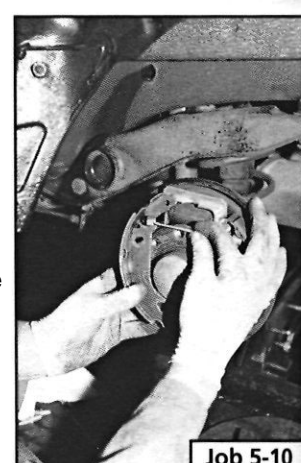

Job 5-10

LJ Step 10: Remove the brake shoes and retrieve the return springs.

[J Step 11: The rear shoe comes complete with the adjuster.

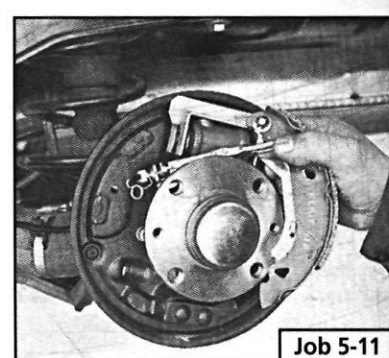

Job 5-11

Q Step 12: Release the self adjuster return spring from the brake shoe and separate.

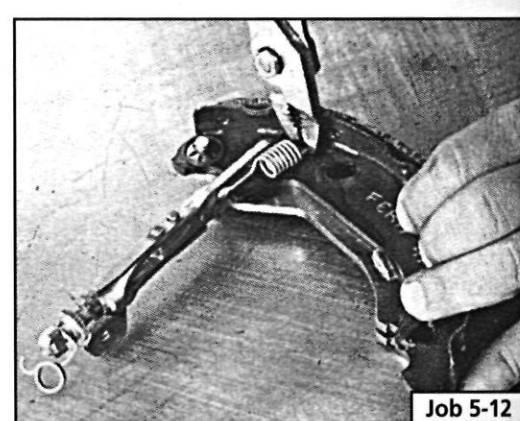

Job 5-12

• Step 13:

Clean the adjuster assembly and lubricate the adjustment screw (2) sparingly with copper grease. Before refitting, reset the adjuster by screwing the ratchet wheel (1) up to the spring (3) and then back off by half a turn.

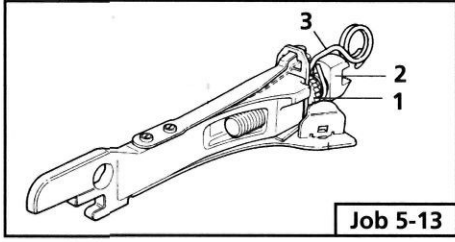

Job 5-13

Q Step 14: Smear a little brake grease (NOT ordinary grease) very sparingly on all the shoe contact points on the backplate and the springs, then continue to re-assemble in reverse order. Refer to Job 18 for handbrake cable adjustment.

• Step 15: Make absolutely certain that all of the springs are in good condition (replace any with stretched coils or straightened ends) and are fitted in their correct locations.

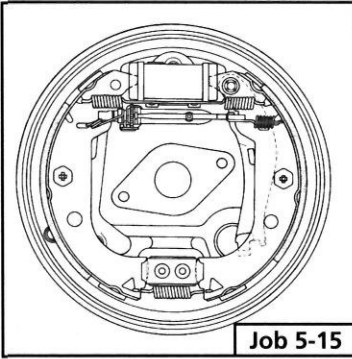

Job 5-15

Job 6. Rear wheel cylinder - replacement.

Q Step 1: Refer to Job 5 and remove the brake shoes.

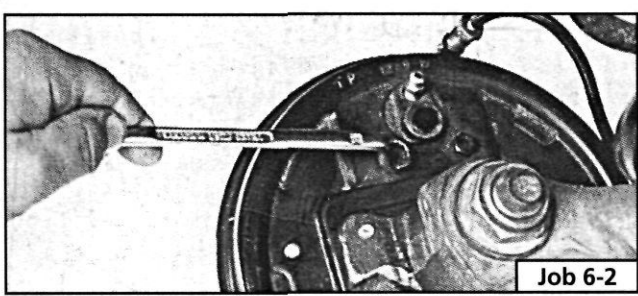

Job 6-2

Q Step 2: Undo the brake pipe union at the back of the wheel cylinder and plug the end (arrowed). Unscrew the two fixing bolts and withdraw the cylinder.

Q Step 3: Refit in the reverse order of removal. Refer to Job 17 for brake bleeding.

Job 7. Rear brake disc pads - replacement.

Changing and checking the Tipo's and Temptra's brake pads are virtually identical jobs. See Chapter 5, Servicing Your Car, pages 60 and 61.

Job 8. Rear brake caliper - replacement.

This job is carried out in the same way as pad replacement (Job 7) with the addition of the following:

• Step 1: Disconnect the handbrake cable (arrowed) and withdraw from the caliper body.

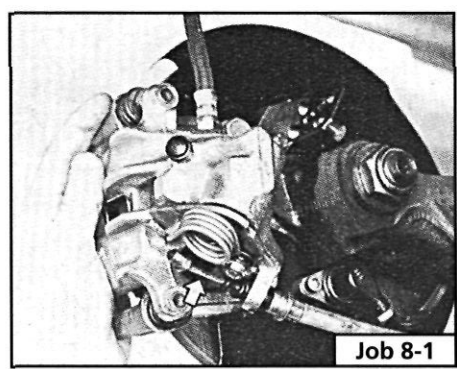

Job 8-1

Q Step 2: Slacken the brake hose at the caliper end, undo the caliper fixing bolts (arrowed), remove the caliper and unscrew the caliper and flexible hose from the end of the previously slackened rigid hose. Plug the hose ends.

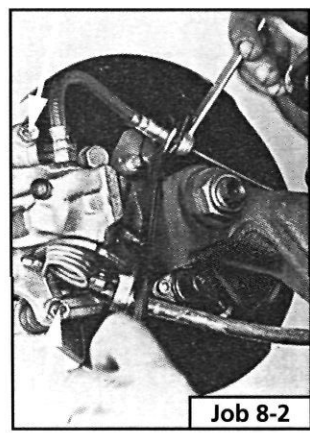

Job 8-2

LI Step 3: **Q INSIDE INFORMATION!** Before fitting the new caliper it must be primed with new brake fluid by connecting a tube to the opened bleed screw and pouring brake fluid through it until it comes out of the hole where the brake hose fits (arrowed). Then lock up the bleed nipple. **Q**

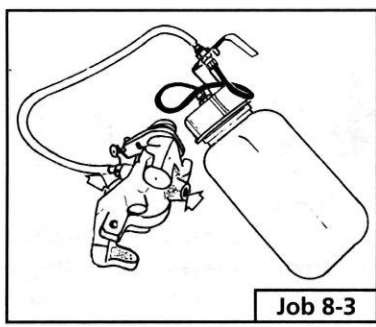

Job 8-3

Q Step 4: Refit the caliper using NEW self locking bolts. See Chapter 3, Facts and Figures.

LI Step 5: Complete this job as described in Chapter 5, Servicing Your Car, Job 59, page 61.

Job 9. Rear brake disc - replacement.

Q Step 1: Remove the brake pads and caliper as described in Job 7 and 8.

d Step 2: Undo the mounting bolts (arrowed)...

- **Step 3:** ...and remove the caliper support bracket.

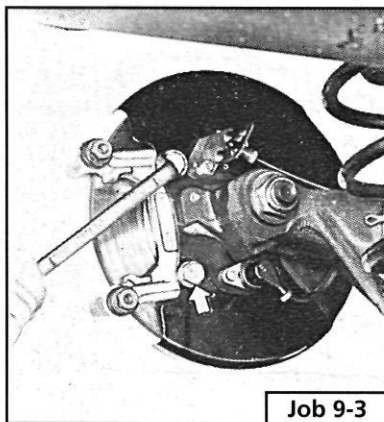

- U Step 4:** Unscrew the disc fixing bolts and withdraw the disc.

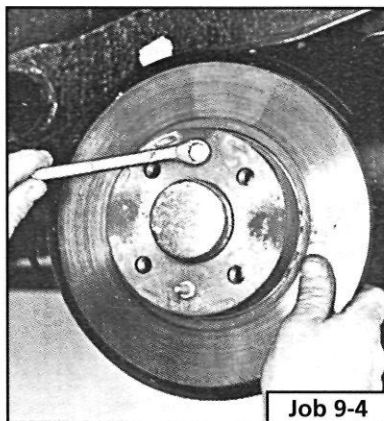

making it easy!

clean and undamaged.

- Before refitting the disc, ensure that the mating surfaces - hub to disc, are

Job 10. Master cylinder - replacement.

Q INSIDE INFORMATION: • On right-hand drive cars, the master cylinder is on the driver's side and is VERY different to get at, behind the engine.

• To remove the master cylinder on these cars you may need to remove the complete assembly - master cylinder, servo and pedal assembly - from inside the car. **Q**

- **Step 1:** IMPORTANT NOTE: Protect all paint surfaces from possible brake fluid spillage before starting work. You know what a good paint stripper it is!

LJ Step 2: Syphon off as much brake fluid as possible or bleed it out through one of the front brakes until the master cylinder makes 'sucking' noises.

- I Step 3:** Remove the reservoir from the master cylinder.

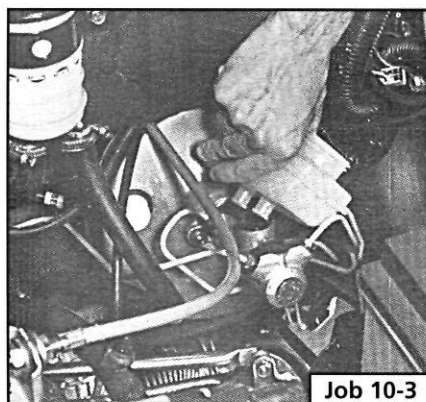

Q Step 4: Use a spanner - preferably a purpose-made split ring spanner - to undo all the pipe unions from the master cylinder.

- **Step 5:** Undo the nuts securing the master cylinder to the servo and remove it.

- **Step 6:** Refit in the reverse order and refer to **Job 17** for bleeding the brakes.

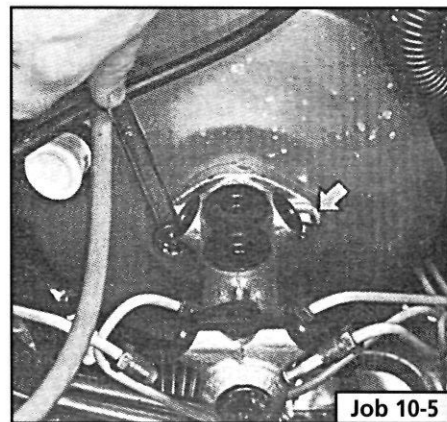

Job 11. Servo check - remove and refit.

H INSIDE INFORMATION: • Before condemning the servo for lack of efficiency, check the condition of the one-way valve and vacuum pipe connecting it to the inlet manifold.

- Ease the valve out of the front of the servo and disconnect the pipe from the inlet manifold.
- Check that you can only blow one way through the valve - from the servo end towards the inlet manifold (or the brake vacuum pump - Diesel models).
- The vacuum pipe can suffer failure in many ways. Age can harden it until it cracks, causing an air leak which sometimes results in a whistling noise and rough slow-running.
- Loose connections could also produce the same result.
- The other type of vacuum hose failure is an implosion (where the hose is sucked flat by the vacuum) often because oil has softened the hose.
- This is not so easily detected, as it rarely upsets the engine performance and resumes its normal shape shortly after the engine is stopped.
- The inner lining can also deteriorate, causing a blockage. **Q**

d Step 1: Follow **Job 10** to remove the master cylinder.

d Step 2: From inside the car, unhook the accelerator cable from the pedal fork.

- IJ Step 3:** Undo the fixing nuts, remove the retaining plate and pedal assembly.

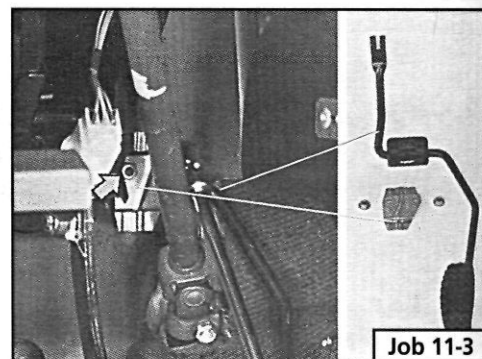

Job 12. Pressure regulating valve, non-ABS system - replacement and adjustment.

The pressure regulating valve is also known as the load proportioning valve.

LI Step 1: Position the car on ramps, over a pit or on a lift, keeping the weight on the rear wheels.

LJ Step 2: Remove the handbrake cable from its support bracket on the fuel tank...

U Step 3: ...and remove the support bracket for the rear exhaust section for better access.

• **Step 4:** Undo all the pipe unions on the regulating valve using split ring spanners where possible, to avoid damage. Plug the ends of the pipes and catch any fluid that drains out. Unhook the spring (arrowed) from the mounting bracket.

L Step 5: Undo the fixing belts and remove the valve assembly.

LJ Step 6: Mount the new unit, remake all hydraulic connections and connect the spring. Note that, if the valve does not work properly, it cannot be repaired but must be replaced.

L Step 7: Place a load of 60 kg with a full fuel tank, or 90 kg with an empty fuel tank, as far forward as possible in the boot.

J Step 8:

- Loosen the bracket retaining screw (1).
- Apply a downwards force to the bracket eye (2) of 55 Nm for all models except the 1600 automatic petrol and 1900 turbo diesel which should be 30 Nm.
- Keeping the bracket (3) in position. Tighten the retaining screw (1).

• **Step 9:** Bleed the brakes, see **Job 17**.

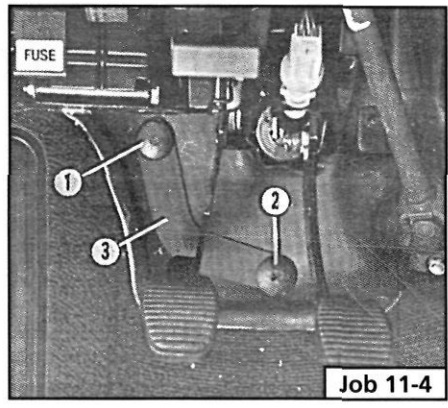

Job 11-4

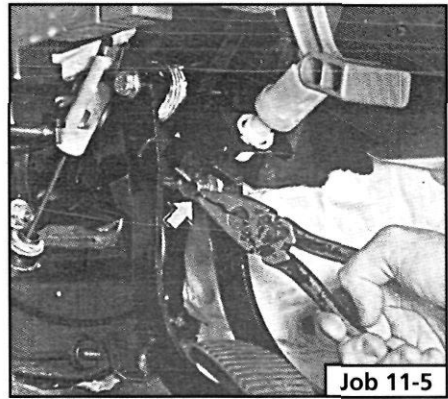

Job 11-5

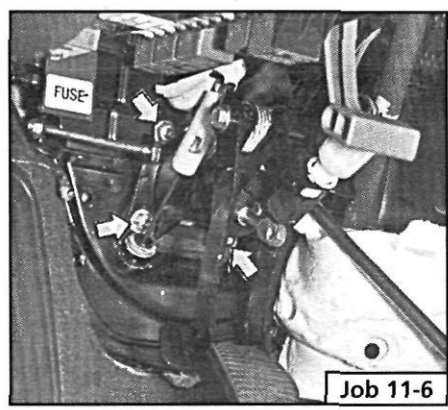

Job 11-6

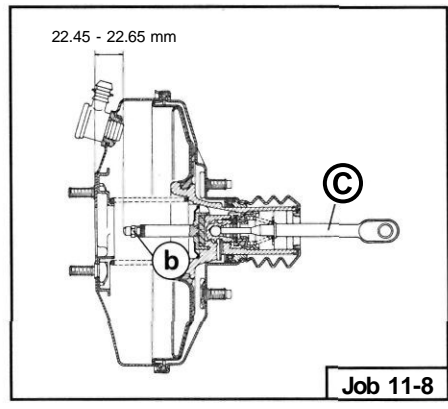

Job 11-8

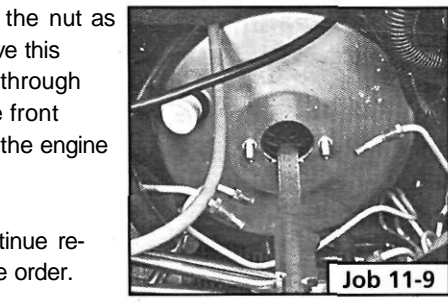

Job 11-9

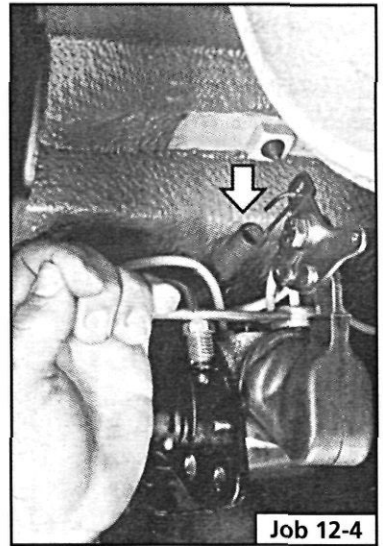

Job 12-4

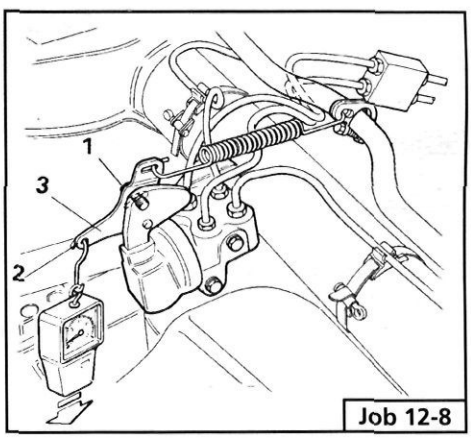

Job 12-8

G Step 4: Prise off the sound proofing plate stud with a screwdriver (1, which cannot be re-used) and unscrew the stud (2). Move the plate (3) to one side, to give access to the servo retaining nuts.

G Step 5: Remove the split pin and disconnect the servo rod from the brake pedal.

U Step 6: Move the sound proofing plate sufficiently to remove the servo mounting nuts (three-headed; one being unscrewed by a socket extension).

G Step 7: From under the bonnet, withdraw the servo from the bulkhead.

G Step 8: When refitting the servo to the bulkhead and with the pushrod (a) connected to the brake pedal, the gap between the piston control rod adjusting nut (b) and the master cylinder mounting flange should be between 22.45 and 22.65 mm.

• **Step 9:** Adjust the nut as necessary to achieve this setting measuring through the aperture in the front cover, from inside the engine bay.

G Step 10: Continue re-assembly in reverse order.

• 7. STEERING WHEEL

HEIGHT ADJUSTMENT

7. On some versions the height of the steering wheel can be adjusted - ONLY WITH VEHICLE STATIONARY!

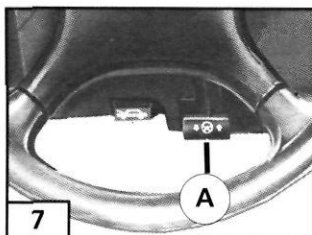

- Pull lever A, positioned under the steering wheel, towards you.
- When you have adjusted the wheel to a comfortable height push the lever back to its original position.

INDIVIDUAL SETTINGS

J 8. FRONT SEAT ADJUSTMENT

LEGROOM ADJUSTMENT

8A. Lift lever 1 and exert body pressure in the direction desired to set the seats fore-and-aft position:

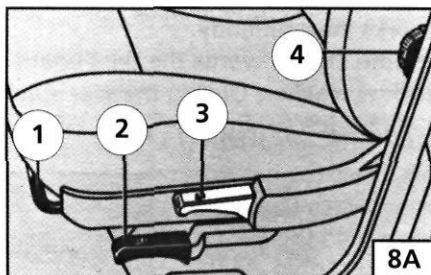

- Release lever 1, ensuring that the seat is locked in the desired position.

FRONT SEAT ANGLE ADJUSTMENT

To adjust the angle of the front seats backrest cushion:

- MODELS FITTED WITH A LEVER (ILLUSTRATION 8A, 3): lift to recline the seat.
- MODELS FITTED WITH AN ADJUSTABLE KNOB (8B, 4): rotate to recline the seat.

DRIVER'S SEAT HEIGHT ADJUSTMENT

On models with driver's seat height adjustment, depending on which type you have:

EITHER, pull up lever 2 (illustration 8A):

- Move forward to raise the seat.
- Move backward to lower the seat.

8C:»OR, pull lever 5 out so that it is at its full extension.

- Move lever 5 up or down to adjust the height of the seat.

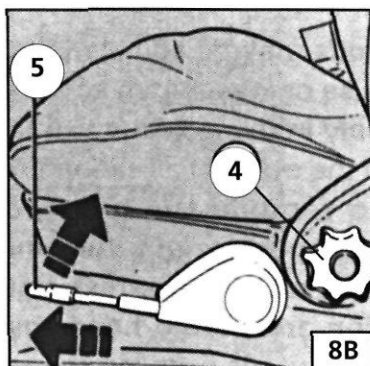

After the seat has been adjusted to the required height slide the extended lever back to its original collapsed position.

ACCESSORIES

J 9. DOOR MIRROR ADJUSTMENT

MANUAL TYPE

9A. Move the internal knob B (attached to the door mirror A) to adjust the mirror.

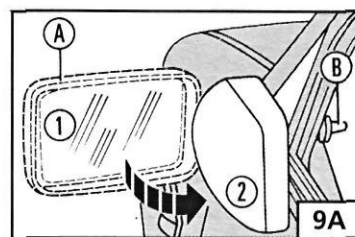

Move it from position 1 to position 2 from outside the car if extra clearance is needed.

POWER ADJUSTMENT

9B. When the key is at MAR, use the 4-way switch A (near the handbrake) to adjust the mirror and switch B to select left/right mirror.

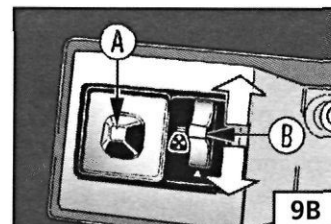

On some models mirrors are demisted/de-iced whenever you turn on the rear demister.

J 10. ELECTRIC WINDOWS

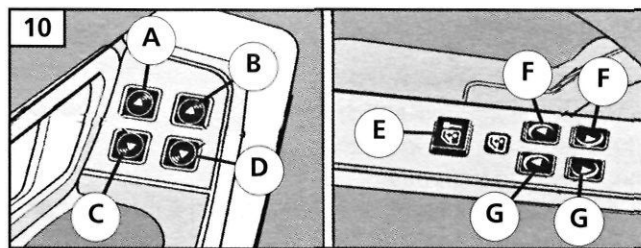

10. There are four buttons in the driver's armrest that operate the front electric windows (if fitted) when the key is at MAR:

- A - Closes left window.
- B - Closes right window.
- C - Opens left window.
- D - Opens right window.
- E - Locks and unlocks the rear electric windows.
- F and G - Open and close the rear side windows.

Some models are fitted with two buttons in the front passenger's armrest to open and close the passenger-side front window.

• 11. AIR BAG

AIR BAG SAFETY DEVICE

As an extra safety device, some models are fitted with an air bag, which is stored in the steering wheel. The air bag inflates immediately to protect the drivers chest and face in the event of a head on collision.

IMPORTANT NOTE: All diagnosis, repair and replacement of the air bag device is a specialist job and is potentially dangerous. It must only be carried out by your FIAT Service Centre.

Job 13. Pressure regulating valves, ABS system - replacement and adjustment.

O Step 1: Position the car over a pit or on a lift with the weight still on the wheels. Locate the valves - one on each suspension trailing arm.

• **Step 2:** Undo the brake pipe unions (a) using (preferably) a split ring spanner and plug the ends of the pipes. Remove the two upper securing bolts shown here

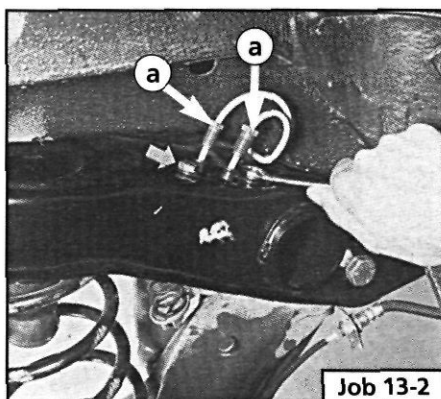

Job 13-2

• **Step 3:** Take out the lower two bolts and remove the valve.

• **Step 4:** Install the new valve and connect the brake pipes.

• **Step 5:** With the car at its normal weight including spare wheel and fuel, add a load of 50 kg to the boot as far forward as possible.



Job 13-3

• **Step 6:**
• Loosen the bracket fixing bolt (1).
• Hang a weight of 2 kg from the bracket eye (2).
• Keep the bracket in this position while you tighten and lock the fixing bolt (1).

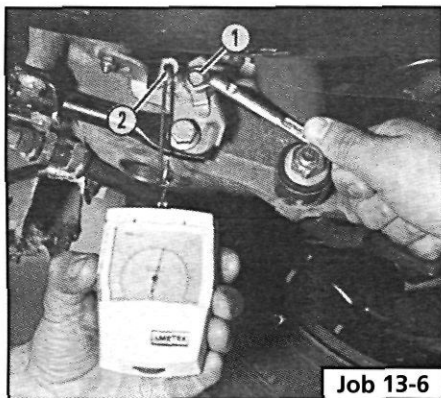

Job 13-6

LJ Step 7: Repeat this adjustment on the other side to ensure equal braking.

• **Step 8:** Bleed the brakes. See *Job 17*.

Job 14. RPM sensors, ABS systems - replacement.

Q INSIDE INFORMATION! The RPM sensors align with the flywheels (which look like toothed rings) and which rotate with the road wheels. The sensors measure the vehicle's running speed, acceleration, deceleration and wheel creep. These signals are sent to the electronic control unit and allow it to instruct the hydraulic control unit to vary the brake fluid pressure to each wheel as necessary to prevent the brakes from locking up. **Q**

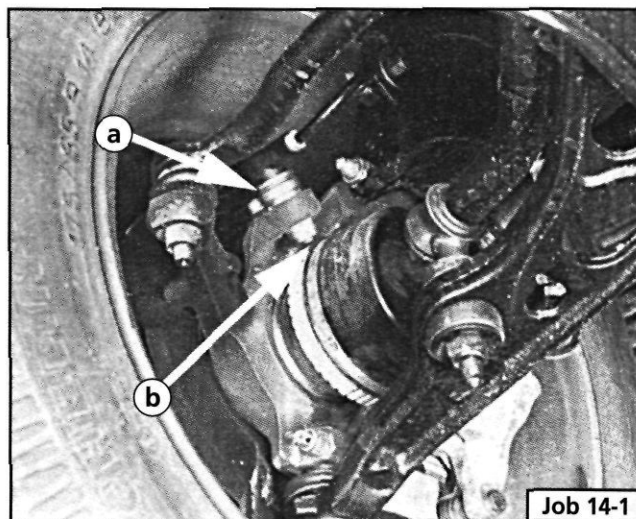

Job 14-1

• **Step 1:** This is the position of the front wheel sensor (a)...

U Step 2: ...and this is the position of the rear wheel sensor (arrowed).

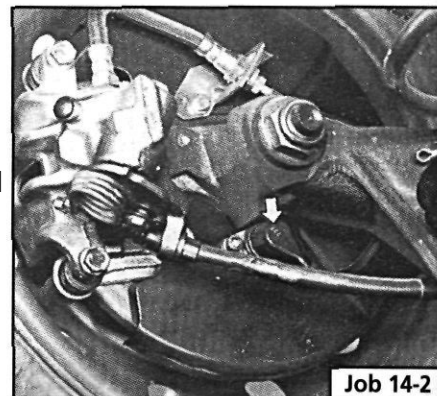

Job 14-2

IJ Step 3:

Check the gap between the end of each sensor and the flywheel, at the front (see illustration *Job 14-1, part b*) and at the rear. The correct gap should be:

- 1400/1600 petrol - between 0.62 and 1.35 mm, both front and rear.
- 1900 turbo Diesel - between 0.225 and 0.925 mm for the fronts and between 0.13 and 1.27 mm for the rears.

H INSIDE INFORMATION! FIAT advise that no adjustments can be made, so, if the gap is outside these values, clean and check the condition and the seating of the sensor and the condition of the flywheel. **Q**

LJ Step 4: To remove the sensor, undo the fixing screw and withdraw the sensor from its housing, then trace the wire to the connector and unplug it.

LJ Step 5: Clean round the housing and fit the new sensor, ensuring that it is properly seated.

C) Step 6: Secure the wire along its route to the connector and plug in.

Job 15. Flexible hoses - replacement.

INSIDE INFORMATION: When disconnecting brake pipes or hoses, it is helpful to minimise brake fluid loss. This can be done by unscrewing the master cylinder reservoir cap, laying a sheet of plastic across the opening, and refitting the cap. This will prevent atmospheric pressure from pushing the fluid out of opened lines. **Q**

LJ Step 1: Undo the front hose rigid pipe union (see illustration *Job 15-2, part a*) where hose and pipe join at the support bracket. Use the spanner underneath the bracket to stop the hose twisting. Take care not to damage the bracket or tear it off the body.

Step 2: Pull out the clip (b).

LJ Step 3: Unplug the electrical connection for the brake pad wear sensor and unclip it from the hose.

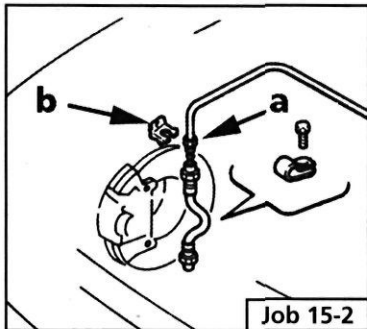

LJ Step 4: Unscrew and remove the hose from its other end - it screws into a female thread.

Step 5: Refit in reverse order and position the washers and the position of the hose at the anchorage point (A) as shown, so as to prevent chafing

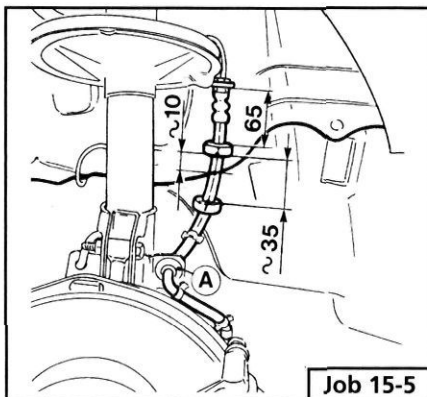

on the body when suspension and steering movement take place. When tightening each union, make sure you haven't put a twist in the hose!

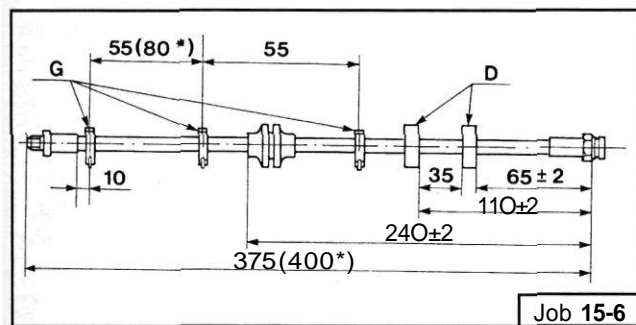

LJ Step 6: These are the correct positions of clips and protective washers on the hose. Figures with a * are for 1929 turbo Diesel only.

Step 7: **Q INSIDE INFORMATION!** Changing the rear hoses is the same, but there are no electrical cables or protective washers. **Q**

U Step 8: Bleed the brakes, see *Job 17*.

making it easy!

- If a rigid pipe starts to twist with the union, grip the pipe as lightly as possible, and see if you can stop it from turning.
- If not, cut through the pipe with a junior hacksaw and replace the length of rigid pipe.

Job 16. Metal pipes - replacement.

Q INSIDE INFORMATION: When disconnecting brake pipes or hoses, it is helpful to minimise brake fluid loss. This can be done by unscrewing the master cylinder reservoir cap, laying a sheet of plastic across the opening, and refitting the cap. This will prevent atmospheric pressure from pushing the fluid out of opened lines. A pipe spanner makes the job *much* easier! **fl**

LJ Step 1: Undo the unions at each end of a pipe length. Patience is often required because of the union seizing both in its threads and on the pipe. See **MAKING IT EASY!** after *Job 15, Step 8*. Use penetrating oil to help free seized unions, and use a split-ring spanner rather than an open-ended one, to reduce the risk of rounding off the union nuts.

LJ Step 2: Detach the pipe length from its securing clips and remove it.

making it easy!

- **LJ Step 3:** Where possible, use the old pipe as a pattern to shape the new one prior to fitting.

LJ Step 4: Follow the original route and secure the pipe in the body clips.

LJ Step 5: Connect the unions and bleed the system. See *Job 17*.

Job 17. Brake bleeding.

D INSIDE INFORMATION: Unless the master cylinder or pressure regulating valve has been disturbed, it will only be necessary to bleed the end of the braking system which has been opened. If bleeding the whole system, start bleeding at the left-hand rear brake. **B**

making it easy!

- When bleeding the rear brakes, keep the normal weight on the rear wheels to prevent the pressure limiting valve from inhibiting the brake fluid flow.

J Step 1:

Push a tight fitting length of plastic or rubber tubing (a) onto the first bleed screw (b) and immerse the other end in a small quantity of brake fluid (c) contained in a glass jar in such a way that no air can accidentally be pulled up the tube.

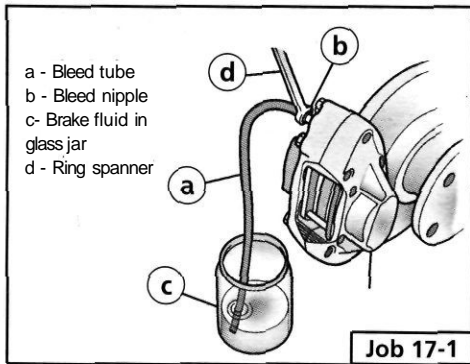

Job 17-1

LJ Step 2: With a ring spanner (illustrations Job 17-1, part, d), undo the brake bleed screw (at the drum brake backplate or on the disc caliper body) by half a turn. Have your helper push the brake pedal to the floor and hold it there while you lock up the bleed valve. Then release the pedal slowly. Repeat several times, with the following suggested dialogue:

YOU. (Open bleed screw) "Open!" {called out loud}

HELPER. (Pushes pedal down) "Down!"

YOU. (Close bleed screw) "Closed!"

HELPER. (Lets pedal up) "Up!" - repeated, as necessary.

IMPORTANT NOTE: Take great care not to let the master cylinder run out of brake fluid. Otherwise you will introduce fresh air into the system and have to start again. Use ONLY fresh brake fluid from a previously unopened container.

LJ Step 3: Top up the fluid reservoir frequently while repeating the bleeding operation until all air is expelled from the brake line (no bubbles appear in the tube or jar).

LJ Step 4: Bleed each remaining brake in the same way, going to the right-hand front next, followed by the right-hand rear, and finishing with the left-hand front brake. Top up fluid and check all connections for leaks.

Job 18. Handbrake cables - replacement.

[J Step 1: Familiarise yourself with the handbrake cable layout. The following instructions refer to this drawing.

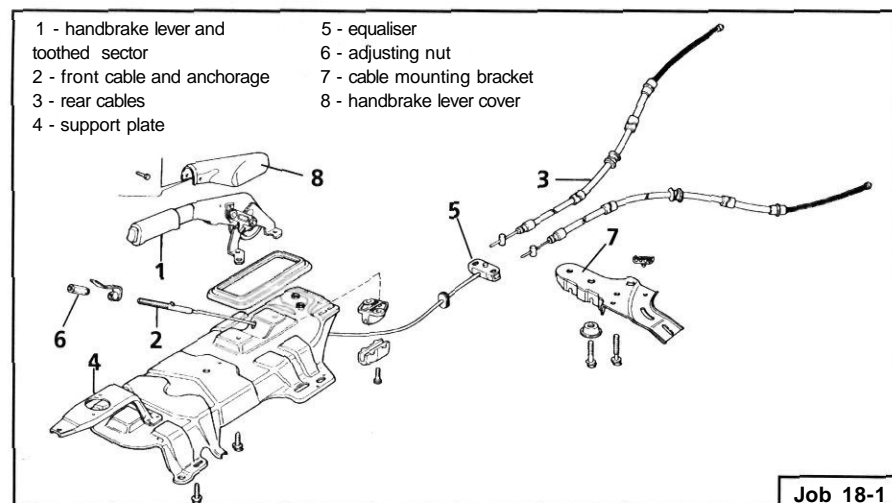

Job 18-1

FRONT CABLE

LJ Step 2: Jack up and support the rear of the car on axle stands.

LJ Step 3: From inside the car, remove the handbrake lever cover by undoing the single fixing screw and fully release the handbrake.

LJ Step 4: Unscrew the adjusting nut from the end of the cable. You will find it underneath the base of the handbrake lever.

LJ Step 5: From under the car, release the front ends of the rear cables from the equaliser, then pull the front cable through the floor aperture.

LJ Step 6: Refit in the reverse order and adjust the cable nut until the lever travels no more than three notches on the ratchet when you pull the brake on, and when released, the wheels still revolve freely.

REAR CABLES

LJ Step 7: Carry out Steps 1 to 3.

LJ Step 8: Unscrew the adjusting nut to the end of its thread.

LJ Step 9: Unhook the front of the rear cables from the equaliser. See Step 5.

LJ Step 10: In the case of rear drum brakes, detach the cables from the brakes as described in Job 5, Steps 3 and 4.

LJ Step 11: In the case of disc rear brakes, see Job 8, Step 1.

LJ Step 12: Re-assemble in reverse order.

J Step 13: Adjust the handbrake cable until the lever comes up no more than three notches and when released, allows both of the rear wheels to revolve freely. Try spinning them by hand with rear of the car raised off the ground.

PART I: Contents

- Job 1.** Bonnet • removal and refitting.
- Job 2.** Bonnet locking mechanism - replacement and adjustment.
- Job 3.** Radiator grille - removal and refitting.
- Job 4.** Tipo/Tempra tailgate - removal and refitting.
- Job 5.** Tipo tailgate locking mechanism - removal and refitting.
- Job 6.** Tempra estate tailgate locking mechanism - removal and refitting.
- Job 7.** Tempra boot lid - removal and refitting.

- Job 8.** Tempra boot lid locking mechanism - removal and refitting.
- Job 9.** Front bumper and grille - removal and refitting.
- Job 10.** Rear bumper - removal and refitting.
- Job 11.** Door trim panel - removal and refitting.
- Job 12.** Door component - removal and replacement
- Job 13.** Door removal, replacement and adjustment.
- Job 14.** Door mirror - replacement.
- Job 15.** Sun roof - removal and refitting.
- Job 16.** Front seats - removal and refitting.
- Job 17.** Rear seats - removal and refitting.

Job 1. Bonnet - removal and refitting.

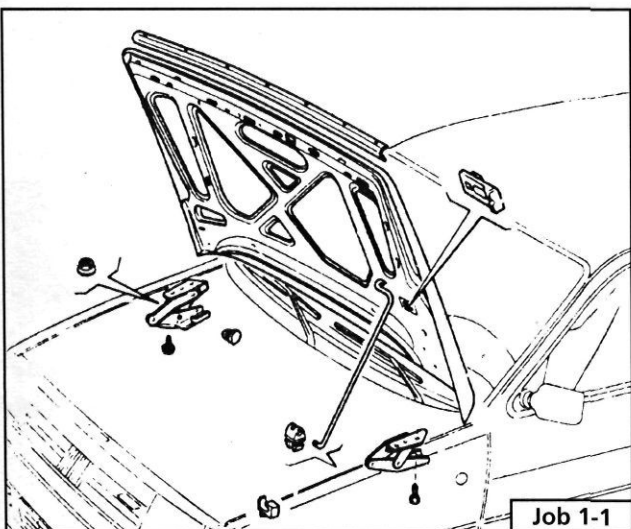

Job 1-1

Job 2. Bonnet locking mechanism - replacement and adjustment.

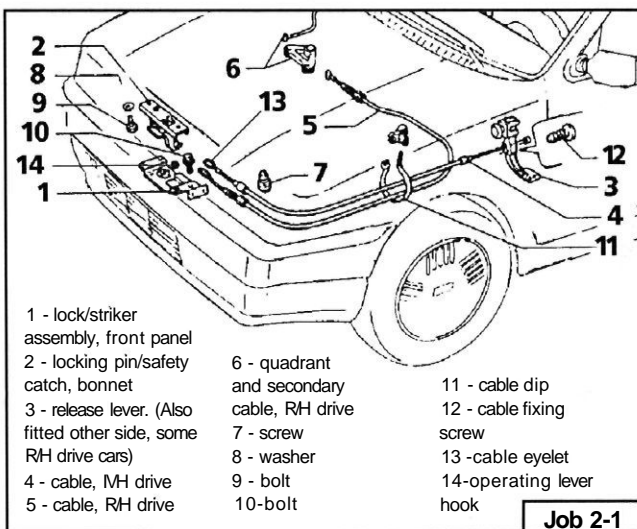

Job 2-1

Q Step 1: Note the bonnet hinges, support and stops.

LJ Step 2: Use the prop and hold the bonnet open. Outline the hinge positions on the bonnet with masking tape for accurate refitment.

U Step 3: Ask an assistant to support the bonnet. Undo the two hinge fixing bolts. Carefully lift the bonnet clear.

making it easy!

O Step 4: • Before refitting the bonnet, put a piece of cloth under each rear corner to protect the bodywork.

Q Step 5: When refitting, tighten the bolts just enough to grip the hinges, then carefully lower the bonnet to check for correct alignment all round - equal gapping.

When the alignment is satisfactory, tighten the bolts to their correct torque, See **Chapter 3, Facts and Figures.**

d Step 1: This drawing shows left and right hand drive layouts. Select which is right for your car.

Q Step 2: The two screws (illustration **Job 2-3** arrowed) used to fix the locking pin/safety catch assembly to the bonnet are also used for fore and aft adjustment. This is best done a little at a time until smooth operation is achieved.

LJ Step 3: Height adjustment (levelling with the wings) is achieved by screwing the bump stops (inset, arrowed) up or down. Then slacken the locking nut (hidden behind the locking pin spring) and screw the locking pin up or down until the bonnet will shut when dropped from 30 cm height and then have no movement on the lock. Don't forget to tighten the locknut.

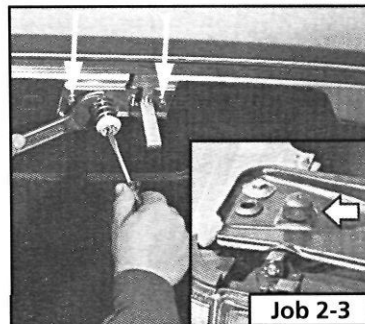

Job 2-3

d Step 4: To remove the lock/striker assembly, separate the cable eyelet from the operating lever hook, see illustration **Job 2-1, parts 13** and **14.**

Step 5: Undo the securing bolts (see illustration *Job 2-1, part 10*) and remove the lock.

LJ Step 6: Refit in reverse order.

LJ Step 7: Replace a cable by disconnecting it at each end and releasing it from any securing clips. Run the new cable along the same route and re-connect and secure.

Job 3. Radiator grille - removal and refitting.

Step 1: Undo the two fixing screws (arrowed)...



LJ Step 2: ...and pull out at the top of the grille to release it from the securing clips. Withdraw the grille.

Step 3: Refit in reverse order.

Job 4. Tipo/Tempra tailgate - removal and refitting.

J Step 1:

Disconnect the battery negative terminal.

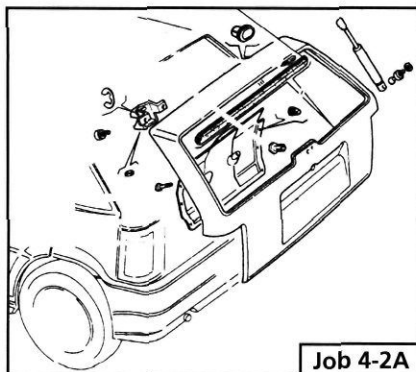

Step 2A: Take note of this exploded view of the Tipo tailgate.

Step 2B: This is the Tempra estate layout.

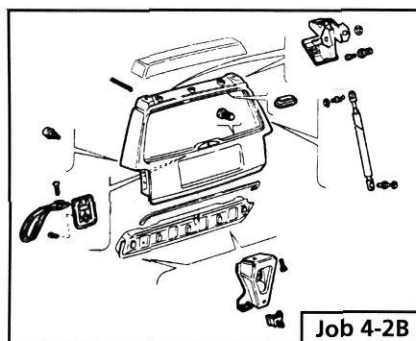

IMPORTANT NOTE: While these instructions are for the Tipo, the Tempra estate is very similar.

Step 3: Disconnect all the electrical connections and the washer tubing.

LJ Step 4: Remove the left cable duct (left-side) and withdraw the cables from the body shell. Its 'twin', on the other side, is a plain stop. See *Step 8*.

LJ Step 5: Support the weight of the tailgate with a suitable length of timber and protective pad.

Step 6: TIPO ONLY: Remove the semi-circular safety spring from the gas strut balljoints and pull the socket off the ball.

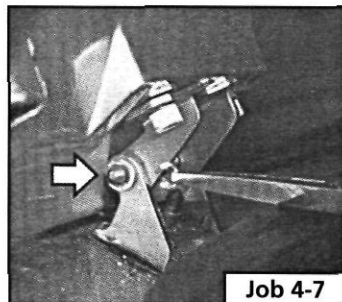

TEMPRA SW ONLY: Unbolt the tailgate from the hinges.

LJ Step 7: Extract the circlips retaining the hinge pins with pliers. Support the forward end of the tailgate and knock out the hinge pins (arrowed), and remove the tailgate.

WARNING! At all costs, avoid loosening the Tipo's hinge bolts on the body or tailgate - or they will have to be replaced, according to FIAT.

Step 8: Q INSIDE INFORMATION! When removing and when refitting, particular attention must be paid when inserting the stop engagement teeth to avoid breaking and replacing the stops.
To refit, insert the upper tooth, then turn the stop downwards and insert the lower tooth. B

LJ Step 9: Continue to re-assemble in reverse order.

Job 5. Tipo tailgate locking mechanism - removal and refitting.

LJ Step 1:

Study this exploded view of the locking mechanism to help you understand the job.

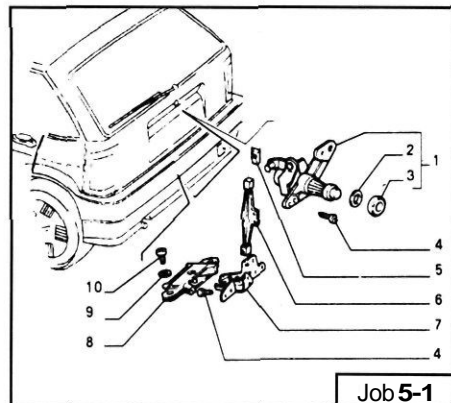

Step 2: Remove the five bolts (a) securing the lock assembly...

[J Step 3: ...and carefully lever off the five buttons (see illustration *Job 5-2, arrowed*). The lock assembly (fitted to the inside of the cover) is now free.

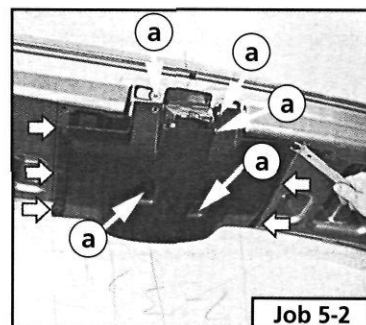

LJ Step 4: Unplug the lock servo control connector from inside the cover and remove the lock assembly from the car.

LJ Step 5: Disconnect the control rod (see illustration *Job 5-1, part 6*) and remove the speed fasteners (*Job 5-1, part 5*).

LJ Step 6: Remove the two screws (illustration *Job 5-1, parts 4, 9 and JO*) and the closing device (*Job 5-1, part 7*).

LJ Step 7: Remove the sealing ring (illustration *Job 5-1, part 2*) from the locking barrel and detach the two retaining springs. Remove the locking barrel.

LJ Step 9: The magnetic locking device (illustration *Job 5-7, part 8*) is removed by undoing the two retaining screws.

LJ Step 10: Refitting is the reverse of removal.

Job 6. Tempra estate tailgate locking mechanism - removal and refitting.

LJ Step 1: Remove the trim to expose the mechanism.

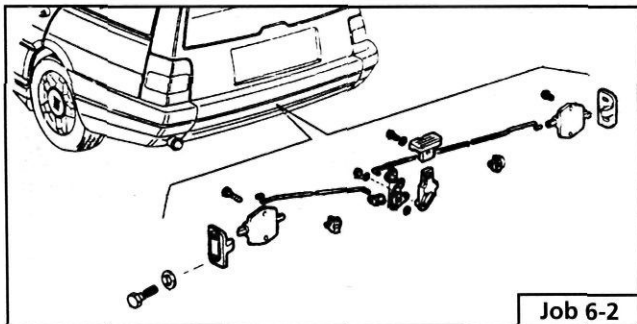

LJ Step 2: The mechanism is a simple lever and rod system and is dismantled by removing the outer bolt fixings, followed by the inner lever-end fixings.

Job 7. Tempra boot lid - removal and refitting.

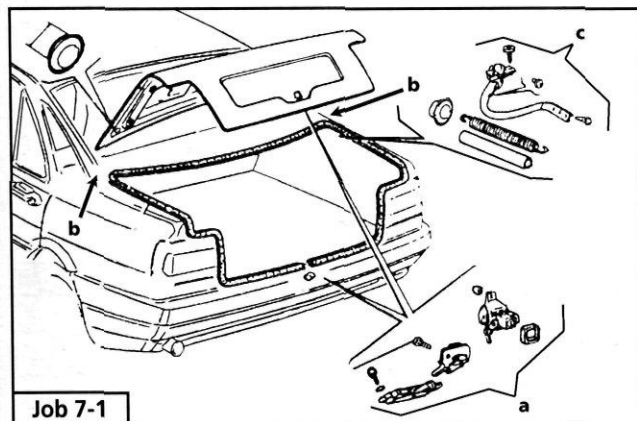

LJ Step 1: These are the boot lid components in exploded form. Remove the boot interior trim panel and disconnect the wires serving the door lock motor (a).

LJ Step 2: Carefully prise out the number plate lights and disconnect them. Put the cables back inside the double skin.

LJ Step 3: Withdraw the cables through the hole by the left hinge.

LJ Step 4: Put some protective rag on the body, under the sharp corners of the lid. (See illustration *Job 7-1, part b.*) Use masking tape to outline the hinge positions on the lid and assist in re-alignment.

LJ Step 5: Ask an assistant to help support the lid, then undo the hinge screws, disconnect each hinge assembly (c) and remove the lid.

LJ Step 6: Refit in reverse order.

Job 8. Tempra boot lid locking mechanism - removal and refitting.

LJ Step 1: Refer to the drawing in *Job 7, Step 1.*

LJ Step 2: Remove the interior trim panel for access.

LJ Step 3: Unplug the electrical connection from the boot lid catch. Undo the two securing screws and remove the catch.

LJ Step 4: To remove the central locking servo, unplug the electrical connection, then undo the two mounting screws and remove the servo.

Q INSIDE INFORMATION! To remove the lock, (which operates the catch referred to in **Step 3**) you must first remove the number plate holder. **H**

LJ Step 5: Remove the number plate lights by easing them out of their mounting holes and disconnect the electrical plugs.

Q Step 6: Use a hair dryer and, working from inside the boot, heat the number plate holder perimeter.

IMPORTANT NOTE: Your hairdryer might not get hot enough; or it (or a hot air blower) might get too hot and damage the paintwork. You are recommended to leave this part of the job to your FIAT dealer, or to proceed with enormous care.

LJ Step 7: Release the four clips and push out the number plate holder/lock assembly.

LJ Step 8: Undo the three nuts and remove the lock.

LJ Step 9: Carefully remove the old sealant from both surfaces and clean thoroughly with a suitable solvent.

LJ Step 10: Mount the new lock on the number plate holder and apply a suitable silicone sealer approximately 8 mm high in a continuous seam round the perimeter. Level the sealant if necessary.

LJ Step 11: Position the number plate holder in the boot lid hole.

H INSIDE INFORMATION! This is made easier by pressing out the retaining clips from inside the boot. The positioning must be completed within 5 minutes of applying the sealant. Hold the number plate holder in position with masking tape on the outside and leave to set for at least 3 hours without any disturbance. **Q**

LJ Step 12: Now the remaining parts can be fitted in reverse order.

Job 9. Front bumper - removal and refitting.

Q INSIDE INFORMATION! The method of removal is the same for Tipo and Tempra. Some models with higher trim levels have decorative bumper inserts. **O**

• **Step 1:**
Remove the grille. See Job 3,

• **Step 2:**
Remove the four lower fixing bolts (ax2 and bx2)...

U Step 3:
...and the buttons (illustration Job 9-2, part e) that fix the bumper to the wheel arch liner.

Q Step 4: Undo the two top fixing bolts (illustration Job 9-2, parts c) and remove the bumper by sliding/pulling it forwards.

CD Step 5: Refit in the reverse order, but make sure that the side fixing blocks (illustrations Job 9-1, part d) on the body engages properly with the guides (Job 9-1, part e) on the bumper.

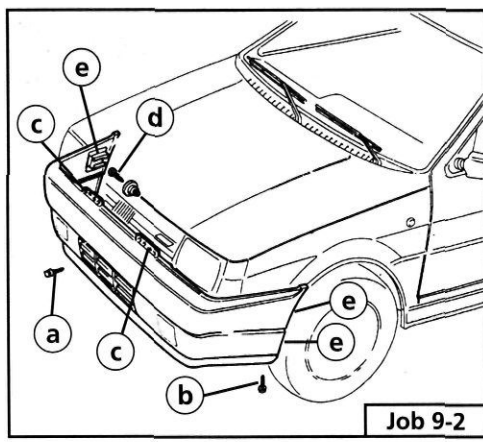

Job 9-2

Job 10. Rear bumper - removal and refitting.

J Step 1A:
B INSIDE INFORMATION! The method of removal and refitting is the same for all variants. The Tempra estate has a three section bumper which once removed, can be split to replace individual parts as shown in this drawing. **Q**

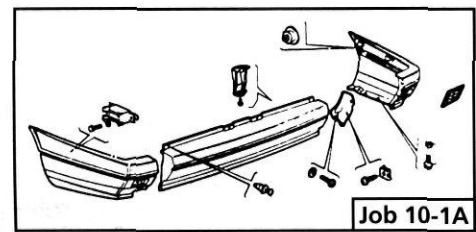

Job 10-1A

• **Step 1B:**
Some models, such as this Tipo, with higher trim levels have decorative bumper inserts but otherwise, removal is the same.

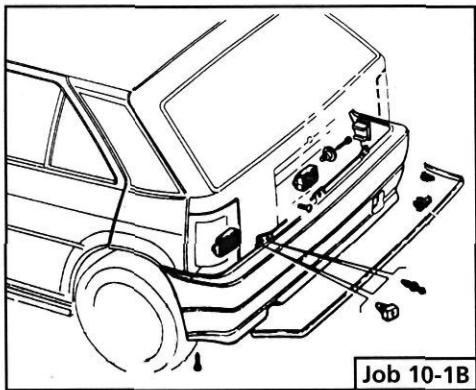

Job 10-1B

• **Step 1C:**
The Tempra saloon has slightly different fixing positions.

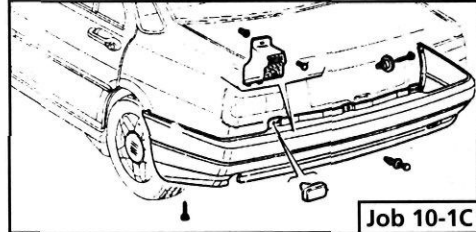

Job 10-1C

• **Step 2:**
Open the tailgate or boot lid and remove the upper fixing bolts.

Q Step 3: Remove the rear wheel arch liners by undoing the fixing bolts and buttons.

Q Step 4: Undo the bumper fixing bolts (see illustrations Steps 1A, 1B and 1Q) and withdraw the bumper from the car.

d Step 5: Refit in the reverse order, but make sure that the side fixing blocks on the body engage properly with the guides on the bumper. The bumper slides on/slides off.

Job 11. Door trim panels - removal and refitting.

IMPORTANT NOTE 1: All of the illustration references in this job relate to illustration Job 11-A1 and illustration Job 11-B1.

IMPORTANT NOTE 2: Identify the trim panels fitted to your car. One piece trim panels (Type A) are the early type; two piece trim panels (Type B) are the later type.

TYPE A: EARLY TRIM PANELS

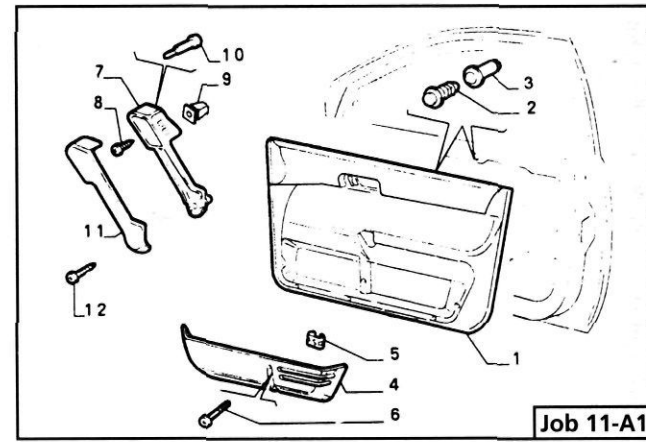

Job 11-A1

FRONT DOORS

Q Step A1: Remove the interior door handle trim (11) by removing the outer screw (12).

• **Step A2:** Undo the inner fixing screw (see illustration Job 11-A1, parts) and withdraw the handle far enough to....

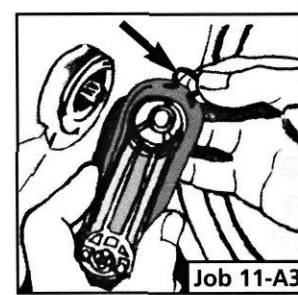

Job 11-A3

Q Step A3: unplug the window's electrical connector, where fitted.

H INSIDE INFORMATION! If the window or regulator is being removed, lower the glass before undoing the plug. Where manually operated windows are fitted, remove the window regulator handle by hooking out the horse shoe type retaining clip (arrowed) from behind it. **D**

LJ Step A4:
Carefully prise out the escutcheon plate and twist it in the direction shown by the arrow to allow it to be withdrawn over the opening lever and removed.

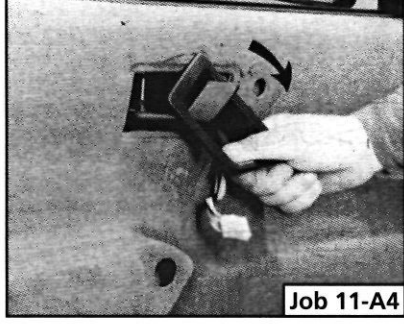

• **Step A5:**
Unscrew the six screws (illustration Job 11-A1, part 6) and remove the door pocket (Job 11-A1, part 4).

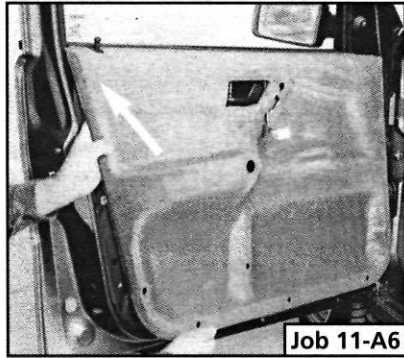

• **Step A6:**
Unscrew and remove the internal locking button (arrowed) and remove the trim panel by carefully levering out the door retaining studs with a flat bladed tool (preferably two-pronged) to fit either side of the shoulder of part 2, part 3 remaining in the door frame. Care is needed here to locate each retaining stud and avoid damage when disconnecting part 2 from part 3.

Q INSIDE INFORMATION! Avoid pulling the door trim off with your hands and tearing the trim next to the studs. **Q**

d Step A7: Refit in the reverse order of removal, banging each retaining stud carefully home with the flat of your hand.

REAR DOORS

Q Step A8: Follow the instructions for the front door, but ignore those for the door pocket and window switch.

TYPE B: LATER TRIM PANELS.

FRONT DOORS

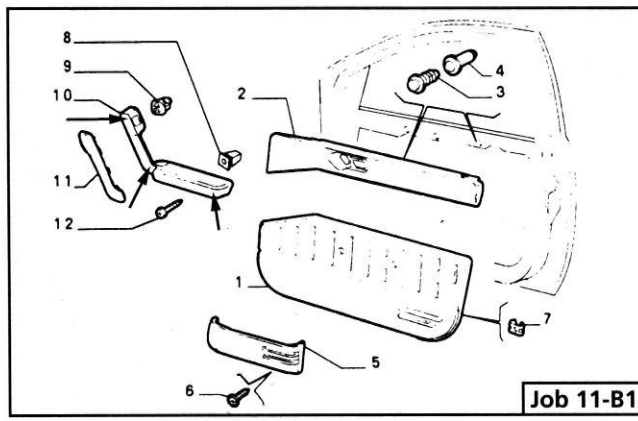

Q Step B1: Undo the four screws (6) and remove the door pocket (5).

Step B2: Carefully lever off the door handle trim (see illustration Job 11-B1, part 11).

Q Step B3: Undo the three screws (11-B1, part 12 - positions arrowed) and withdraw the handle (11-B1, part 10) enough to....

• **Step B4:**
...disconnect the electric windows control where fitted (arrowed).



• **Step B5:**
Carefully prise out the escutcheon plate (see illustration Job 11-A4) and twist it in the direction shown by the arrow to allow it to be withdrawn over the opening lever and removed.

Q Step B6: Remove the door trim as described in Step A6 and Step A7, removing the upper trim (Job 11-B1, part 2) in a similar way.

REAR DOORS

Q Step B7: Follow the instructions for the front door, but ignore those for the door pocket and window switch.

Job 12. Door components, removal and replacement.

Q INSIDE INFORMATION! There are two types of door shell. The early type has a subframe behind the trim panel which can be removed complete with the window regulator and door lock, or just the regulator. The later type has a fixed inner panel and the components are removed individually. **Q**

PART A : EARLY FRONT DOORS

• **Step A1:**
Lower the window fully and remove the door trim panel. See Job 11, Type A.

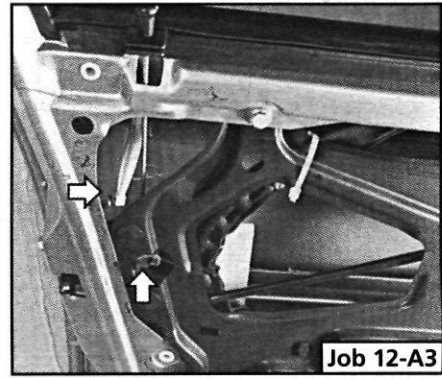

• **Step A2:**
Peel off the transparent covering from the door panel and keep it in a dust free place so that it will re-stick easily when refitted.

• **Step A3:**
Disconnect the lock control rod and the door opening rod (both arrowed).

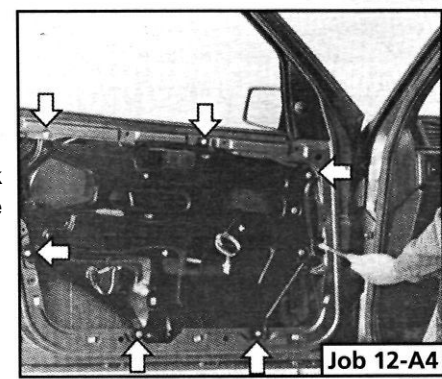

• **Step A4:**
Undo and remove the six bolts and nuts (arrowed) fixing the subframe to the door.

• **Step A5:** Undo the three lock securing bolts (arrowed), then unplug the wires from the lock and window motor (when fitted), withdraw the subframe downwards complete with the window glass and lock.

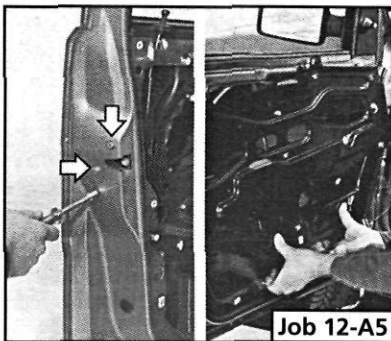

Job 12-A5

LJ **Step A6:** Remove the securing clip (1)....

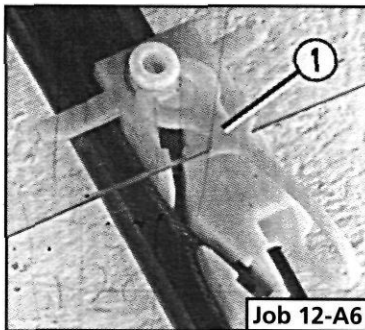

Job 12-A6

• **Step A7:** ... and release the electric window pin.

LJ **Step A8:** Remove the window glass.

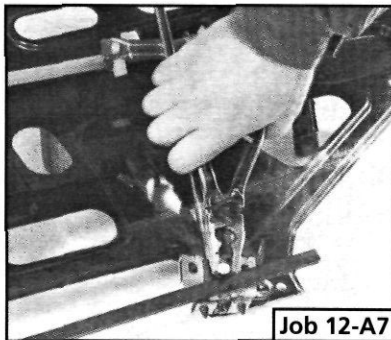

Job 12-A7

U **Step A9:** Undo the fixings on the subframe....

U **Step A10:** ... and remove the electric motor (when fitted) and window lifting gear.

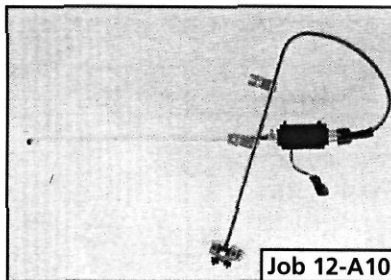

Job 12-A10

• **Step A11:** The external handle is removed by undoing the two nuts farrowed and spannered).

• **Step A12:** Re-assemble the frame in reverse order and install as unit.

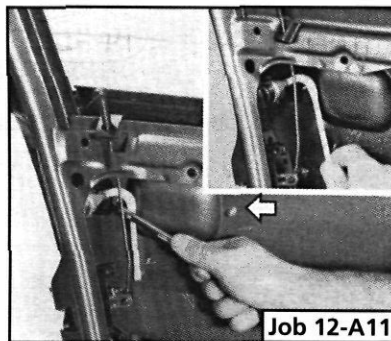

Job 12-A11

U **Step A13:** Mount the subframe with just two bolts, screwed in but not tightened and carry out the following test.

• **Step A14:** TEST FOR ELECTRIC WINDOWS: For this an ammeter is required and should be connected in series with the window control circuit. The peak consumption should not exceed 12A (with a mean value of 8A).The window lifting time should not exceed 6 seconds. If the current is too high or the time too long, check the window to guide alignment and adjust the frame until all is within the set limits.

• **Step A15:** TEST FOR MANUAL WINDOWS: Align the glass in the runners so that it moves with a small amount of resistance over the whole of its travel. The glass should then stay in any set position. Keep making minor adjustments until correct.

LJ **Step A16:** When you are satisfied that the subframe is correctly positioned, fit the remaining nuts and bolts and tighten them all.

LJ **Step A17:** Continue to refit in the reverse order of removal.

PART B : EARLY REAR DOORS

LA **Step B1:** Lower the window fully and remove the door trim panel. See Job 11, Part A.

LJ **Step B2:** Peel off the transparent covering from the door panel and keep it in a dust free place so that it will re-stick easily when refitted.

LJ **Step B3:** Remove the external handle by disconnecting the lock safety rod and undoing the fixing bolts (arrowed).

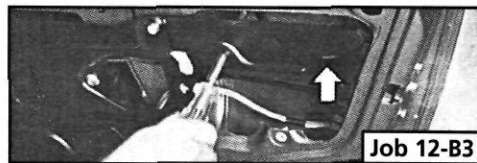

Job 12-B3

LJ **Step B4:** Remove the three lock bolts (arrowed).

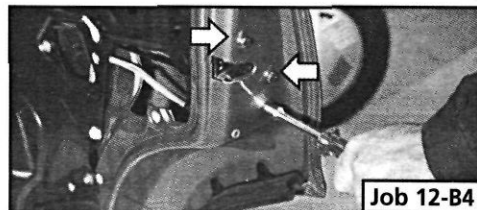

Job 12-B4

LJ **Step B5:** Unplug all electrical connectors inside the door and undo all the six mounting bolts and nuts (arrowed) securing the subframe.

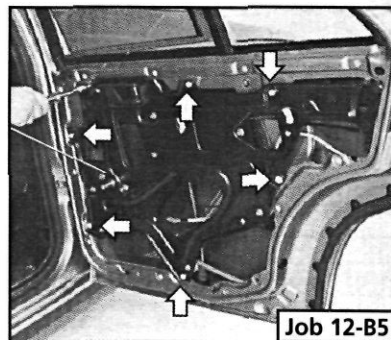

Job 12-B5

LJ **Step B6:** Remove the complete assembly from the door shell.

LJ **Step B7:** Remove the securing clip....

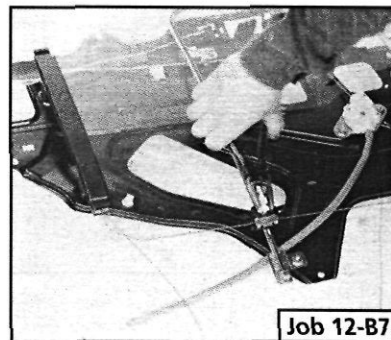

Job 12-B7

• **Step BS:** ... and release the window glass

LJ **Step B9:** Remove the window glass.

LJ **Step B10:** Undo the fixings and remove the window motor and lifting gear.

LJ Step B11: Remove the lock from the subframe by levering out the two plastic retaining studs with a flat bladed tool (preferably two-pronged).

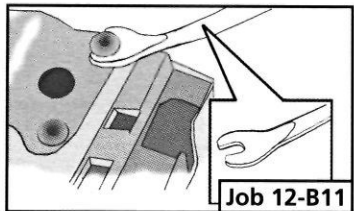

Job 12-B11

U Step B12: The window channels can also be unbolted if required.

G Step B13: Re-assemble and refit by following Steps A13 to A18.

PART C: LATER FRONT AND REAR DOORS

IMPORTANT NOTE: We cover removal/replacement of the electrically operated window mechanism. Removal of the manually operated regulator mechanism is similar in principle to the earlier type. See **PART A: EARLY FRONTDOORS**

LJ Step C1: Remove the door trim panel. See **Job 11**

G Step C2: Remove the transparent covering from the door panel and keep it in a dust free place so that it will re-stick easily when refitted.

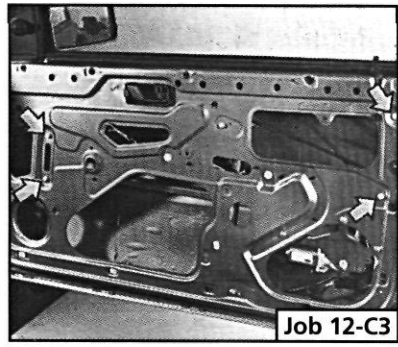

Job 12-C3

- Step C3:** Undo the four bolts (arrowed) and lower the glass to allow the release of the electric window pin...

LJ Step C4:...by releasing the clip (see illustration **Job 12-A6**). Withdraw the glass.

making it easy!

Step C5: When refitting the glass, move it downwards, then up and backwards....

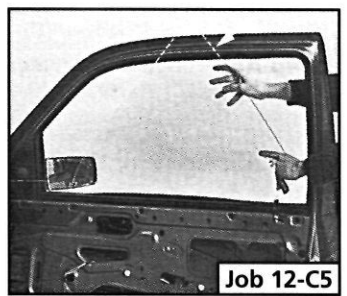

Job 12-C5

- Step C6:**... so that the guide (arrowed) engages with the door window frame.

- Step C7:** To remove the window regulator/motor, first unplug the electrical connection from position a....

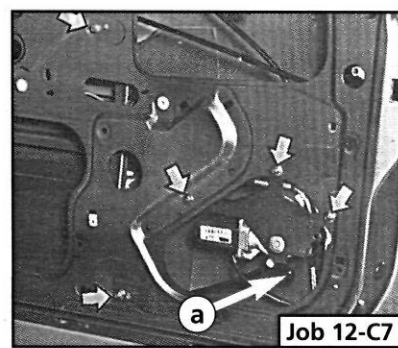

Job 12-C7

- Step C8:** then undo the five screws (see illustration **Job 12-C7** arrowed)....

LJ Step C9:.... and withdraw the regulator, motor and guide assembly from the door.

LJ Step C10: Refit in the reverse order of removal and adjust the fit of the glass in the channels for smooth operation without binding. The glass should then stay in any set position.

LJ Step C11: Remove the door trim panel and the transparent covering. See **Job 11** and **Step B1**.

- Step C12:** Undo the three bolts (arrowed)....

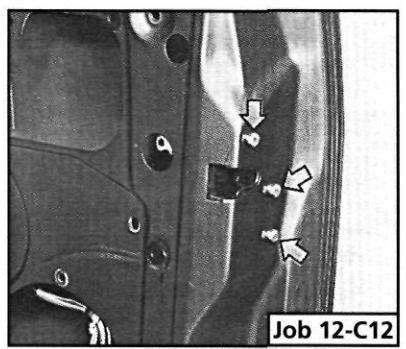

Job 12-C12

LJ Step C13:... Manoeuvre the lock until you are able to disconnect the central locking wires and release them from their securing points on the door panel

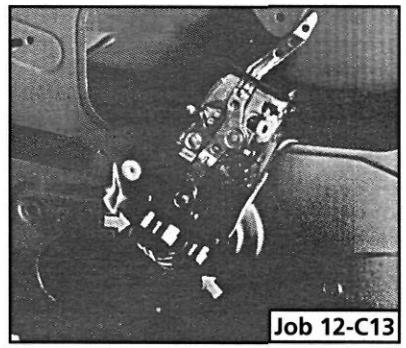

Job 12-C13

LJ Step C14: Remove the lock complete with the remote interior handle rod and locking rod.

- Step C15:** The exterior door handle fixing nuts can be reached inside the door panel just above the lock - be careful not to drop them inside the panel.

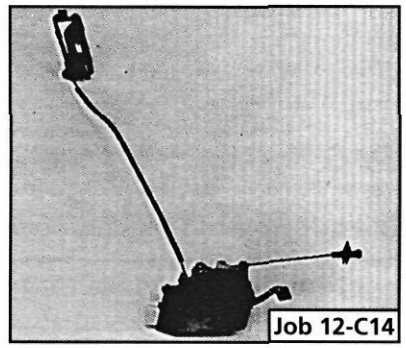

Job 12-C14

- Step C16:** Refit in the reverse order of removal.

Job 13. Door removal, replacement and adjustment.

H INSIDE INFORMATION! To avoid the need to 're-hang' the door, it is best to remove the hinge pins rather than unbolt the hinge from the body, unless necessary. **Q**

PART A: DOOR REMOVAL.

LJ Step A1: Remove the door lining by following the steps outlined in the relevant part of **Job 11**.

LJ Step A2: Disconnect all the electrical cables from the electrical components inside the door.

SAFETY FIRST!

If an air bag has been fitted to your vehicle:

- **DO NOT** apply stickers or any other objects to the steering wheel as this may restrict the operation of the air bag.
- **NEVER** travel with anything on your lap or in front of your chest
- **NEVER** drive with a cigarette, pipe, pen or any other object in your mouth.

J12. INTERIOR LIGHTS

COURTESY LIGHT

On most models the courtesy light is positioned in the centre of the roof.

- With the light switch in the central position the light turns on when either of the front doors is opened.
- When the switch is in the right position the light remains on.
- With the switch in the left position the light is switched off.

J13. SUNROOF OPERATION

13A. SUNROOF CONTROLS

As an optional extra some models are fitted with a sunroof. To operate the manually operated sunroof:

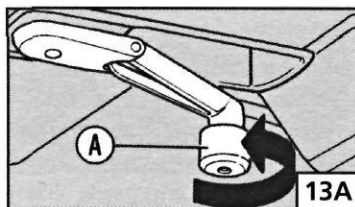

- Pull handle A down and turn anti-clockwise. The sunroof lifts up and then slides back.

13B. To operate a sunroof with electric controls:

- Press rocker switch C either at the front or back edge to open or close the sunroof.

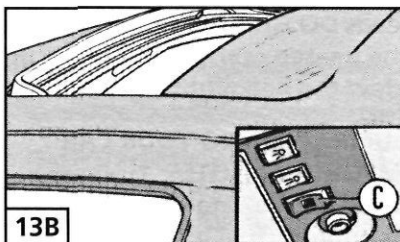

BONNET AND LUGGAGE COMPARTMENT

J14. BONNET

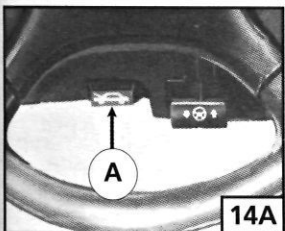

OPENING THE BONNET

- 14A. Pull the bonnet release lever A, toward the steering wheel to release the bonnet catch.

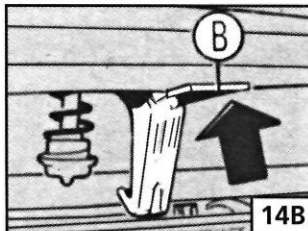

- 14B. Positioned at the front of the bonnet is a release catch B. Lift catch up to release.

- 14C. Lift the bonnet and pull the support rod C out of its holder.

When the bonnet is fully raised, place the tip of the rod in the recess B located in the bonnet.

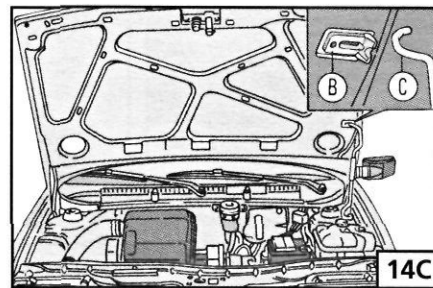

• 15. LUGGAGE COMPARTMENT

INCREASING THE CARGO AREA

FOLDING THE BACK SEATS - Use the following procedure to fold the rear seat forwards:

- Pull the strap at the centre of the backseat cushion in an upwards direction to swing up the seat cushion.

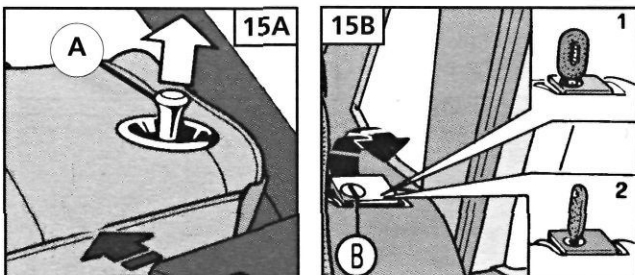

- 15A. On models fitted with lever A, pull the lever up to release the seat backrest.

- 15B. Models fitted with a lockable lever B, turn the key to position 2 to unlock (1 to lock), then lift the lever in the direction arrowed.

- Fold the backrest cushion forwards.

To repositioning the back seats - reverse the order described above.

WHEEL CHANGING

J16. CHANGING THE WHEEL IN AN EMERGENCY

CHANGING A WHEEL

Whenever possible park the car on firm level ground. Put the car into reverse gear and pull on the handbrake. Keep chocks or pieces of wood in the boot of your car, which can be wedged in front and behind the diagonally-opposite wheel to the one being removed to prevent the car from rolling. If you haven't got a piece of wood handy, use large rocks or stones.

The location of the spare wheel, jack and tools for most models is in the luggage compartment under the mat. However on some models the spare wheel and tools are located in a storage container within the side walls of the rear luggage compartment.

Q **INSIDE INFORMATION!** As an alternative to steps A1 and A2 you can disconnect all the electrical plugs under the dashboard, which have wires which go through to the door. **H**

LJ Step A3: Support the door using a trolley jack with a wad of rag on its pad for protection.

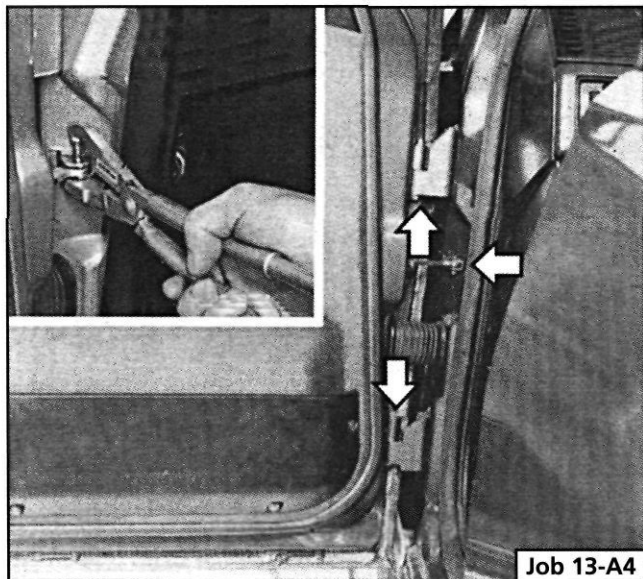

d Step A4: Remove the door restricter pin (inset and arrowed) with FIAT tool 1878081000 or similar. With a helper holding the door steady, undo the hinge pin bolts farrowed), and lift the door clear.

LA Step A5: Refit in reverse order and retighten the hinge pin bolts.

PART B: DOOR STRIKER ADJUSTMENT.

making it easy! When checking the door adjustment, keep a window open to prevent air pressure from resisting door closure.

LA Step B1: Close the door gently at first to check the lock-to-striker engagement.

Q Step B2: Slacken the screws fixing the striker to the door post just enough to allow you to tap the striker to a new position.

LA Step B3: Adjust the striker in or out and up or down by small degrees until correct.

d Step B4: Fully tighten the striker screws and recheck the adjustment.

H **INSIDE INFORMATION!** Shims with a thickness of 1mm are available from your FIAT dealer to fit under the door lock striker, if necessary. **D**

PART C: DOOR HINGE ADJUSTMENT.

IMPORTANT NOTE: Have an assistant support the weight of the door as the hinge bolts are slackened.

d Step C1: Support the car on axle stands and remove the road wheel on the side to be worked on.

• Step C2: If adjusting a front door, remove the front wheel arch liner by undoing the retaining studs and screws. Rear doors are adjusted with the front door open.



• Step C3: Slacken the hinge screws by just

enough to allow the door to be moved. Adjust the door position until correct and retighten the screws to 35Nm.

D **INSIDE INFORMATION:** The bolts fixing the hinges to the bodywork are very tight. Use a torque wrench or a proprietary extension on your socket wrench when slackening them. **H**

Job 14. Door mirror - replacement.

PART A: MANUAL OPERATION

• Step A1: Pull off the rubber adjusting lever cover (a)...

U Step A2: ...and unscrew the ring nut (b).

U Step A3: Lever off the plastic panel (c)...

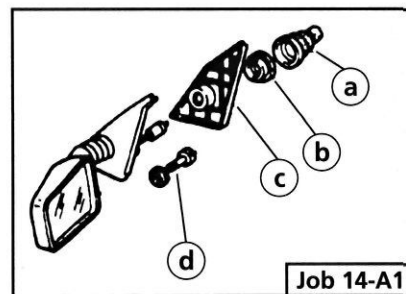

LA Step A4: ...undo the two mounting screws (d) and remove the mirror.

U Step A5: Refit in reverse order.

PART B: ELECTRIC MIRROR

d Step B1: Refer to Job 11 to remove the door trim panel.

Q Step B2: Pull back the plastic protective sheet at the forward edge to expose the mirror wires.

Q Step B3: Locate the plugs - behind the kick panel by the inner wheel arch, and disconnect them, pulling them through to the door.

Q Step B4: Lever off the plastic trim, (see Step A3) unplug the electrical connections and undo the securing screws (see Step A-4) and withdraw the mirror and wiring.

d Step B5: Refit in the reverse order of removal.

Job 15. Sun roof - removal and refitting.

PART A: GENERAL

H INSIDE INFORMATION! If an electric sunroof fails to work, it can be operated manually with the aid of a key positioned behind the cover panel in the roof light assembly. By engaging the key in the exposed drive pin, you can turn it and adjust the roof position. **Q**

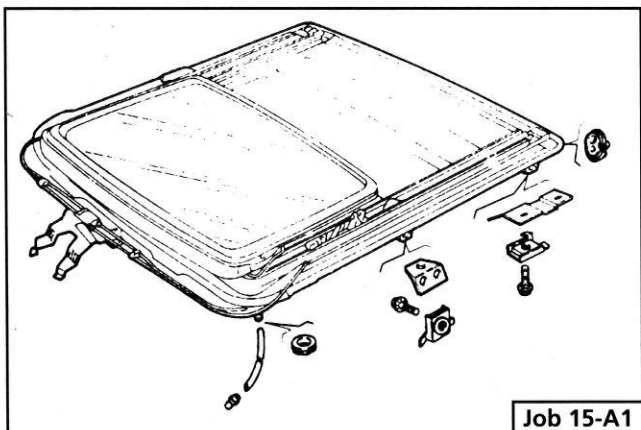

Job 15-A1

• **Step A1:** SPECIAL NOTE. Here we cover the replacement of the electric motor (where fitted) and the glass roof panel. We strongly recommend that any further work, which could involve the removal of the headlining, should be entrusted to your FIAT agent or body specialist.

PART B: TO REMOVE THE MOTOR:

LJ Step B1: Close the sunroof fully and then disconnect the battery earth lead.

LJ Step B2: Carefully lever out the panel cover and remove the roof light lens.

Q Step B3: Undo the screws and lower the panel...

Q Step B4: --then unplug the two connectors from the other side of the panel.

Q Step B5: Unplug the connector from the motor cable, once exposed...

• **Step B6:** ...then undo the mounting screws (arrowed).

Q INSIDE INFORMATION: The relay is found here (a), **Q**

• **Step B7:** You can now withdraw the motor.

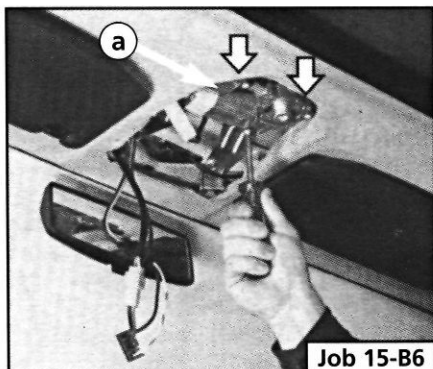

Job 15-B6

LJ Step B8: Refit by reassembling in reverse order.

PART C: TO REMOVE THE GLASS PANEL:

LJ Step C1: Position the glass in the fully tilted mode and remove the mouldings (arrowed) by sliding them rearwards.

• **Step C2:** Undo the mounting bolts (two per side) found behind the mouldings...

• **Step C3:** ...and raise the glass to remove it from the frame.

LJ Step C4: Refit in the reverse order.

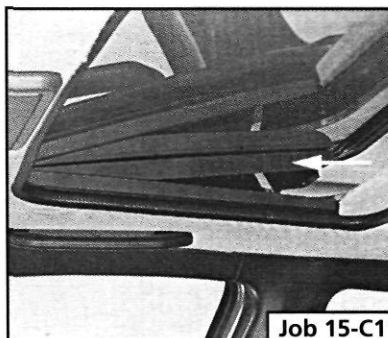

Job 15-C1

Job 16. Front seats - removal and refitting.

PART A: SEATS WITHOUT PRETENSIONERS

• **Step A1:** Undo the screws (arrowed) and remove the seat mounting cover from both sides.

U Step A2: Undo the four bolts - two per side of each seat - fixing the runners to the floor and remove the seat.

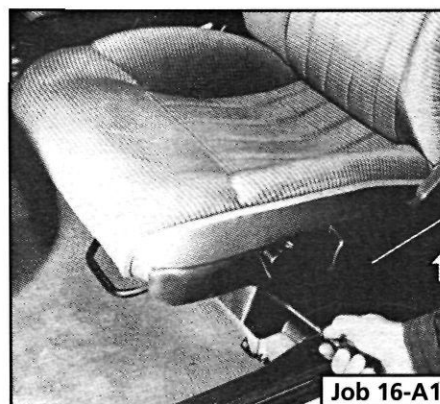

Job 16-A1

PART B: SEATS WITH SEAT BELT PRETENSIONERS - REMOVAL

IMPORTANT NOTES: i) In a collision, the pretensioners are activated whether the belt is buckled or not. They cannot be reset and must be replaced! If the seat belt was buckled, it too, must be replaced.

ii) Read **Safety First! Steps B2** and **B3**.

SAFETY FIRST!

- Handle pretensioners with extreme care - don't drop,
- Never cause impact to the tensioning device • which could set off the pre-loaded spring.
- The components must be fitted with care to avoid knocking or jarring.
- Detach the pretensioner if working on the seat
- Always insert the blue safety clip before removing or refitting the seat,
- Never attempt to service or dismantle the unit
- Never grasp the buckle or the power unit

- **Step B1: Q INSIDE INFORMATION:** The seat belt buckle has a pop-out tab to show when the pretensioner has been activated - and must be replaced. **Job 16-B2, part a** shows the normal, non-activated position. **Q**

SAFETY FIRST!

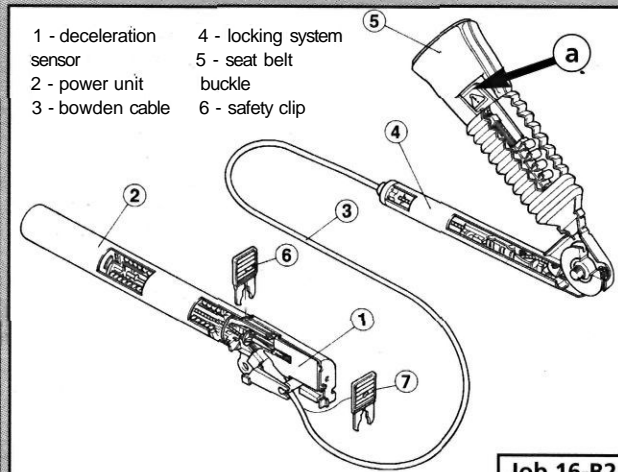

Job 16-B2

- **Q Step B2:** Before starting to remove the seat, remove the safety clip from its storage position (7) and fit it into the mechanisms shown here (6). **DO NOT** remove the seat without the safety clip in place.

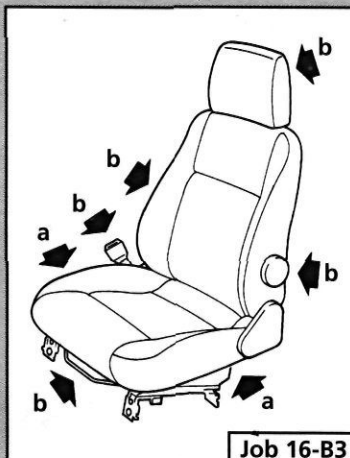

Job 16-B3

- **Q Step B3:** When removing or refitting the seat, grasp the seat at the arrow points (a) only, never where indicated by the arrow points (b).

Also, never grasp the seat by:

- the seat belt buckle assembly
- the pretensioner power unit

- **Step B4:** Remove the backrest release trim in the direction indicated by the lower arrow.



Job 16-B4

- **Step B5:** Remove the seat as described in **PART A, Steps A1** and **A2**.

Q Step B6: Turn the seat over and slide it as far forwards as it will go on its runners to provide maximum slack on the bowden cable.

Q Step B7: Using a Torx key, available from a motor accessory store, undo the bolt (see illustration **Job 17-C2, part 6**) and release the pretensioner assembly (**17-C2, part 4**)

from the buckle side of the seat (5). Unclip the cable (7) from the bracket and feed it between the base of the seat and the adjusting bar.

LJ Step B8: Undo the power unit retaining screw (see illustration **Job 17-C2, part 3**) and remove the unit (**17-C2, part 2**). Recover the rubber support block (**17-C2, part 1**) and save for re-use. **DO NOT** attempt to disassemble the unit.

PART C: 5 DOOR VERSION, REFITTING

IMPORTANT NOTE: Read **SAFETY FIRST! Steps B2** and **B3**.

Q Step C1: Check that the safety clip is properly installed - do not attempt to force it. **DO NOT** attempt to disassemble the unit.

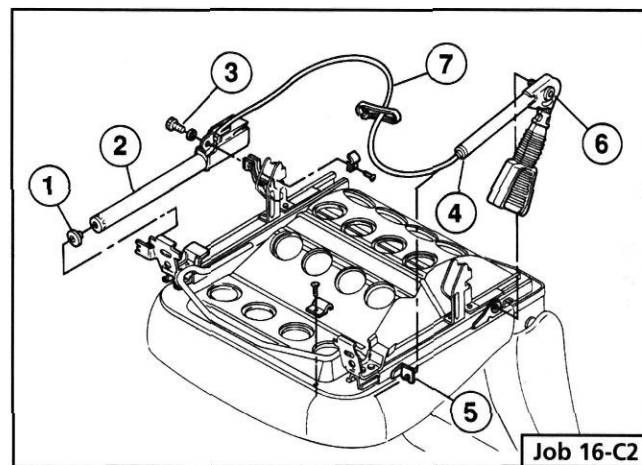

Job 16-C2

Step C2:

- Position the support block (1) between the power unit (2) and the seat bracket.
- Align the power unit (2) along the seat frame and secure it with the screw (3) and washer, tightening to 6 to 8 Nm.
- Slide the lock (4) and buckle unit between the seat base and adjusting bar and locate the lock in bracket (5). Fix the rear end with the screw (6) and tighten to between 35 and 43 Nm.

- **Step C3A:** Align the cable's white paint spots with the securing clips on the seat base. The 5 door's seat cables should look like this for the basic seat...

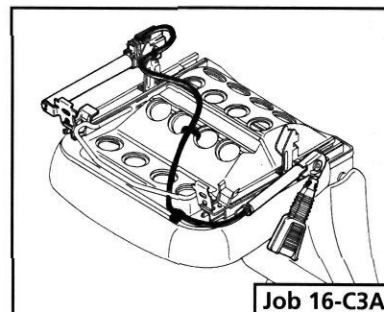

Job 16-C3A

- **Step C3B:** ...and the cables should be located like this for the height adjustable version.

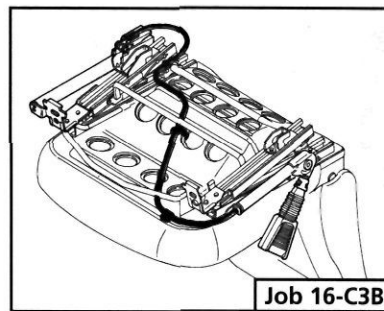

Job 16-C3B

- **Step C4:** Position the seat centrally on the runners and refit to the car, taking care to handle it as described in **Step B3**.

LI Step C5: Ensure that the seat operates smoothly and withdraw the safety clip from its slot and position it on the sensor frame cover. The unit is now operational.

PART D: 3 DOOR VERSION, REFITTING

IMPORTANT NOTE: Read **SAFETY FIRST! Steps B2 and B3.**

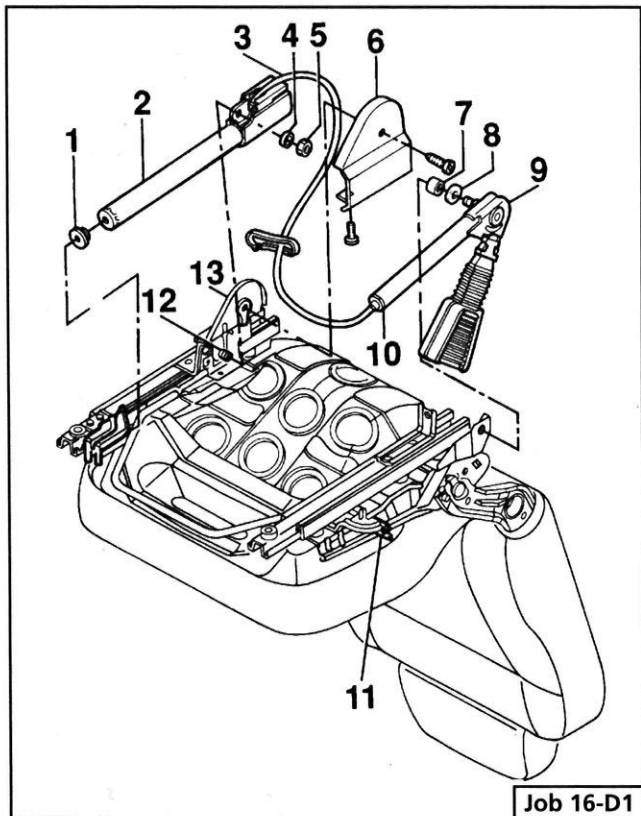

- **Step D1:**
- Position the support block (1) between the power unit (2) and the seat bracket.
- Align the power unit (2) and secure it with screw (12), washer and nut (4 and 5). Tighten to 6 to 8 Nm.
- Slide the lock (10) and buckle (9) between the seat base and the adjusting bar.
- Locate the front of the lock unit (10) into the bracket (11) and secure the other end with screw (9), positioning spacer (7) and washer (8) between the lock and seat frame. Tighten to 35-43Nm.
- Screw the cover (6) into place when the cable is correctly positioned.

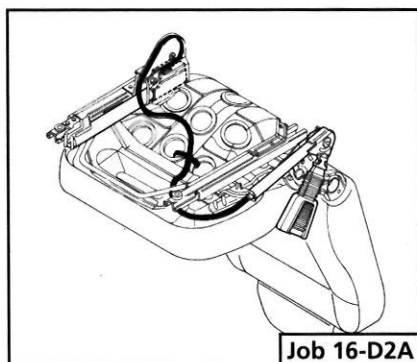

LI Step D2A: The cable run should look like this for the basic seat...

- **Step D2B:** ...and like this for height adjustable version.

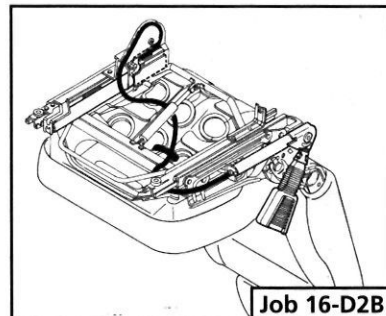

- **Step D3:** Now follow Steps C4 and C5 to complete the job.

Job 17. Rear seat - removal and refitting.

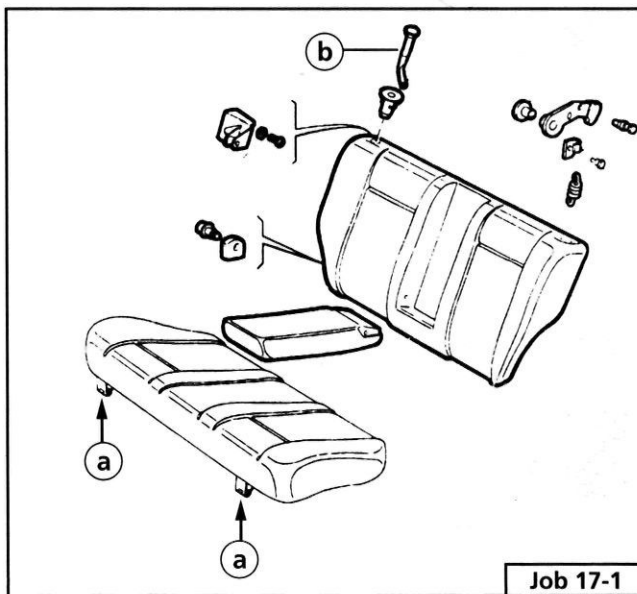

LA Step 1: Undo the fixing bolts (a) and slide out the seat cushion.

d Step 2: Lower the back rest and prise out the buttons fixing the rear compartment shelf to the backrest.

Q Step 3: Disengage the catch (see illustration Step 1, part b), undo the hinge bolts and withdraw the backrest.

LJ Step 4: Refit in reverse order.

IMPORTANT NOTE: Split rear seats also have central hinge brackets to be unscrewed.

Job 18. Headrest removal.

LJ Step 1: Raise the headrest as far as it will go.

LJ Step 2: Turn each of the support bars through 90 degrees. This releases the bar from their spring clips inside the seat backrest.

G Step 3: Lift out the headrest.

Q Step 4: After refitting, turn each support bar through 90 degrees and check that the spring clips have located in the grooves at the lower end of each support bar.



'READING' YOUR SPARK PLUGS

Champion explain how the condition of spark plug firing ends can act as a guide to the state of tune and general condition of the engine. The examples shown are assumed to be the correct grade for the engine.

NORMAL



Core nose lightly coated with grey-brown deposits. Electrodes not burning unduly - gap increasing by about 0.01 mm every 1,000 miles approximately (with the use of unleaded fuel). Spark plugs correct for engine.

HEAVY DEPOSITS



Possible causes: Fuel or oil additives. Excessive upper cylinder lubricant. Worn valve guides. Unvarying speed (stationary engine). Replace spark plugs.

CARBON FOULING



Look for dull black sooty deposits. (Unleaded fuel carbon fouling can appear similar to oil fouling). Deposits can short circuit the firing end, weakening or eliminating the spark. Check for: Over-rich mixture, faulty choke or clogged air filter. Replace spark plugs.

OIL FOULING



Deposits can short-circuit firing end, weakening or eliminating spark. Causes: worn valve guides, bores or piston rings, or while new engine is running-in. Replace spark plugs. Cure oiling problem.

OVERHEATING



Likely causes are: Over-advanced ignition timing, or faulty distributor advance mechanism. Use of low octane fuel. Weak mixture. Discard spark plugs showing signs of overheating, and cure the cause.

INITIAL PRE-IGNITION



Caused by serious overheating. Causes are those listed for overheating, but may be more severe. Corrective measures are urgently needed before engine damage occurs. Discard plugs in this condition.

SPLIT CORE NOSE



(May first appear as hair-line-crack). Probably caused by: Over-advanced ignition timing. Faulty distributor advance mechanism. Use of low octane fuel. Weak mixture. Manifold air-leaks. Cooling system problems. Incorrect gap-setting technique.

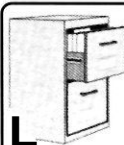

FACT FILE: CORRECT INSTALLATION

- Make sure seating areas are perfectly clean.
- Insert plug finger tight to seat. Ensure plug 'spins' freely.
- PLUGS WITH SEATING GASKET: Tighten to relevant torque setting.
- PLUGS WITH TAPER SEATS: Tighten a further 1/16th turn ONLY - no further!
- Overtightening can damage cylinder head or make taper seat plugs impossible to remove.



RECOMMENDED FL LUBRICANTS FOR YOUR FIAT TIPO AND TEMPRA

| COMPONENT/ CAPACITY | TIPO & TEMPRA 1.4 and 1.6 | TIPO SELECTA & TEMPRA SELECTA 1.6 and 1.6 i.e. | TIPO & TEMPRA DIESEL 1.7 D, 1.9 D and 1.9 TD |
|---|------------------------------|---|---|
| ENGINE CAPACITY | SELENIA 20K 3.8 L | SELENIA 20K 3.8 1/4.2L | SELENIA TURBO DIESEL 5.0 L |
| MANUAL TRANSMISSION CAPACITY | TUTELA ZC80/S 2.0 L | - | TUTELA ZC80/S 2.0 L |
| AUTOMATIC TRANSMISSION CAPACITY | - | TUTELA CVT 3.5 L (a) | - |
| DIFFERENTIALS) CAPACITY | FROM GEARBOX - | FROM GEARBOX - | FROM GEARBOX - |
| STEERING BOX CAPACITY | TUTELA K854 80 g (b) | TUTELA K854 80 g (b) | TUTELA K854 80 g (b) |
| CONSTANT VELOCITY JOINTS CAPACITY | TUTELA MRM2 95 g (each) | TUTELA MRM2 95 g (each) | TUTELA MRM2 95 g (each) |
| BRAKE FLUID RESERVOIR CAPACITY (NON-ABS) | TUTELA PLUS 3 0.40 L (c) | TUTELA PLUS 3 0.40 L (c) | TUTELA PLUS 3 0.40 L (c) |
| COOLANT CAPACITY | PARAFU 11 6.5 L (d) | PARAFU 11 6.5 L (d) | PARAFU 11 8.8 L (d) |
| WINDSCREEN WASHER TANK CAPACITY | AREXONS DPI 5.0 L | AREXONS DP1 5.0 L | AREXONS DP1 5.0 L |

NOTES:

- (a) DRAIN/REFILL CAPACITY
- (b) IF MODEL FITTED WITH POWER ASSISTED STEERING USE 0.75 L TUTELA GI/A
- (c) IF ABS BRAKING IS FITTED USE 0.52 L TUTELA TOP 4
- (d) COOLING SYSTEM AT A CONCENTRATION OF 50% COOLANT TO 50% WATER

CHANGE PERIODS: See **Chapter 5, Service Intervals**

CHAPTER 7

WIRING DIAGRAMS

IMPORTANT NOTE: Not all of the components listed here are fitted to all models.

IMPORTANT NOTES:

1. There are several hundred FIAT wiring diagrams for the whole TIPO range. This is a representative selection, covering the majority of applications. However, in the event that your car's details are not covered here, consult your nearest FIAT dealer.

2 All of the following are Tipo wiring diagrams. Tempra saloons and estates are essentially similar.

3. We have sometimes shown the wiring diagram for a 'highest' spec, model, in the knowledge that 'lower' spec, models are usually similar with the deletion of certain components.

4. 'EEC Stage 2 Engines' In late 1994, Tipo 1.4 and 2 - Litre and Tempra 1.6 MPI vehicles were modified to suit new emission regulations. These changes were NOT only engine-related. Vehicles covered by this manual are Tipo 1.4 (with engine code no. 836A4.000) and Tempra 1.6 (with engine code 159B9.000). See **Page 27** for location of codes.

KEY:

| | | | | | |
|---------------------------------|--|-----|--|-----|---|
| i | Left front light duster | 40 | PTC resistor activation relay | G | Horn button |
| 2 | Reversing light switch | 41 | 20A fuse for inlet duct heater circuit | H | Windscreen wiper stalk |
| 3a | Left horn | 42 | 25A fuse for electric window ECU | 1 | Back window wash/wipe selector |
| 4 | Electric cooling fan | 43 | junction between facia cable and heater cable | L | Heated rear windscreen switch |
| 5 | Dual contact coolant thermal switch | 44 | Earth on left hand side of facia | M | Rear screen wash/wipe switch |
| 6 | Right longitudinal cable connection | 45 | Junction between facia cable and left front door cables | N | Windscreen wiper speed switch |
| 7 | Right front earth | 46 | Electric window control unit | 56 | Junction: facia cable and r.h. rear door cables |
| 8 | Right front light cluster | 47 | Provision for left front speaker | 57 | Glove compartment light bulb |
| 9 | Right horn | 47A | Provision for left rear speaker | 58 | Facia cable coupling with right front door cables |
| 10 | Screen/rear window washer pump | 48 | Supplementary earth point | 59 | Facia cable coupling with right front door cables |
| 11 | Left brake pad wear sensor | 50 | Instrument panel | 60 | Provision for right front speaker |
| 11A | Right brake pad wear sensor | A | Direction indicators warning light | 60A | Provision for right rear speaker |
| 12 | Ignition coil | B | Side lights warning light | 61 | L.h. button for courtesy light and electric window |
| 12A | Ignition coil with power module | C | Main beam headlights warning light | 62 | Junction between rear cable and left rear door cables |
| 12B | Ignition coil with H.T. points | D | Heated rear windscreen warning light | 63 | Junction between rear cable and left front door cables |
| 13 | Digiplex electronic ignition control unit | E | Rear fog lights warning light | 64 | Left front door lock motor and left front door open warning light |
| 13A | Digiplex electronic ignition lead connection | E1 | Fog lights warning light | 65 | Left front electric window motor |
| 13C | Diagnostic socket for Digiplex electronic ignition | F | Hazard warning lights warning light | 66 | Electric front window control buttons |
| 14 | Left front earth | G | Battery recharging warning light | 67 | Cigar lighter |
| 15 | Battery earth | H | Insufficient engine oil pressure warning light | 68 | Braking light switch |
| 16 | Engine coolant temperature sender unit | I | Trip counter | 69 | Passenger compartment courtesy light |
| 17 | Battery | J | Left brake lining wear warning light | 69A | Passenger compartment courtesy light with door lock remote control receiver |
| 18 | Ignition distributor | J1 | Seat belt undone warning light | 70 | Hand brake warning light switch |
| 19 | Spark plug | K | Handbrake on and low brake fluid level warning light | 71 | Passenger compartment ventilation fan switch |
| 20 | Spark plug | L | Choke warning light | 71A | Passenger compartment ventilation control |
| 21 | Spark plug | M | ABS failure warning light | 72 | Passenger compartment ventilation fan speed regulation resistor |
| 22 | Spark plug | N | Instrument panel light bulbs | 73 | Passenger compartment ventilation fan |
| 23 | TDC sensor | O | Fuel level gauge | 74 | Heater controls light bulbs |
| 24 | Alternator | P | Coolant temperature gauge | 75 | Right front door lock motor and right front door open warning light |
| 25 | Oil pressure switch | P1 | Engine oil pressure gauge | 76 | Right front electric window motor |
| 26 | Connector block | P2 | Engine oil temperature gauge | 77 | Right front electric window control button |
| 27 | Brake fluid level sensor | Q | Clock | 78 | R.h. button for courtesy lights and window |
| 28 | Left side turn signal | R | Heater plugs warning light | 79 | Luggage compartment lighting |
| 30 | Idle cut-out device | S | Speedometer | 80 | Left rear earth |
| 31 | Starter motor | SI | Speed warning light | 80A | Right rear earth |
| 32 | Throttle valve sensor | T | Rev counter | 81 | Rear cable connection |
| 33 | Pulse generator for speedometer signal | U | Trailer turn signal warning light | 82 | Left tail-light cluster |
| 34 | Windscreen wiper | X | Water in fuel filter warning light | 83 | Left rear door lock motor |
| 35 | Right side turn signal | Y | Excessive turbocharging air pressure warning light | 84 | Fuel level gauge |
| 36 | P.T.C. resistor for heating fuel duct | Y1 | Lambda probe failure warning light | 85 | Tailgate lock/release motor |
| 37 | Thermal switch for PTC | Z | Excessive automatic transmission fluid temperature warning light | 86 | Left number plate light |
| 38 | Vacuum sensor for vacuum gauge | Z1 | Injection system failure warning light | 87 | Right number plate light |
| 39 | Fuse and relay control unit | 51 | Ignition switch | 88 | Rear window wiper motor |
| E2 | Turn signal and hazard warning light flasher | 53A | Available for radio | 89 | Heated rear windscreen |
| E4 | Fog light relay | 53B | Available for radio | 90 | Right tail-light cluster |
| E5 | Horn relay | 54 | Hazard warning lights switch | 91 | Right rear door lock motor |
| E6 | Heated back window relay | 55 | Stalk unit | 92 | Glow plug preheating system ECU |
| E7 | Switch discharge connector | A | Rear fog lights switch | 93 | Glow plugs |
| E9 | Windscreen wiper intermittent function | B | Exterior lighting selector | 94 | Engine cooling fan first speed additional resistor |
| E10 | Rear fog light relay | C | Control lighting bulb | 95 | 30A fuse for engine cooling fan |
| E11 | Dipped beam relay | D | Light flasher button | 96 | Switch for automatic advance |
| E12 | Main beam relay | E | Turn signal stalk | | |
| E13 | Side light control relay | F | Dipped/main beam headlight selector | | |
| E14 | Central locking electronic control unit | | | | |
| E1-E3-E8-E15-available (unused) | | | | | |

| | | |
|---|---|---|
| 97 Solenoid for automatic cold-start advance device (K.S.B.) | 160 Potentiometer | 270 Front cable connection |
| 98 Engine cut out solenoid on injection pump | 161 Junction between engine lead and facia leads for SPI system | 271 Maximum turbo boost pressure warning light switch |
| 99 Cooling fan second speed activation relay | 161A Engine lead connection for IAW injection system | 272 Front cable connection |
| 100 Fuel pump facia lead connection | 163 Bosch SPI electronic injection control unit | 273 Front cable connection |
| 101 Electromagnetic sensor for rpm sensor | 163A Bosch SPI ignition/injection ECU | 274 Front cable connection |
| 102 Turbocharger air pressure switch | 164 Diagnostic socket (S.P.I.) | 281 Left-hand brake lining connection cable joint |
| 104 10A fuse for ABS device | 165 Electric fuel pump | 281A Right-hand brake lining connection cable joint |
| 105 Connection for anti-lock brake circuit (Antiskid) | 166 Hot Lambda probe | 282 CO regulation potentiometer |
| 106 Left hand brake lining wear sensor lead connection | 167 Step motor | 286 Electromagnetic sensor on flywheel |
| 107 Cut-off control module | 171 Air temperature sender unit | 287 Seat belt undone indicator switch |
| 108 Cable connection for air conditioner | 173 Throttle position sensor | 288 Headlight washer intermittent function |
| 109 Front cable connection | 174 Absolute pressure sender unit | 292 Earth for anti-lock brake system (A.B.S.) |
| 111 Electric window ECU supply lead connection | 180 Rem. contr. switch for legally specified system | 293 Earth for air conditioner fan |
| 112 Sensor on left front wheel | 181 Daylight side light remote control switch | 294 Facia lead connection |
| 113 Sensor on right front wheel | 182 Daylight side light remote control switch | 295 Connection between facia cable and rear cable |
| 114 Sensor on left rear wheel | 184 Power earth | 297 EGR device ECU |
| 115 Sensor on right rear wheel | 185 Electronic earth | 298 Diagnostic socket for EGR device |
| 116 Hydraulic control unit (A.B.S.) | 186 Electric sun-roof ECU | 299 EGR device control solenoid |
| 117 ABS control relay | 187 Electric sun-roof circuit connection | 300 EGR coolant temperature recording sensor |
| 118 Anti-lock brakes electronic control unit (A.B.S.) | 188 Electric sun-roof end-stop sensor microswitch | 301 Potentiometer on injection pump |
| 119 Device for heated filter | 189 Sun-roof operating motor | 302 Sensor connection cable junction |
| 120 Heated filter device relay | 190 Safety pressure switch | 303 Low engine oil level indication sensor |
| 121 20A fuse for heated filter device | 199 IAW multiple relay | 304 Low coolant level indication sensor |
| 122 Device for deteating presence of water in fuel filter | 200 Earth on hydraulic control unit bracket | 305 Low washer fluid level indication sensor |
| 123 Left fog light | 200A IAW injection/ignition ECU bracket earth | 306 Oil temperature indication sensor |
| 124 Right fog light | 207 Starter enablement relay | 307 Oil pressure indication sensor |
| 125 Connection between front cable and fog light cables | 208 Switch on gearbox indicating reverse or neutral | 308 Junction with coolant temperature sender unit leads |
| 126 Fog light switch | 209 Switch on gear selector | 311 Front cable connection |
| 127 Sun-roof activation switch | 210 Automatic transmission speed selection ECU (CTX) | 312 Front cable connection |
| 129 Electric door mirror control switch | 211 Parking not engaged warning light | 313 Junction between facia lead and legally-specified leads |
| 130 Electrically-adjustable and heated right-hand door mirror | 214 Automatic transmission lead connection | 314 Relay for legally-specified system |
| 130A Electrically-adjustable and heated left-hand door mirror | 215 T.D.C. AND RPM SENSOR (I.A.W.) | 316 60A fuse for air conditioning system |
| 131 Left headlight wiper motor | 216 Injection/ignition ECU I.A.W. | 317 40A fuse for air conditioner system |
| 132 Right headlight wiper motor | 219 1st injector | 318 Diagnostic socket for IAW injection system |
| 133 Headlight washer pump | 220 2nd injector | 319 Automatic transmission device display (Volkswagen) |
| 135 Left front seat heat pads | 221 3rd injector | A Economy warning light |
| 135A Right front seat heat pads | 222 4th injector | 8 Sporty drive warning light |
| 136 Air conditioner cable connection | 224 15A fuse for injectors | 320 Right rear earth for automatic transmission (Volkswagen) |
| 137 Air conditioner cable connection | 225 Idle speed control solenoid | 327 Junction with injector cable |
| 138 Air conditioning system compressor | 226 Provision for air conditioner | 328 Advance cut out heat switch |
| 139 Three stage pressure switch | 228 Ignition distributor with timing sensor | 329 Remote control switch for shifting advance curve |
| 141 Air Recirculation/outside air intake control motor | 231 Coupling with injection lead | 330 Negative battery lead connection |
| 142 Air conditioning system switch | 241 Automatic transmission electronic control unit (Volkswagen) | 331 Prewired engine lead connection |
| 143 Outside air/recirculation switch | 242 Automatic trans, lead connection (Volkswagen) | 332 Right hand rod lead connection |
| 146 Air conditioning system ECU | 243 Automatic trans, lead connection (Volkswagen) | 333 Right front seat heating control switch |
| A 40A fuse for engine cooling fan | 244 ECU for decoding speed selector lever position | 334 Right front seat heating activated warning light |
| B 30A fuse for interior ventilation fan and air recirculation motor | 245 Solenoid unit on transmission | 335 20A fuse for headlight washer system |
| C 5A fuse for compressor | 246 Diagnostic connection for automatic transmission (Volkswagen) | 336 Air conditioning system switch cable connection |
| D Interior ventilation fan and air recirculation motor relay | 247A Automatic transmission lead connection (Volkswagen) with I.A.W. injection system | 337 Ignition coil (1-4) |
| E Compressor dual contact relay | 248 Automatic transmission lever lock solenoid | 338 Ignition coil (2-3) |
| F Cooling radiator fan first speed relay | 249 Kick-down switch | N.D. Connector block welded with ultrasound (band in wiring harness) |
| H Relay for compressor activation | 250 Rpm electromagnetic sensor | Wiring colours: |
| I Timer for engine cooling fan | 251 Car speed electromagnetic sensor | A Light blue |
| 147 Fast idle valve | 252 Multifunction switch unit | B White |
| 148 Additional resistor for DIM-DIP circuit | 253 Sporty drive switch | C Orange |
| 149 DIM-DIP circuit relay | 261 Junction between facia cable and right rear door cables | G Yellow |
| 150 7.5A fuse for DIM-DIP circuit | 262 Facia lead connection | H Grey |
| 151 Fuel pump control relay | 263 Check-panel display | L Blue |
| 152 SPI ECU and injector supply relay | A Front side light failure warning light | M Brown |
| 152A Injector control contactor | B Driver side front door open warning light | N Black |
| 153 NA fuel vapour cut-off solenoid | C Driver side rear door open warning light | R Red |
| 154 NC fuel vapour cut-off solenoid | D Tail-gate open warning light | S Pink |
| 155 10A fuse for fuel pump | E Passenger side rear door open warning light | V Green |
| 155A 25A fuse for fuel pump and injectors | F Passenger side front door open warning light | Z Violet |
| 156 Injector and air temperature sensor | G Rear side light failure warning light | |
| 157 Resistor | H Rear fog light failure warning light | |
| 158 10A fuse for Lambda probe | I Right brake light failure warning light | |
| 158 5A fuse for I.A.W. ECU | L Number plate light failure warning light | |
| 159 Coolant temperature sender unit | M Left brake light failure warning light | |
| | 264 Recharging indicator cable connection | Most wires have two colours, shown as, for example, CN, which means Orange and Black. |
| | 269 Air conditioning cable connection | |

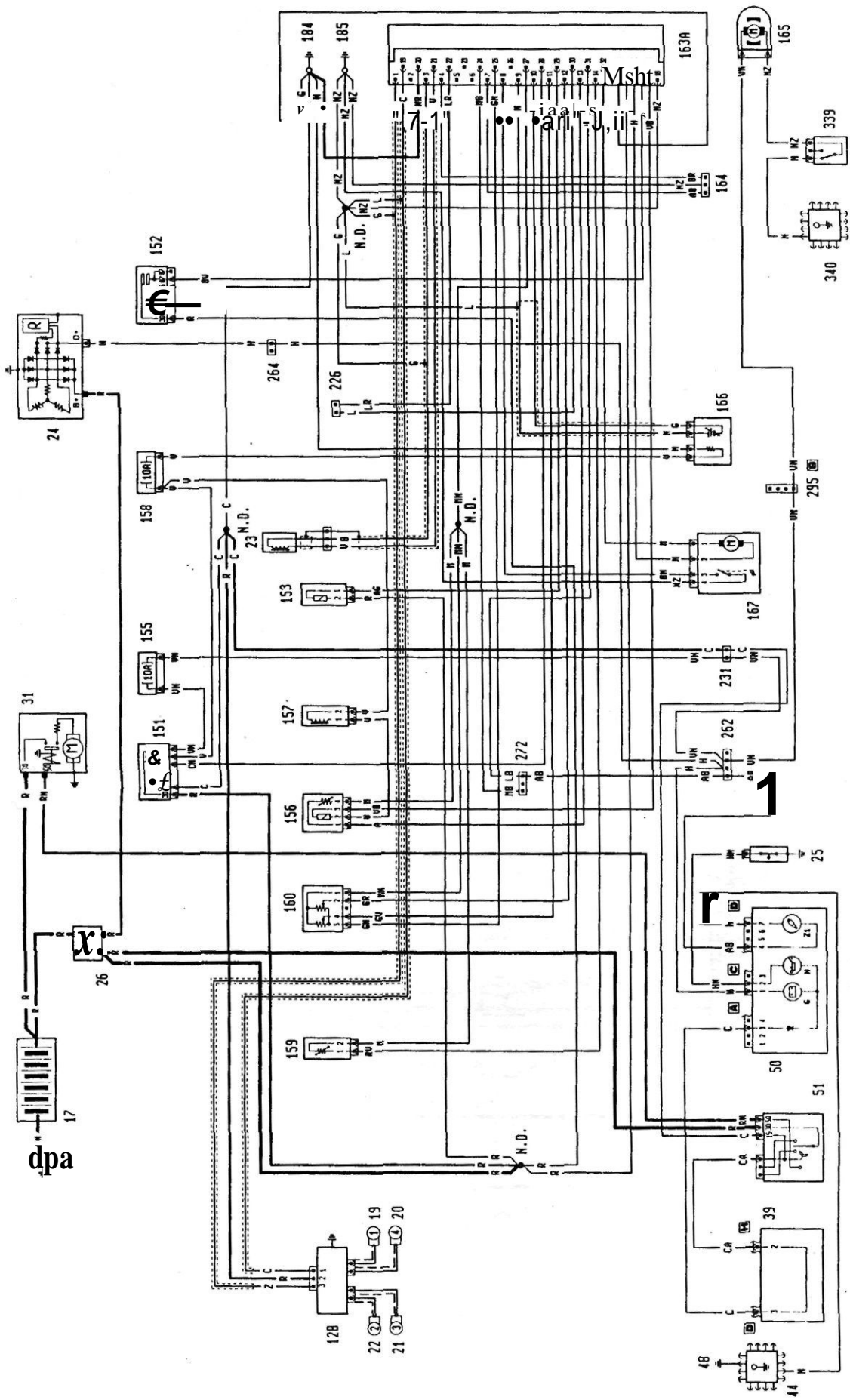

Diagram 1: Model: 1372S - Starter - Electronic Ignition and Fuel Injection (Bosch Monomotronic SP1) - Charging System and Warning Light - Oil Pressure Warning Light - Fuel Injection Fault Warning Light

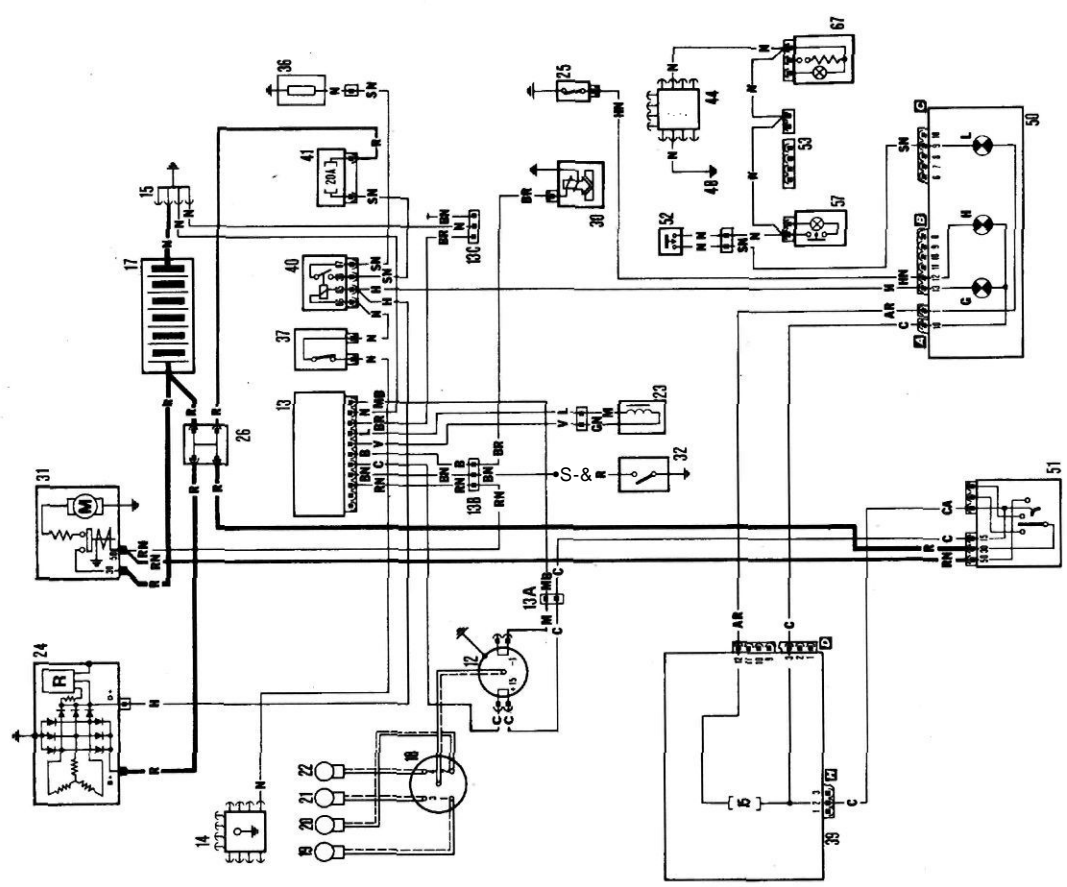

Diagram 2: Model: 1600 DGT - Starting - Digiplex Electronic Ignition - Charging - Oil Pressure Warning Light - Choke Warning Light (NB. 1400 is similar)

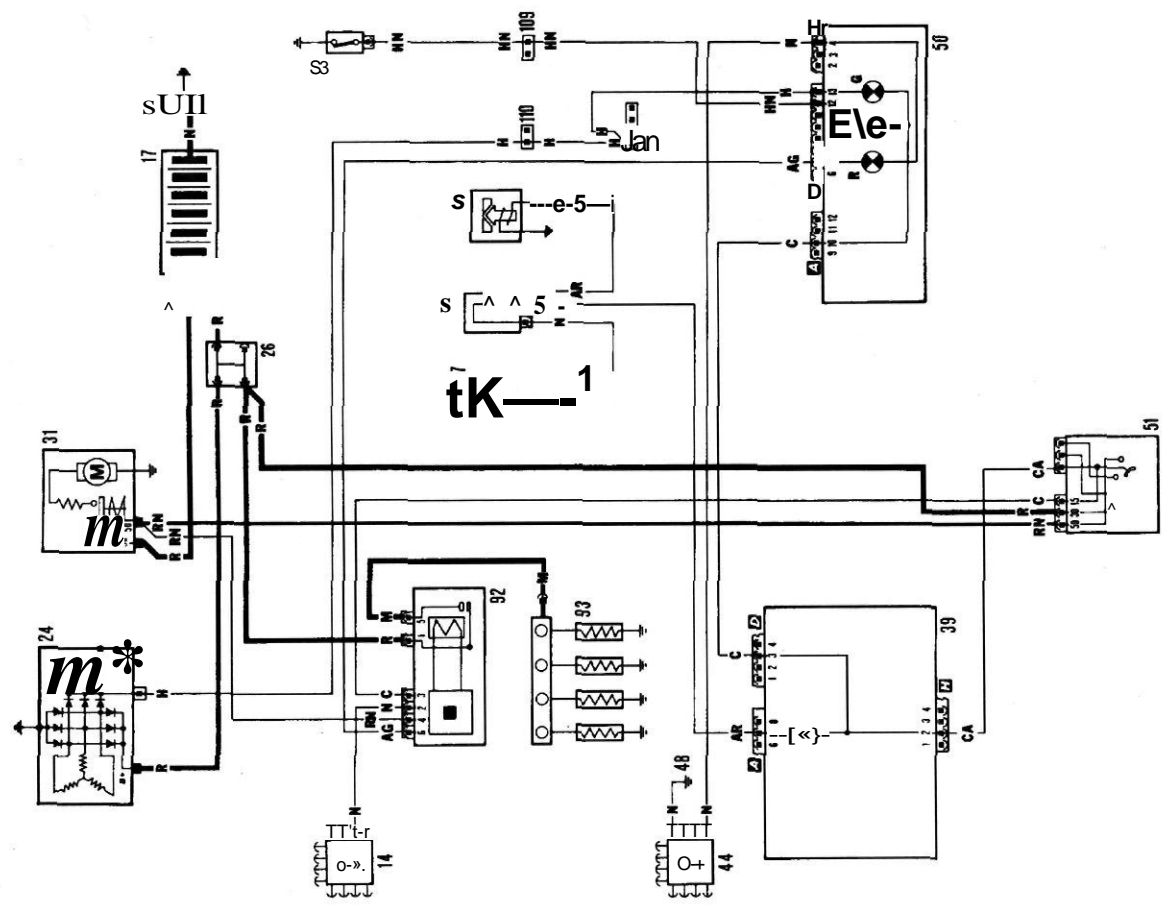

Diagram 3: Model: 1930 Turbo Diesel - Starting - Charging - Plug Preheating System and Warning Light - Oil Pressure Warning Light

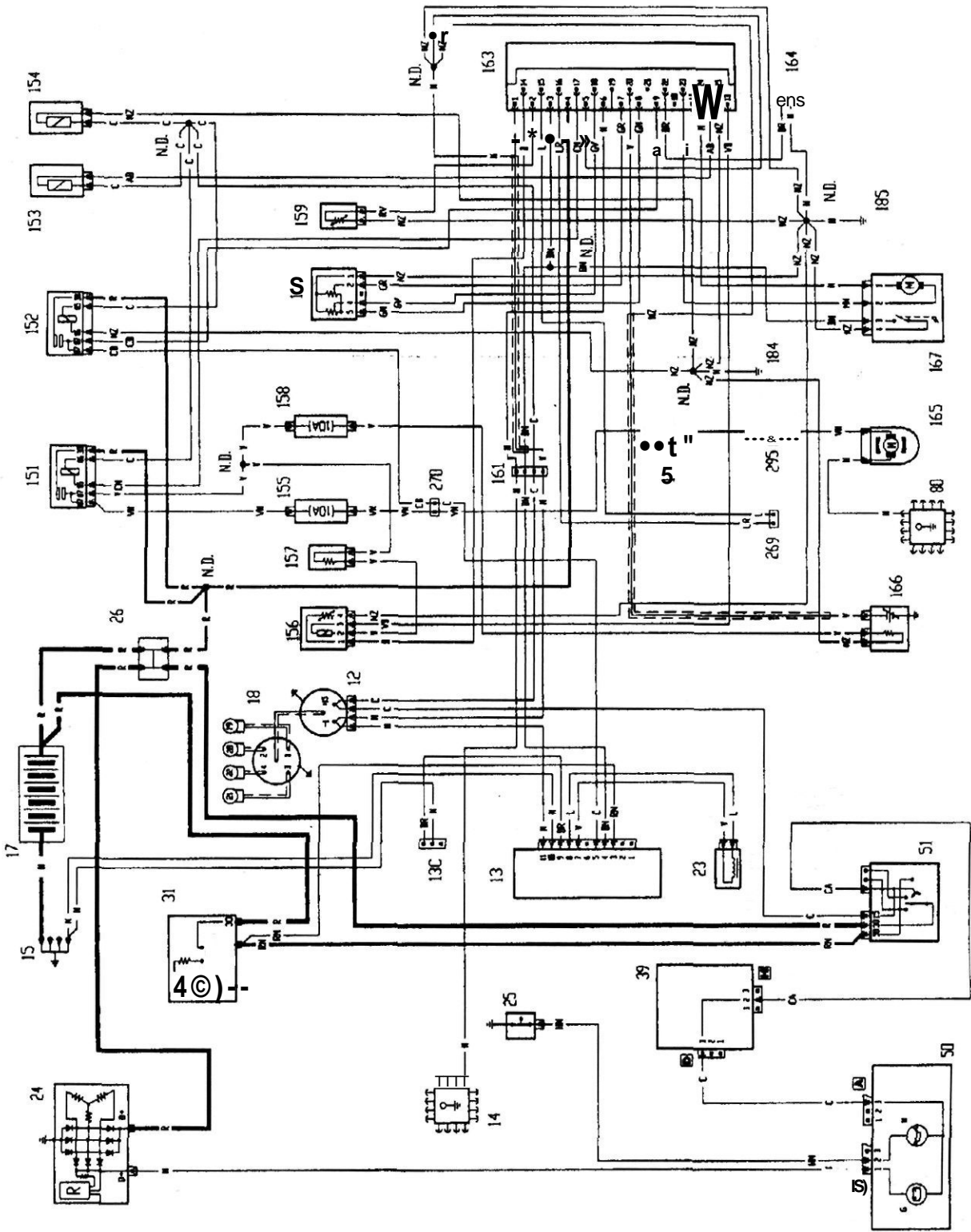
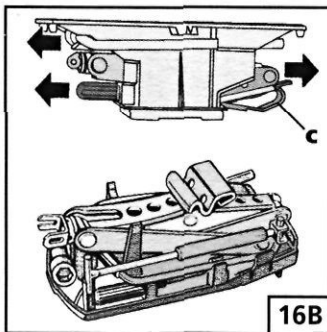
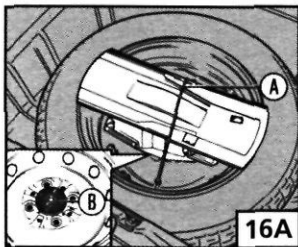

Diagram 4: Model: 1372 i.e. (Super) - Starting - Digiplex Electronic Ignition - Bosch SPI Electronic Injection - Charging - Oil Pressure Warning Light



To release the spare wheel, jack and tool kit:

16A. Undo strap A to release the jack from the support. Unscrew nut B, to remove the spare wheel.

16B. Release the jack from the tool stand by lifting tab C. The arrangement of the tools in their holder might have one of the configurations shown in illustration **16B**.

• 17. RAISING THE VEHICLE

17A. To raise the vehicle, position the jack under the side member, about 20 cm from the wheel arch. Turn the jack handle until the its grooved head (see *inset*) fits the flange at the base of the sill.

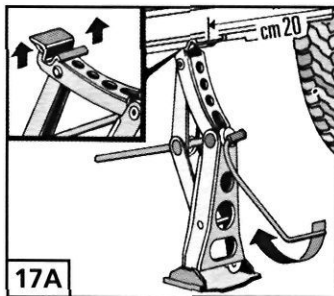

REMOVING A WHEEL

17B. Loosen all the wheel bolts in the order shown.

- Lift the car until the wheel is about 25 mm (1 in.) off the ground.
- The hub cap is secured by only three wheel bolts.
- Remove the hub cap, then unscrew the fourth wheel bolt, and remove the wheel.
- Put the spare wheel on, making sure that the aligning peg or pegs on the hub fits into the hole/s in the rim.
- Attach the wheel with a single bolt and then put the wheel cover back on so that the largest hole fits over the bolt holding on the wheel. Screw in the other three bolts, which also hold on the wheel cover.
- Lower the car and remove the jack. Tighten the wheel bolts evenly in a criss-cross fashion, as shown in illustration **17C**.

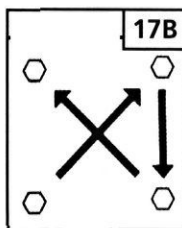

RAISING THE VEHICLE WITH A TROLLEY JACK

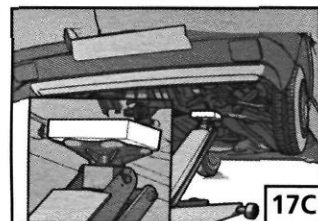

• 17C. FROM THE FRONT - Place a hardwood board between the jack and the car, see inset. The jack must ONLY be positioned under the gearbox case support on the side of the differential gears.

• 17D. FROM THE REAR - Put a hardwood board between the jack and the car ONLY at the back of the spare wheel housing.

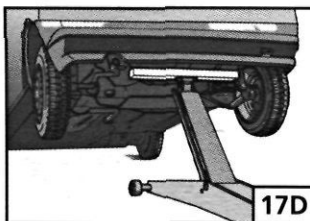

EMERGENCY STARTING

J 18. ENGINE STARTING

JUMP STARTING YOUR CAR

Choose a fully charged battery with the same or higher capacity than the flat battery in your car, then . . .

- Make sure that the car with the flat battery's electrical equipment has its ignition turned OFF, and that the ignition keys are removed.

18. • Connect one of the jump lead clamps to the positive battery post of your flat battery. Then clamp the other end of the same lead on to the positive post of the second (charged) battery.

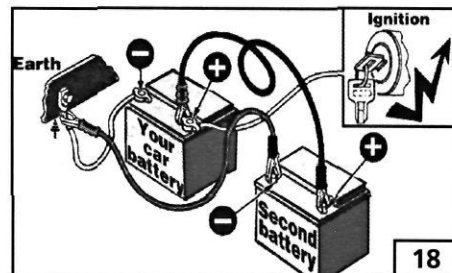

- Connect one end of the second jump lead to the negative pole of the charged battery, and attach the other end to the metal terminal (as shown) of the earth cable from your car's flat battery.
- Run the engine of the car with the charged battery at a medium to slow speed.
- Start the engine of the car with the flat battery, and run the engines of both cars for about three minutes.
- To reduce voltage peaks when disconnecting the jump leads, turn on the air fan and the heated rear screen of the car that had the flat battery.
- Remove the jump leads, starting with the negative clamp connected to the car with the flat battery's earth.

IMPORTANT NOTE: When disconnecting the jump leads DO NOT switch on the headlights in place of the heated rear screen, as the peak voltage may blow the headlight bulbs.

BUMP STARTING YOUR CAR

IMPORTANT NOTES: 1) Never bump start a car fitted with a catalytic converter, as the sudden rush of unburnt fuel into the catalytic converter could damage the converter beyond repair.

2) On models fitted with automatic transmission bump starting is not possible.

3) Ensure that the key is in the ignition and is turned to MAR while the car is being pushed, or the steering wheel will lock.

To bump start a car:

- Place the key in the ignition and turn to MAR.
- Engage a medium gear (2nd or 3rd), NOT REVERSE.
- Hold the clutch pedal down while someone pushes.
- When the pushed car has reached a fair speed, with the car still in gear, release the clutch pedal.
- The engine should now turn over and start running. Depress the clutch and keep the car running.

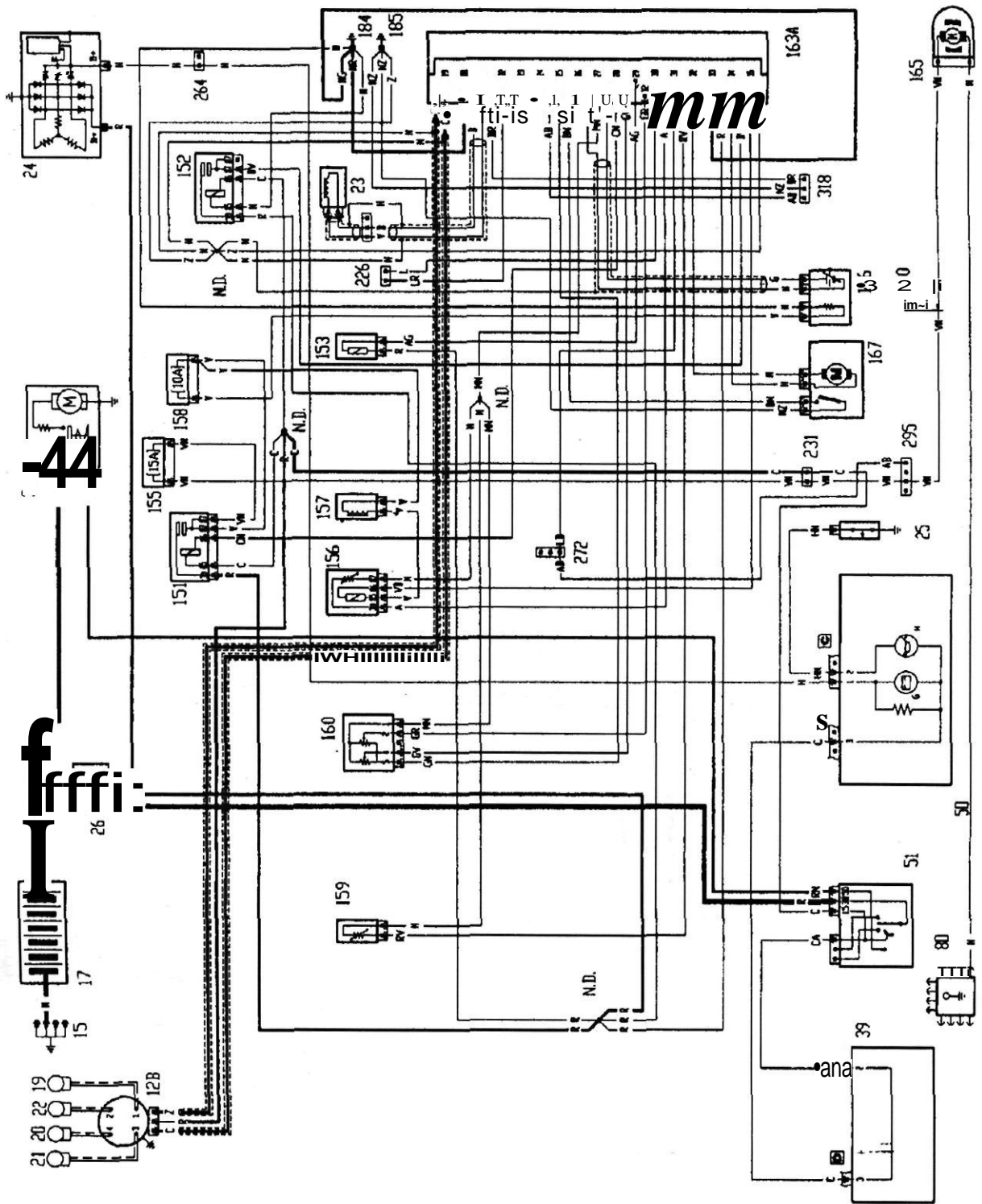

Diagram 5: Model: 1580 i.e. (Version S) - Starting - Bosch Electronic Ignition and Injection - Charging - Oil Pressure Warning Light

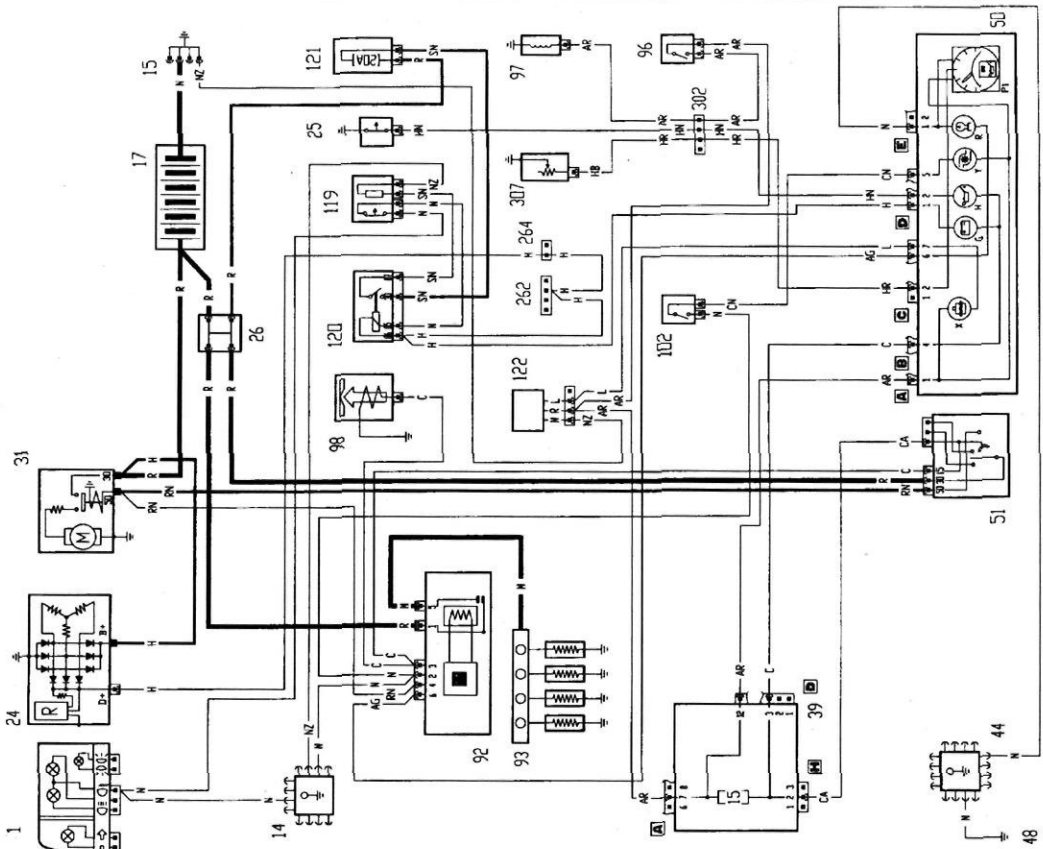

Diagram 6: Model: 1929 Turbo Diesel (SX-GT) - Starting - Charging - Plug Preheating System and Warning Light - Heated Fuel Filter - Automatic Cold Injection Advance Device - Oil Pressure Warning Light - Water in Fuel Filter Warning Light - Turbocharger Pressure Gauge
 NB - Items 262, 264, 307, 97, 102, 302 and 96 not fitted to non-GT models. Items 25 and 50 joined by HN Cable via Item 264.

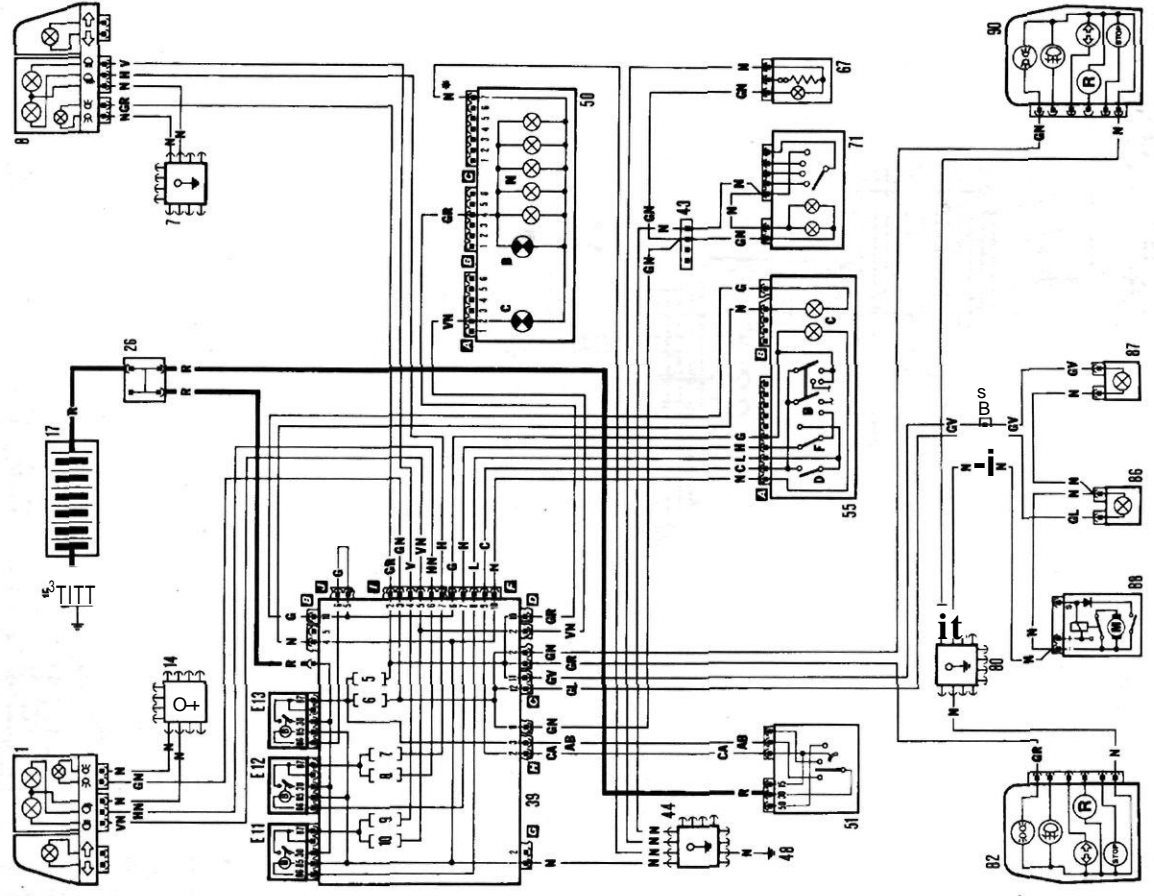

Diagram 7: Models: 1100 -1400 -1697 Diesel - Parking Lights and Warning Light - Dipped Beam Headlights - Main Beam Headlights and Warning Light - Headlight Flasher - Number Plate Lights - Instrument Panel Lights

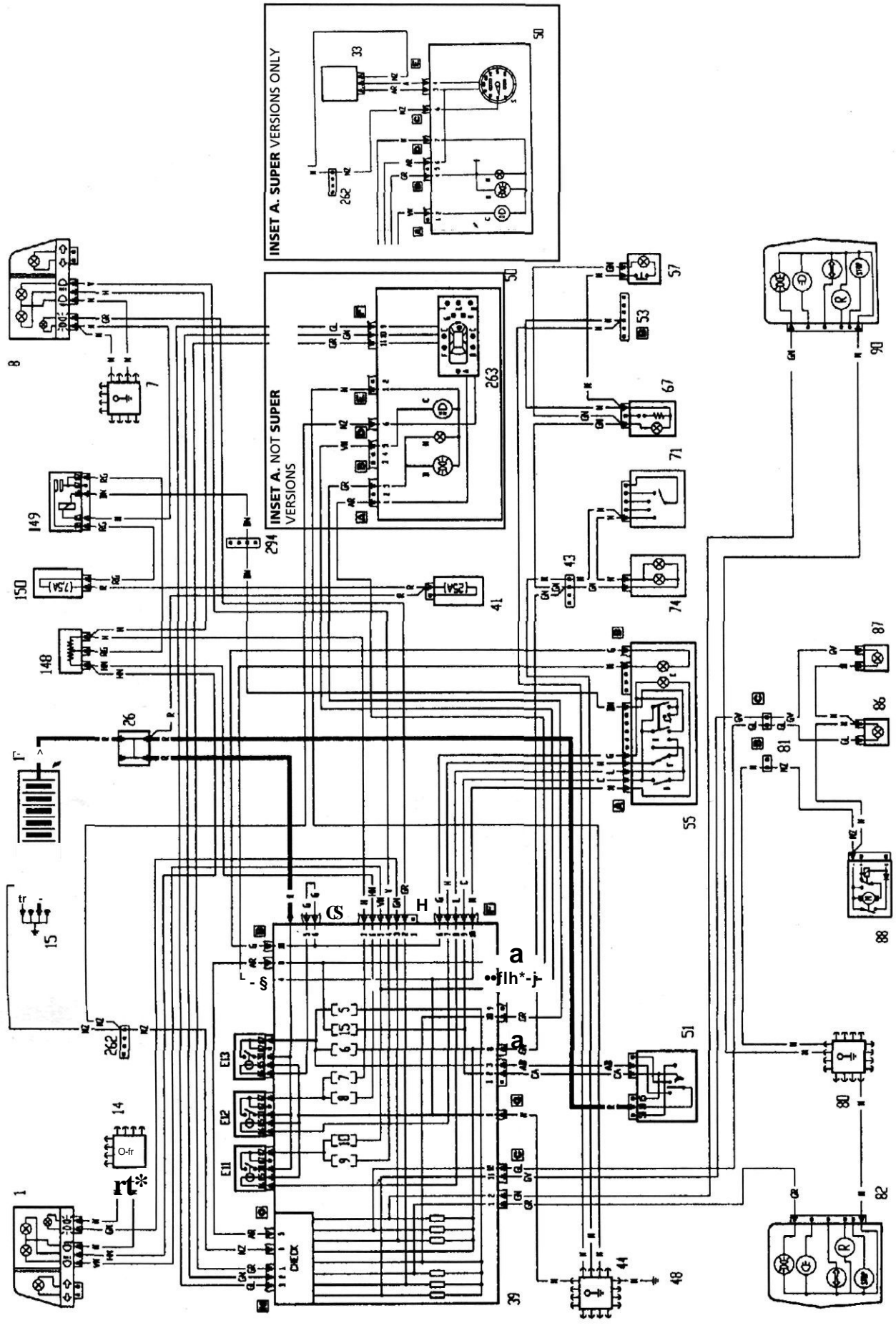
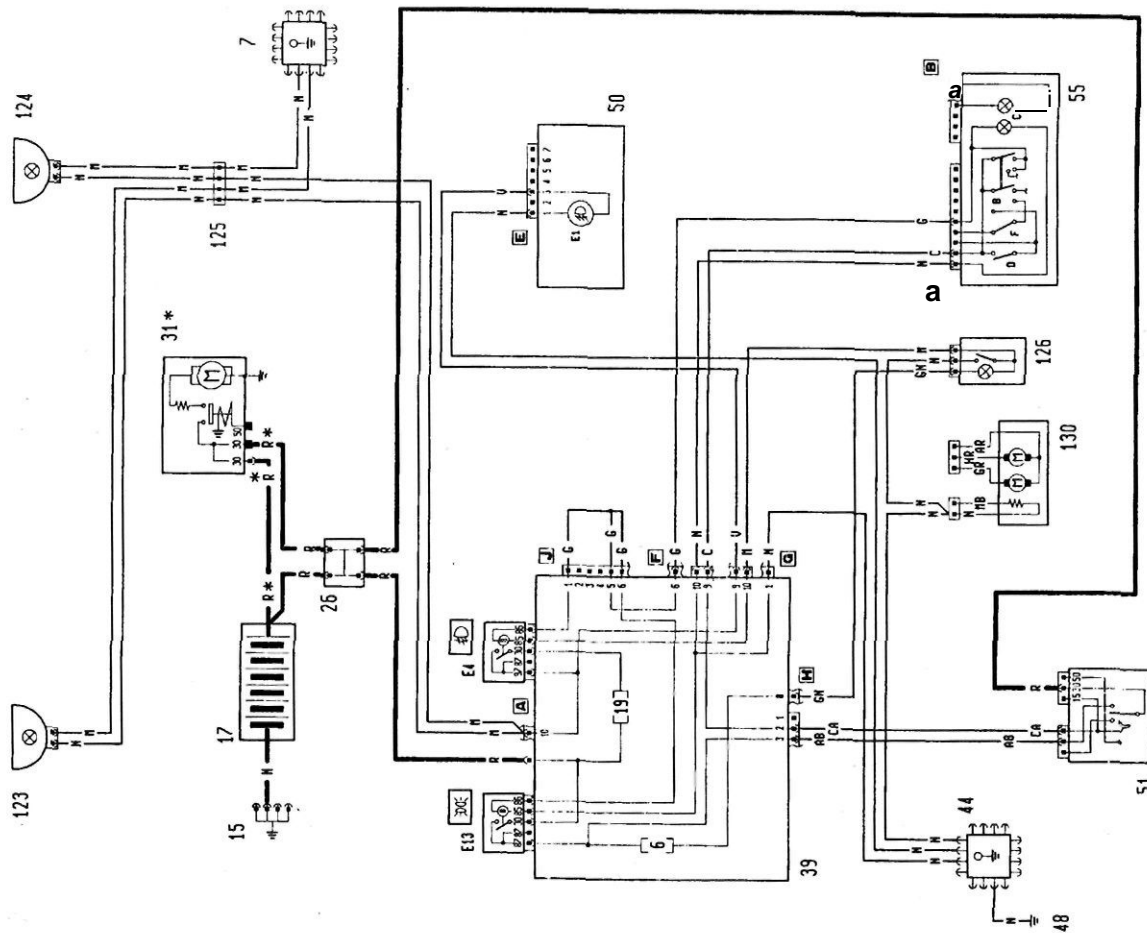

Diagram 8: Models: ('93 Range) Ireland/United Kingdom Versions: Super - SX and SXL - Parking Lights and Warning Light - Dipped Beam Headlights - Dim/Dipped Headlights - Main Beam Headlights and Warning Light - Headlight Flasher - Number Plate Light - Speedometer - Instrument Panel Lighting
 NB - GT, S and SXL versions do not have items 148, 150, 149, 294 and 41.



* Variant connection for 1750 engine

Diagram 9: Models: S - SX - SXL - GT Versions (with EEC STAGE 2 Engines) - Front Fog Lights and Warning Light

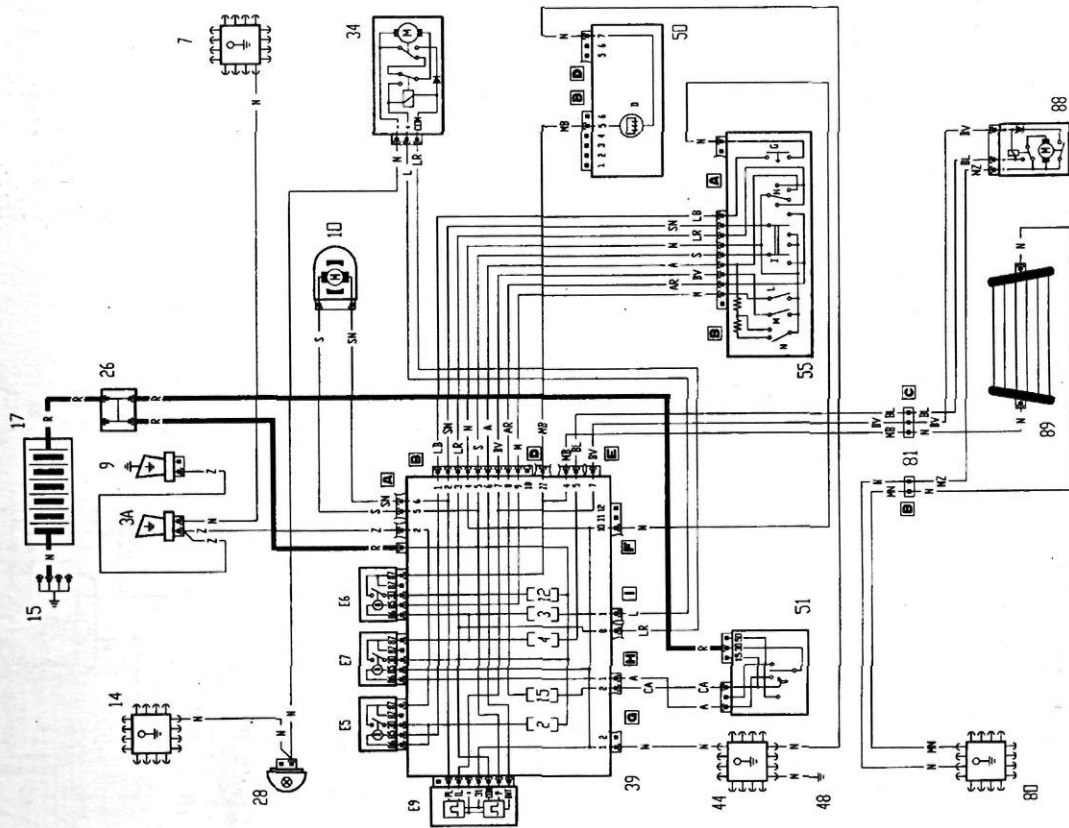

Diagram 10: Models: ('93 Range) - Windscreen Wiper - Rear Wash/Wipe - Windscreen and Rear Window Washer Pump - Electric Horns - Heated Rear Window and Warning Light

NB - On SXL and GT Versions, HB cable joins item 50 at contact 2 Block A and is connected to N Cable at contact 1, Block D (shown as contact 5 on this drawing but 1 on SXL/GT cars)

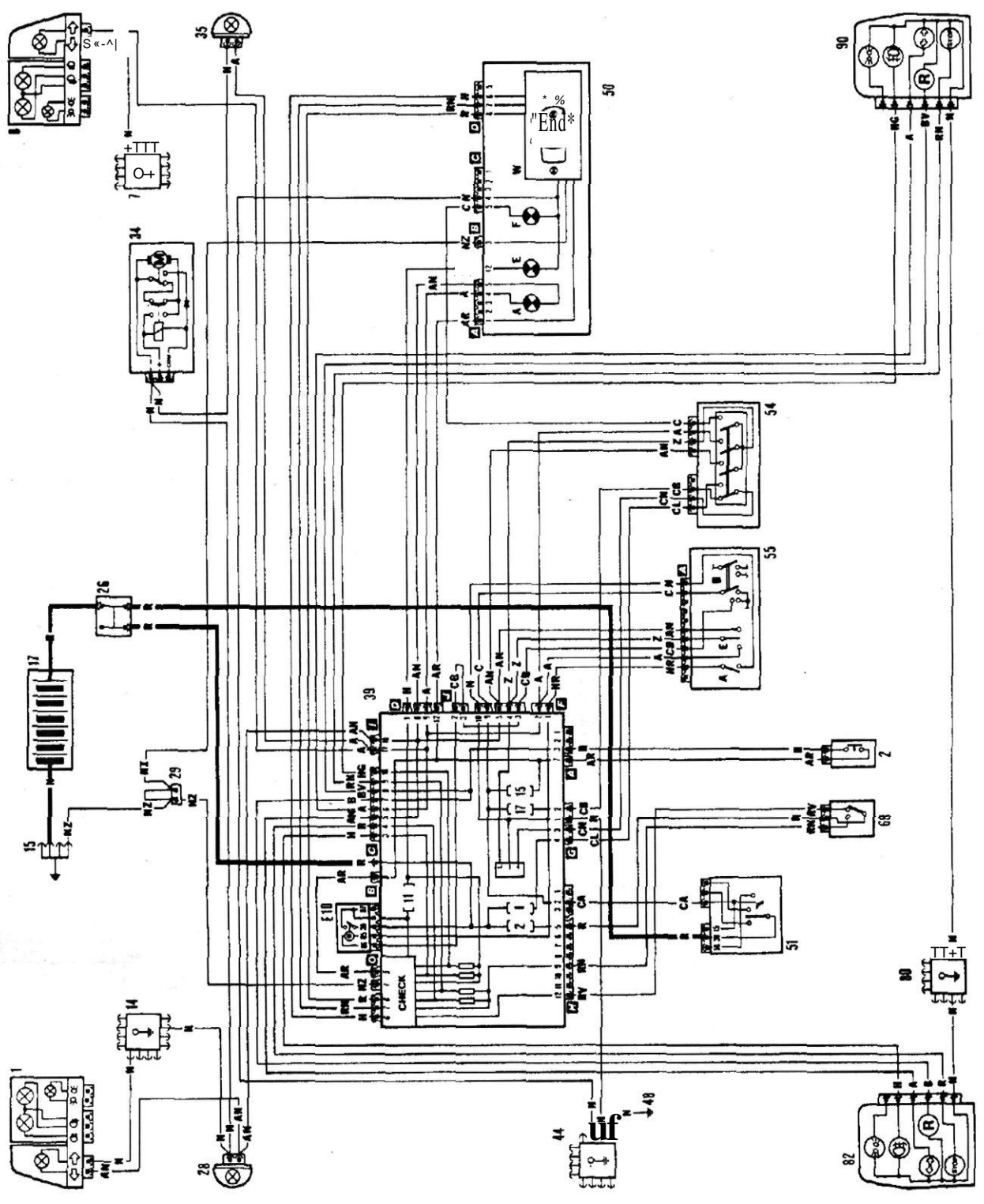

Diagram 11: Model: DGT- Rear Fog Lights and Warning Light- Reversing Lights- Direction Indicators and Warning Light - Hazard Flashers and Warning Light - Brake Lights

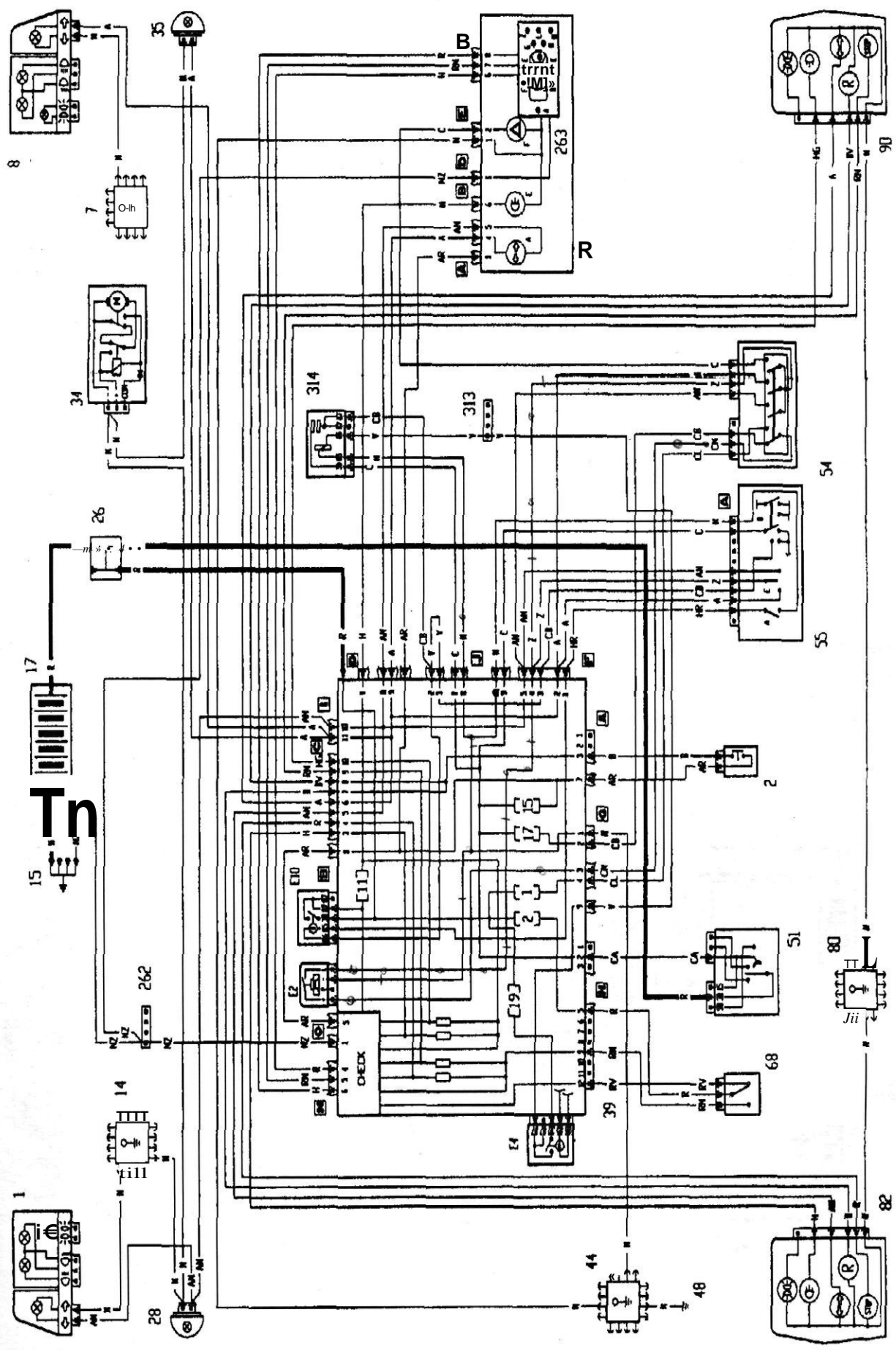

Diagram 12: Models: GT-SXL Petrol - Direction Indicators and Warning Light - Hazard Flashers and Warning Light - Rear Fog Lights and Warning Light - Reversing Lights - Brake Lights
 NB - SX Versions do not have items 34, 314 and 313.

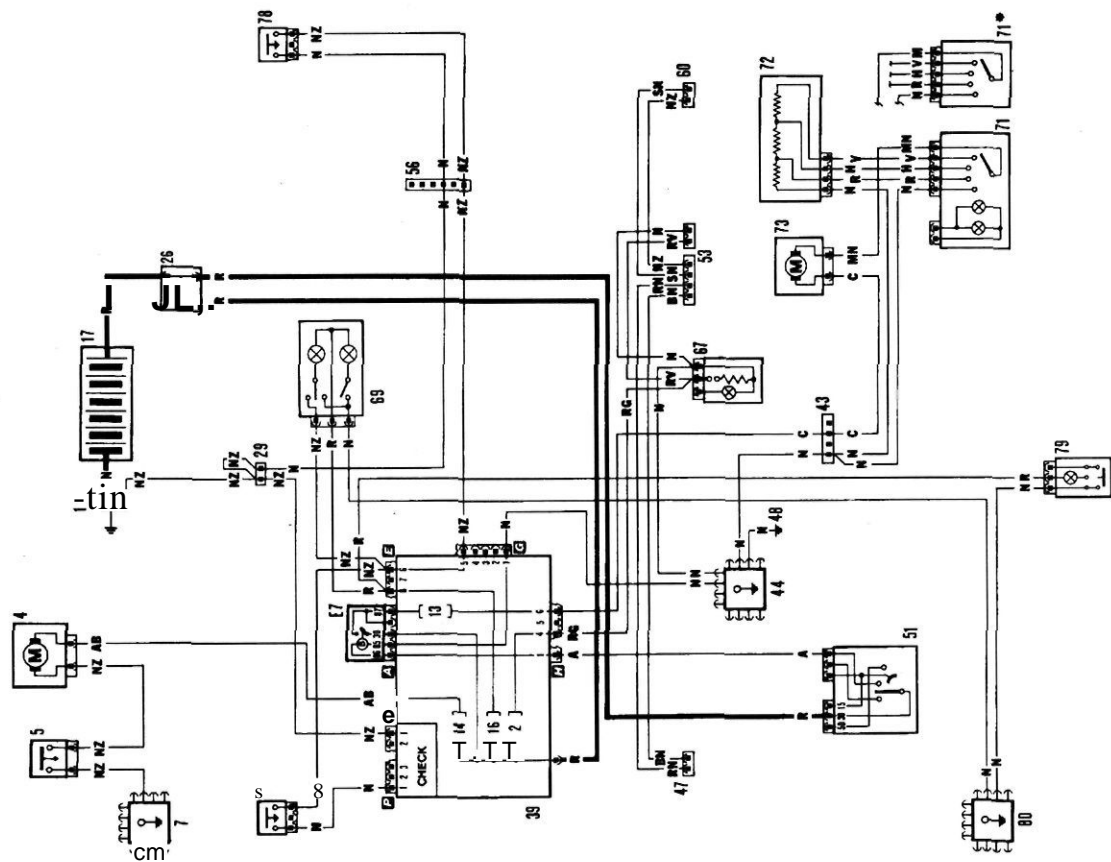

Diagram 13: Models: DGT1100 -1400 and 1600 - Engine Radiator Cooling - Car Interior Ventilation - Available for Radio - Cigar Lighter - Courtesy Light

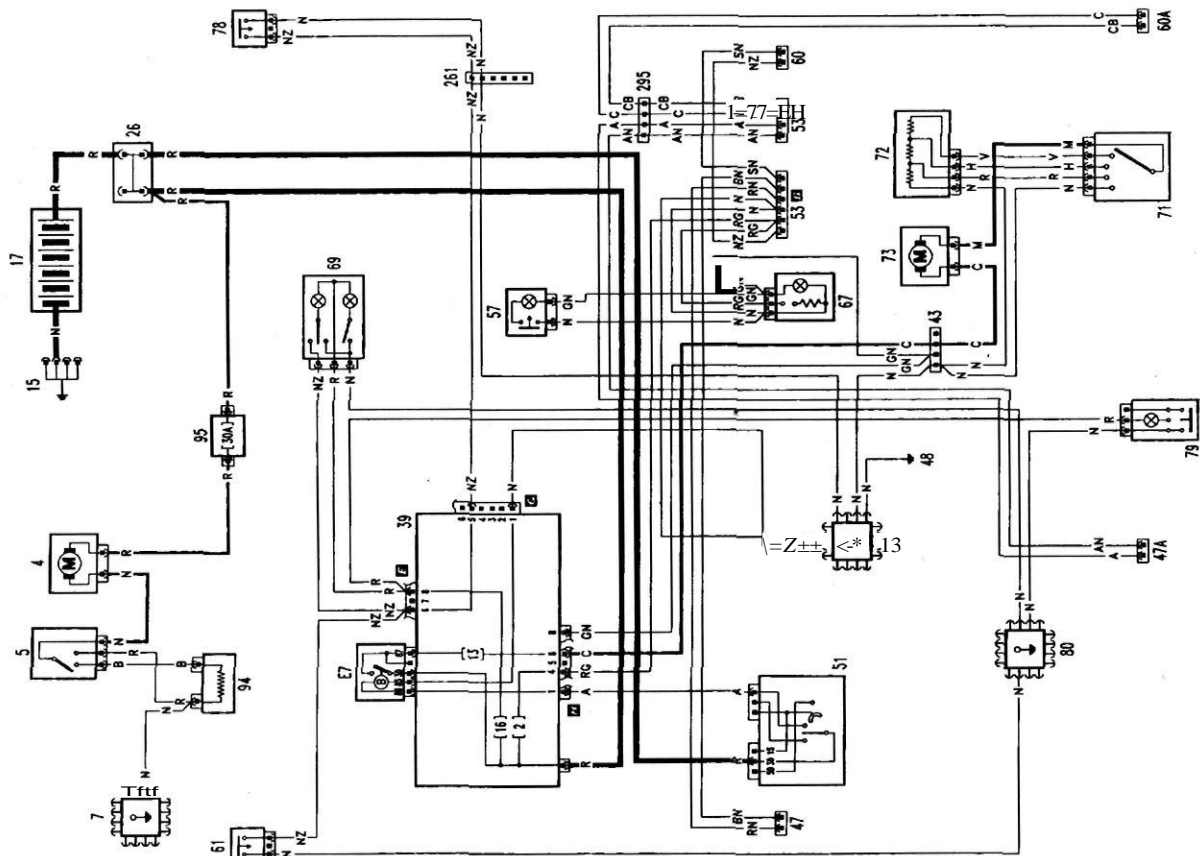

Diagram 14: Model: 1697 Diesel ('93 Range) Super - Engine Cooling System - Car Interior Ventilation - Provision for Car Radio - Cigar Lighter - Courtesy Light
 NB - Early/non-Super models similar, but no items 47A, 295, and 60A. Item 95 has 40A fuse on DGT Models

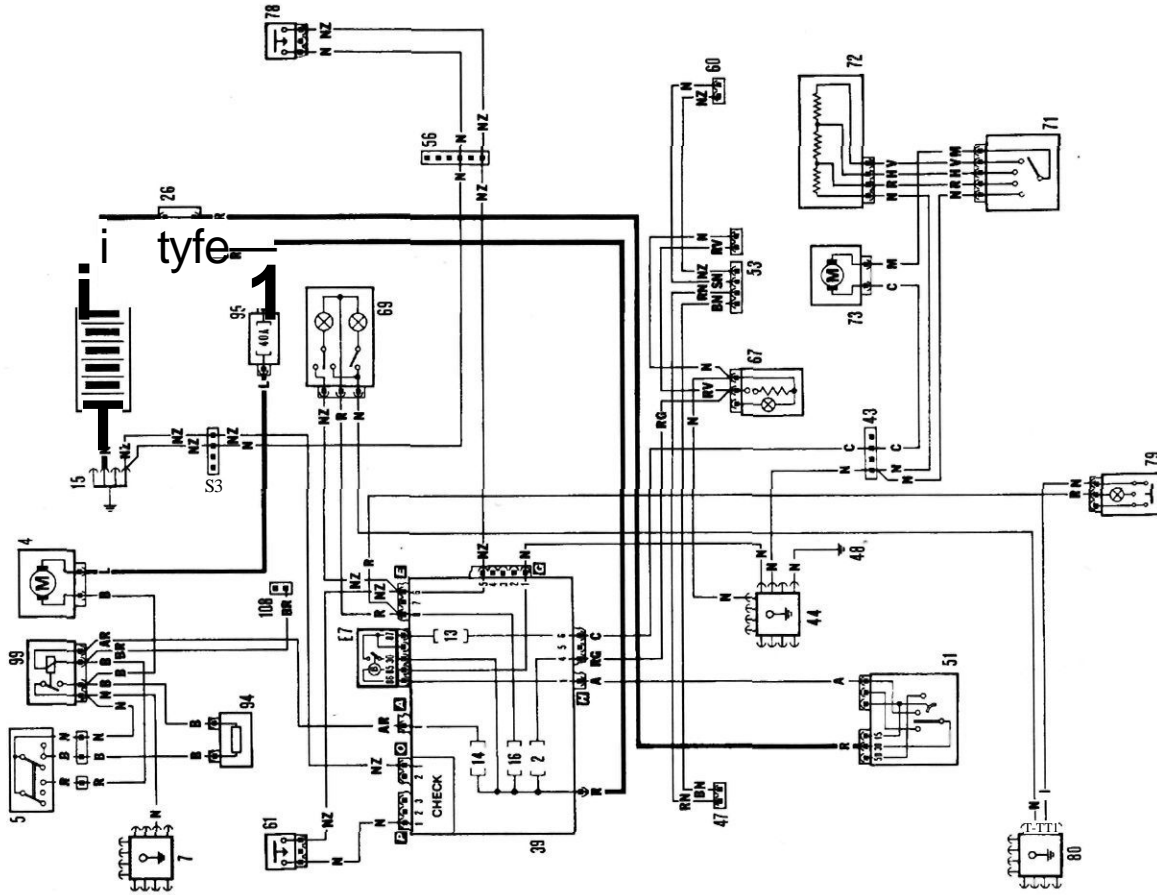

Diagram 15: Model: 1930 Turbo Diesel DGT - Engine Radiator Cooling - Car Interior Ventilation - Available for Radio - Cigar Lighter - Courtesy Light

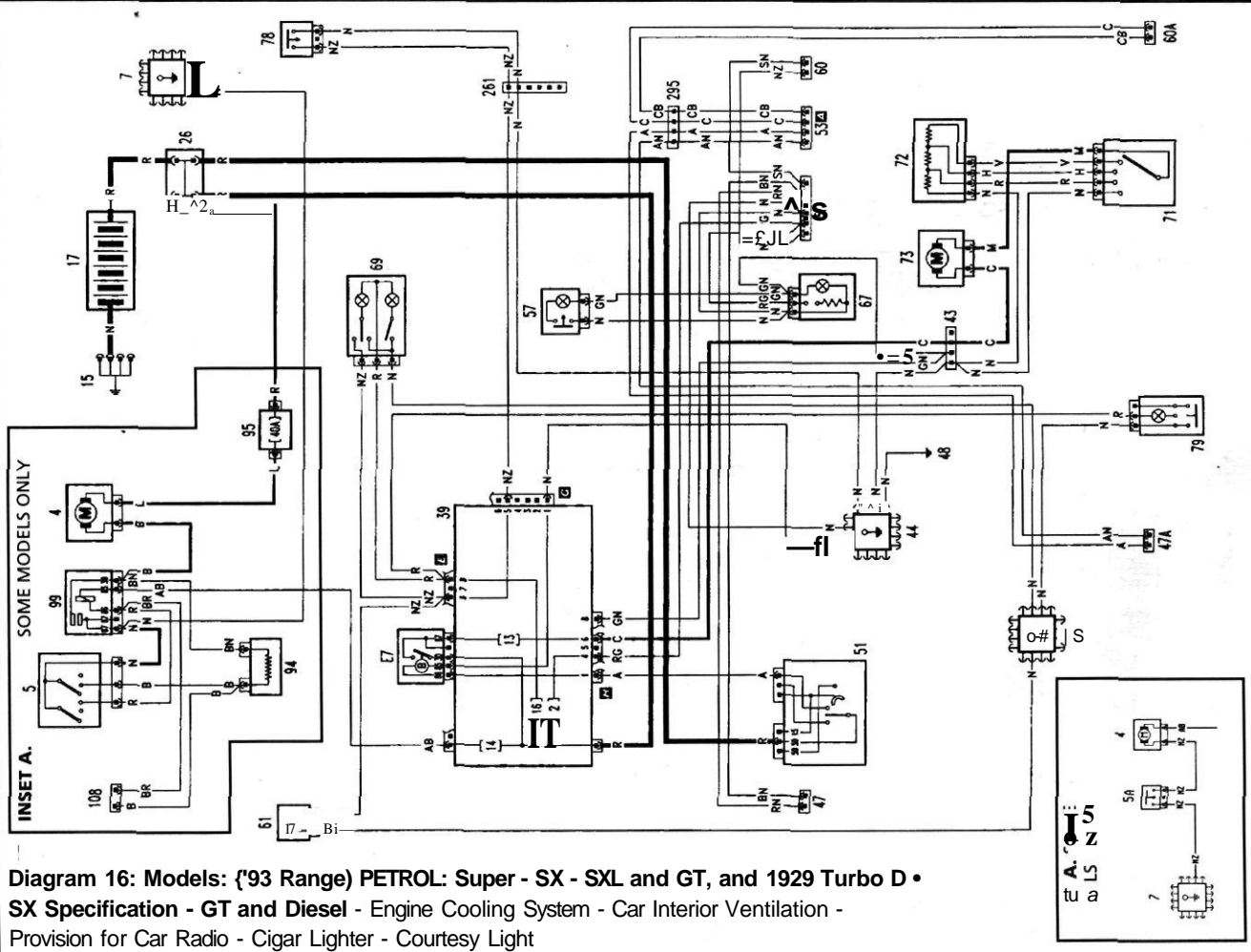

Diagram 16: Models: ('93 Range) PETROL: Super - SX - SXL and GT, and 1929 Turbo D • SX Specification - GT and Diesel - Engine Cooling System - Car Interior Ventilation - Provision for Car Radio - Cigar Lighter - Courtesy Light

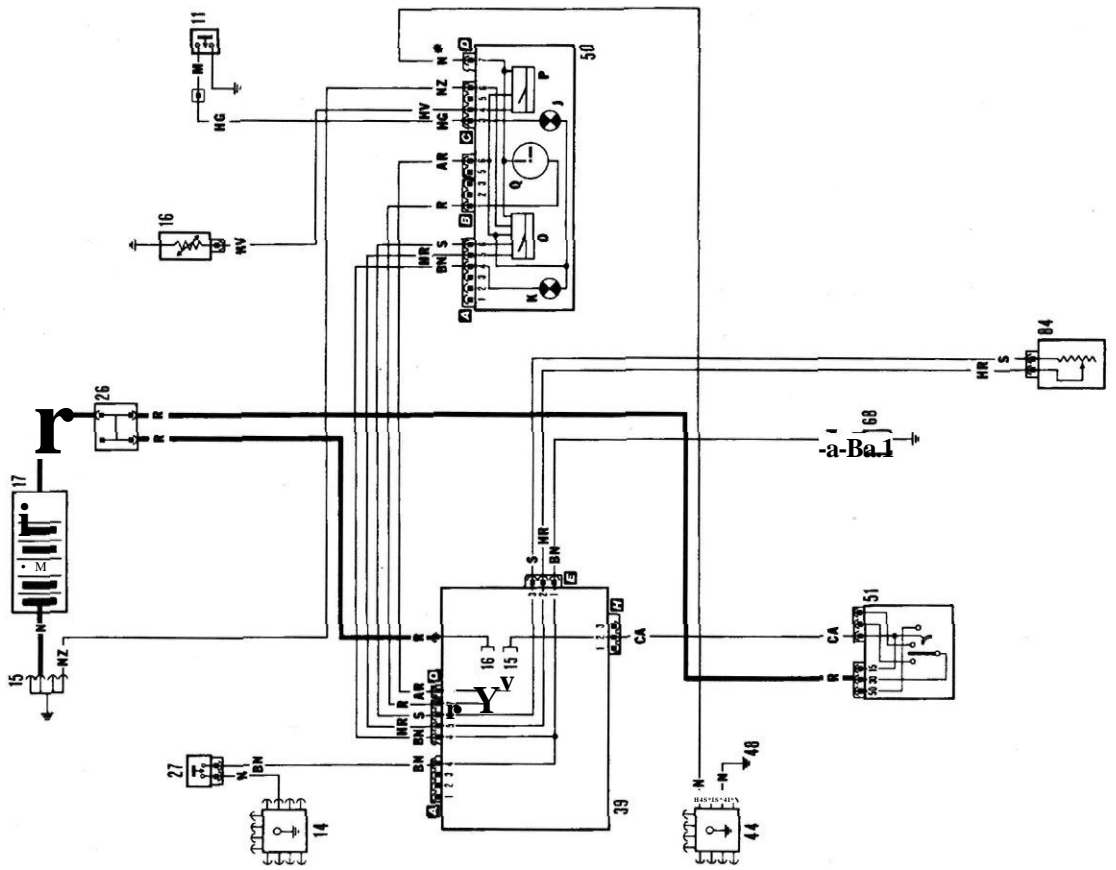

Diagram 17: Models: 1100-1400-1697 Diesel- Fuel Gauge- Low Brake Fluid Level and Handbrake Warning Light-Water Temperature Gauge - Brake Pad Wear Warning Light - Clock

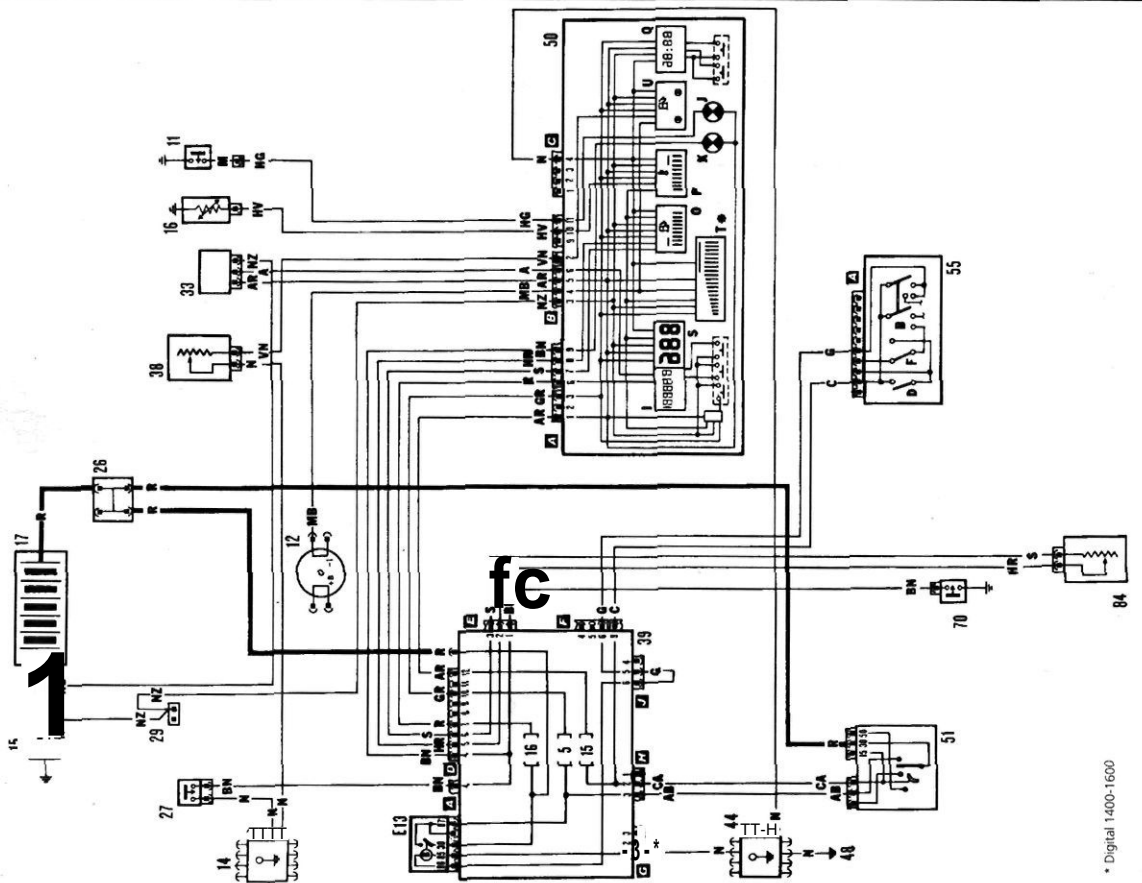
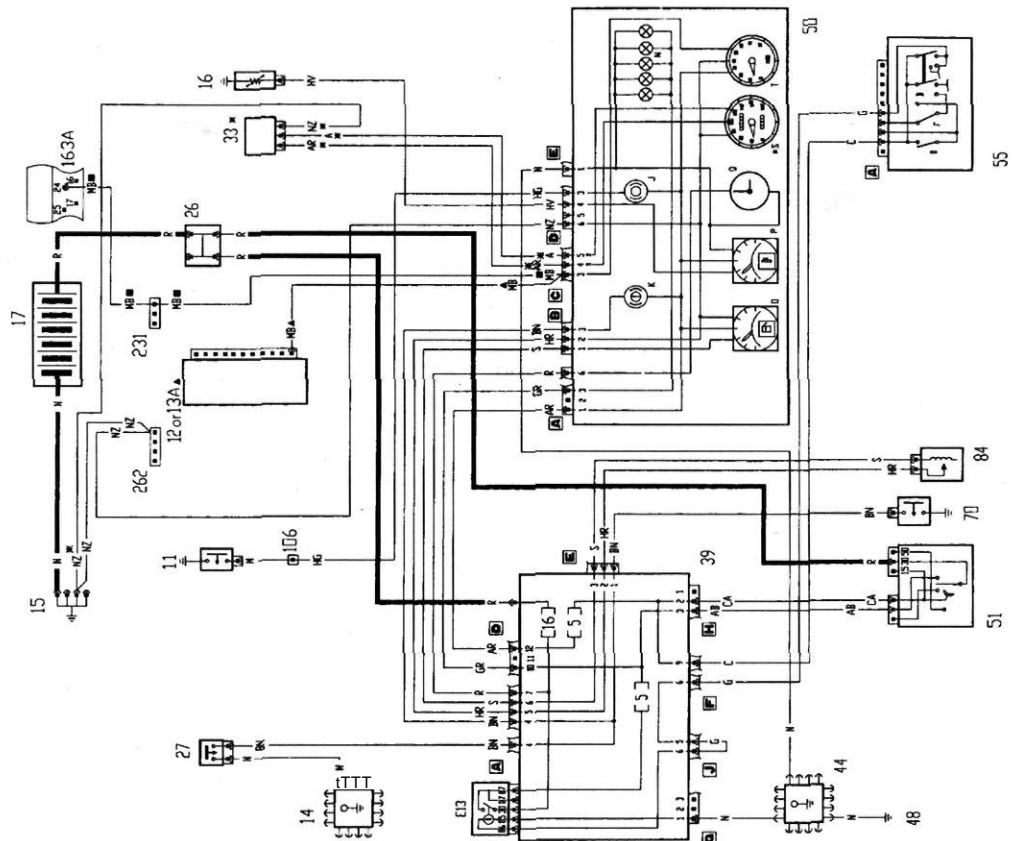

Diagram 18: Models: 1100-1400-1600- Fuel Gauge- Econometer- Low Brake Fluid Level and Handbrake Warning Light - Water Temperature Gauge - Brake Pad Wear Warning Light - Clock - Speedometer - Tachometer - Instrument Illumination

* Digital 1400-1600



■ Only on versions Ireland / United Kingdom
 ▲ Only for version 1580 i.e.
 ▲ Only on versions 1580 i.e. A.T. CTX - 1372 i.e.

Diagram 19: Models: ('93 Range) - GT - SX and SXL (Petrol) - Fuel Level Gauge - Low Brake Fluid Level and Handbrake Warning Light - Water Temperature Gauge - Excessive Brake Pad Wear Warning Light - Clock - Speedometer - Rev. Counter - Instrument Panel Lighting

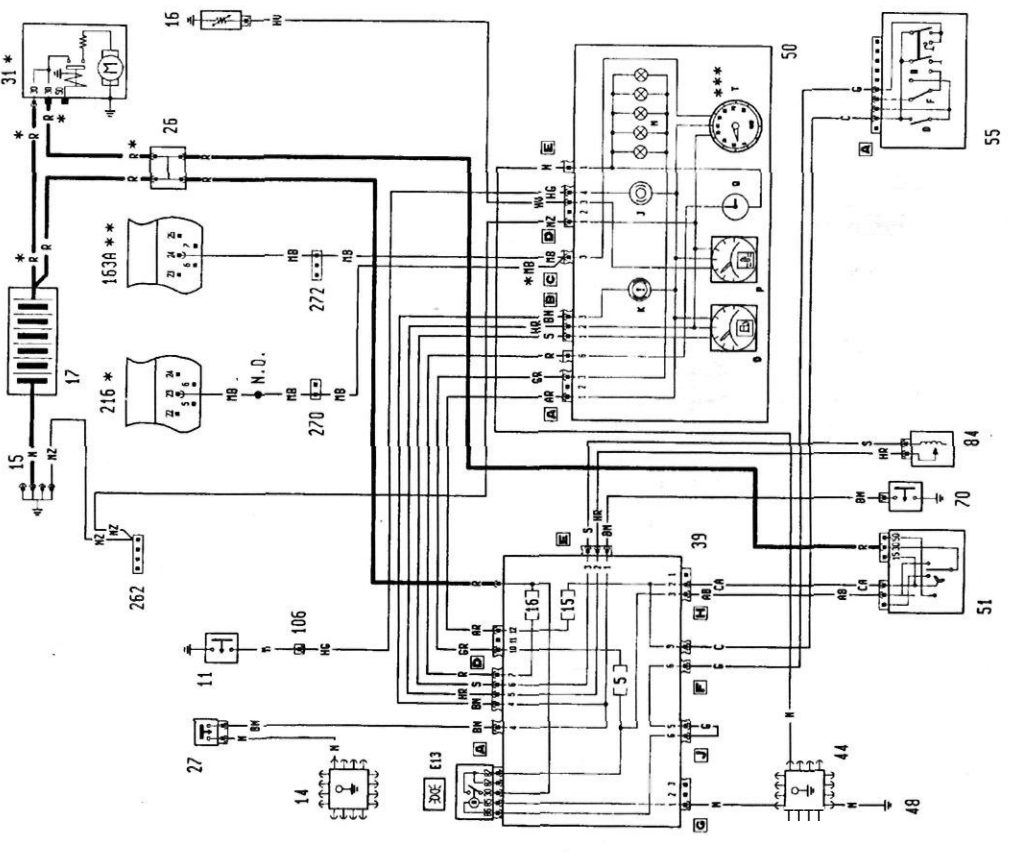

* Variant connection for 1750 version
 ** Variant connection for 1372 version
 *** Not present on S version

Diagram 20: Models: S - SX - SXL and GT (with EEC STAGE 2 Engines) - Fuel Level Gauge and Reserve Warning Light - Low Brake Fluid Level and Handbrake On Warning Light - Water Temperature Gauge - Brake Pad Wear Warning Light - Analogue Clock - Electronic Rev. Counter

CHAPTER 3 FACTS AND FIGURES

This chapter provides you with all the information you will need about your car, especially in connection with servicing and repairing it. First, you'll need to identify the engine type. If you don't know it already, see **Chapter 6, Repairs and Replacements.**

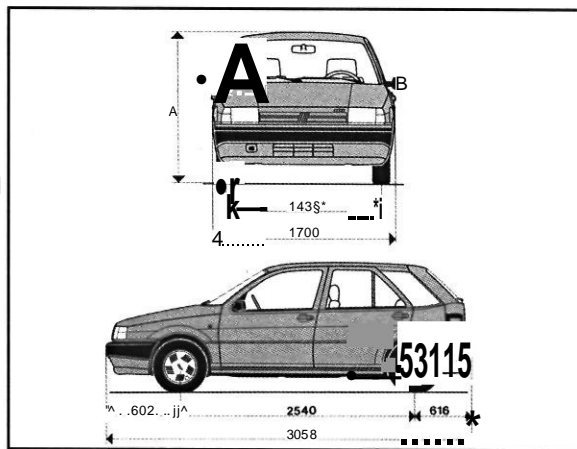

Before buying parts, be sure to take your vehicle's chassis and engine numbers with you - see **Auto-Biography** on **page 1** and **PART G: IDENTIFICATION NUMBERS** in this chapter.

Chapter Contents

| | Page No. | | Page No. |
|--------------------------|----------|--------------------------------|----------|
| PART A: MAJOR MILESTONES | 17 | PART E: REPAIR DATA | 20 |
| PART B: VITAL STATISTICS | 18 | PART F: TORQUE WRENCH SETTINGS | 23 |
| PART C: CAPACITIES | 19 | PART G: IDENTIFICATION NUMBERS | 27 |
| PART D: SERVICE DATA | 19 | | |

IMPORTANT NOTE: Many detail changes have taken place over the years, and there have been many different Special Editions and Options available. The following information will be true of most cases but can only be taken as a general guide. Consult your local FIAT dealer for confirmation.

PART A: MAJOR MILESTONES

Overview Although the *Tipo* and *Tempra* were presented as separate models, they are essentially the same cars, with detail differences. However, all *Tipos* are 5-door hatchbacks (apart from some 3-door 1.4 and the relatively rare 2.0 i.e. 16v, both from 1993); all *Tempras* are 4-door saloons (with a boot) or 5-door estates. Apart from the rear bodywork and very slight differences in rear suspension rates, both models are the same, although years of production and options available (including some engine options and some model names) are not necessarily the same, and changes were not always introduced to both model names at the same time - if at all. All models come with front disc, rear drum brakes, except the *Tipo 2.0 i.e. 16v* (but NOT the 2.0 i.e. GT), and the *Tempra 2.0 i.e. SX* and *SIX* models, which have discs front and rear.

IMPORTANT NOTE: This manual does NOT cover 1.8 and 20 litre *Tipo* or *Tempra* models.

June 1988 *Tipo* range introduced, as 1.4, 1.4 DGT, 1.6 DGT and 1.6 DGT5X models with 1372cc and 1580cc petrol engines. Also 1. ST.ds with 1929 turbo diesel engine DGT and Ids with digital instruments. All models with galvanised steel body.

October 1988 *Tipo* 1.7D diesel version launched.

April 1990 *Formula* and 5 versions of *Tipo* 1.4 introduced.

April 1990 Also 1.6 DGT Selecta version introduced with CVT gearbox.

July 1990 *Tempra* 1.4 and 1.6 (petrol) and 1.9D, (non-turbo diesel), and 7.9 TDS and TD5X (turbo diesel) 4-door saloon models introduced. CVT auto-transmission available on 1.6 petrol models only - same as *Selecta* on *Tipo* models, but not named as such. *Tempra* 1.8 i.e. SX with high performance 1756cc double-overhead camshaft (DOHC) fuel-injected engine introduced. *Tempra* 1.4 and 1.6 basic and 5 models with regular, analogue instruments; *Tempra* SX and SX i.e. with digital instruments.

Tipo 1.8 i.e. DGT model, with high performance 1756cc fuel injected, DOHC petrol engine introduced.

June 1991 *Tempra Station Wagon* introduced, as 1.6 or 1.8 i.e. models, with 2-part horizontally split tailgate and high-roof styling.

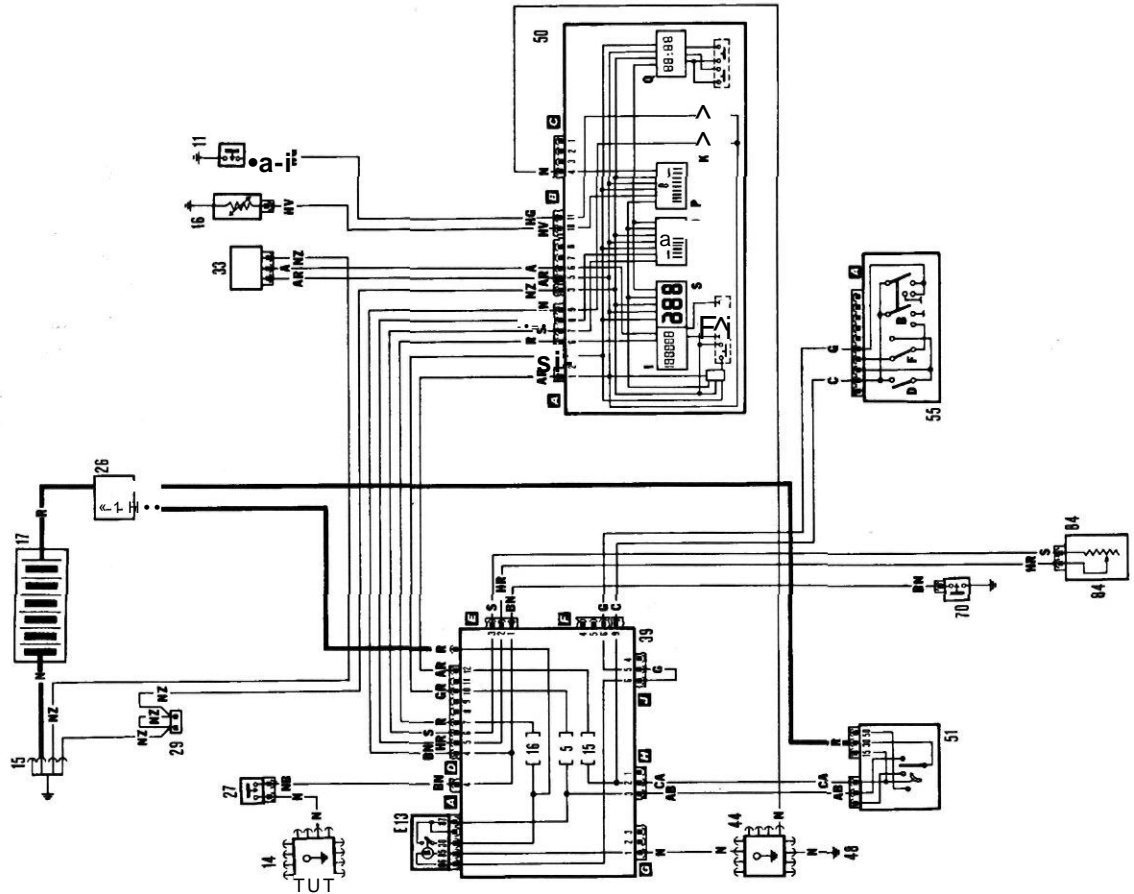

Diagram 21: Model: 1697 Diesel DGT - Fuel Gauge - Low Brake Fluid Level and Handbrake Warning Light - Water Temperature Gauge - Brake Pad Wear Warning Light - Clock - Speedometer - Instrument Illumination

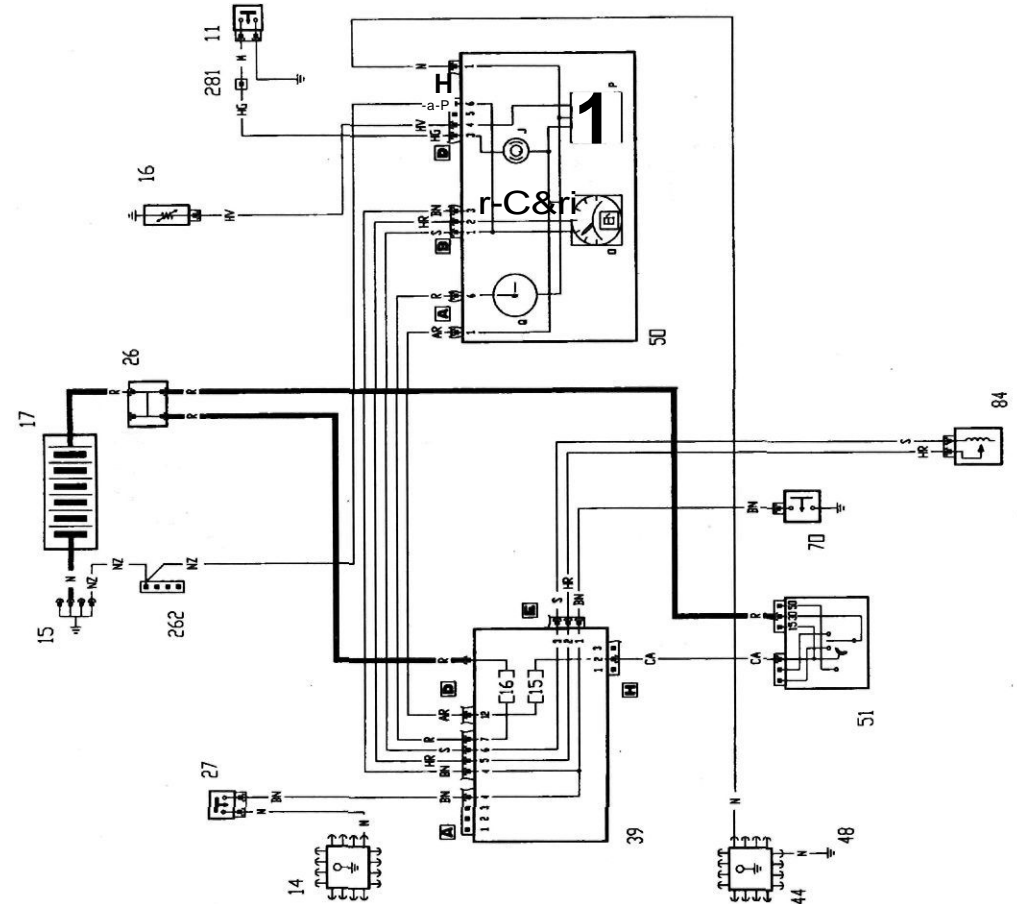

Diagram 22: Model: ('93 Range) 1929 Diesel SX - Fuel Level Gauge - Low Brake Fluid Level and Handbrake Warning Light - Water Temperature Gauge - Excessive Brake Pad Wear Warning Light - Clock - Speedometer Rev. Counter - Instrument Panel Lighting

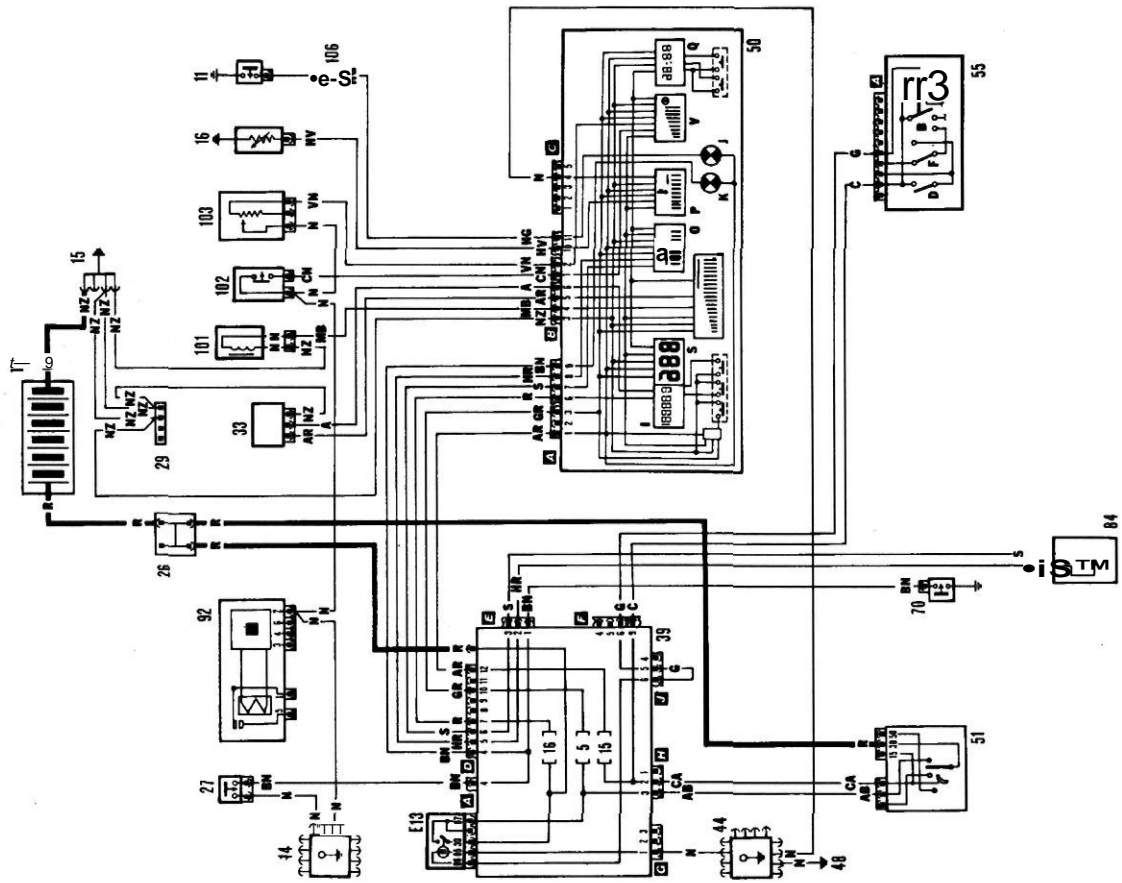

Diagram 23: Model: 1930 Turbo Diesel DGT - Fuel Gauge - Low Brake Fluid and Handbrake Warning Light - Turbocharging Pressure Gauge - Water Temperature Gauge - Brake Pad Wear Warning Light - Clock - Instrument Illumination

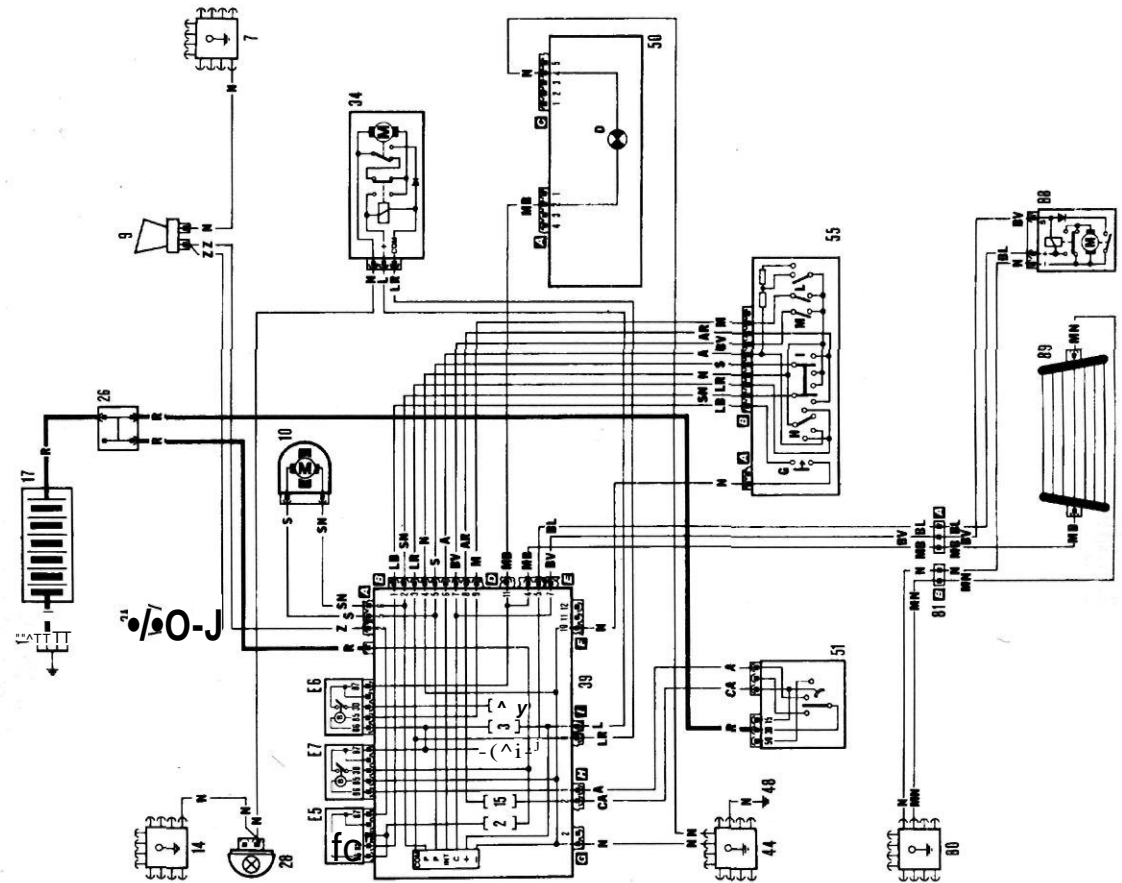

Diagram 24: Model: General - Horn - Heated Rear Window - Windscreen Wiper - Rear Window Wiper - Windscreen/Rear Window Washer Pump
 NB - If your non-DGT vehicle has only one horn, ignore Item 3A

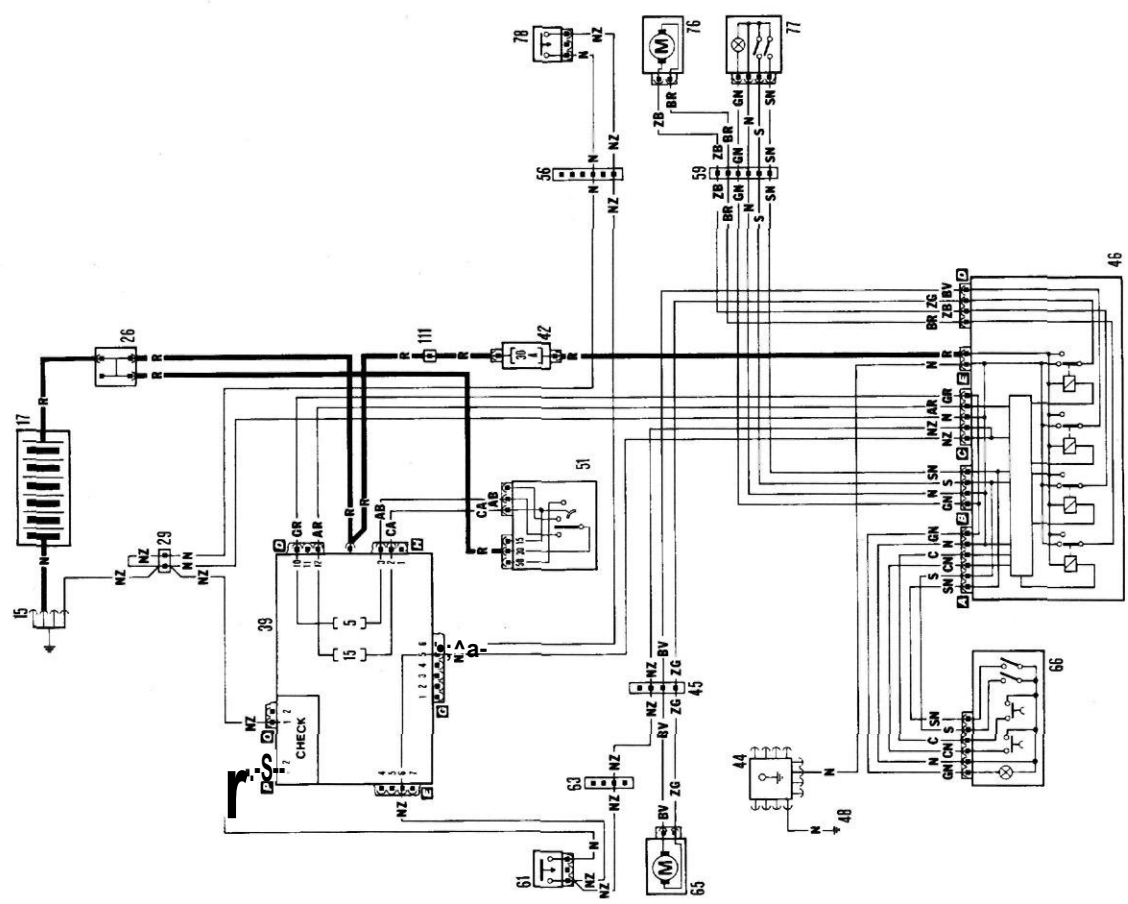

Diagram 25: Model: General (non-EEC STAGE 2 engines) - Electric Front Windows
 NB - Fuse in Item 42 is 25A from 1993-on

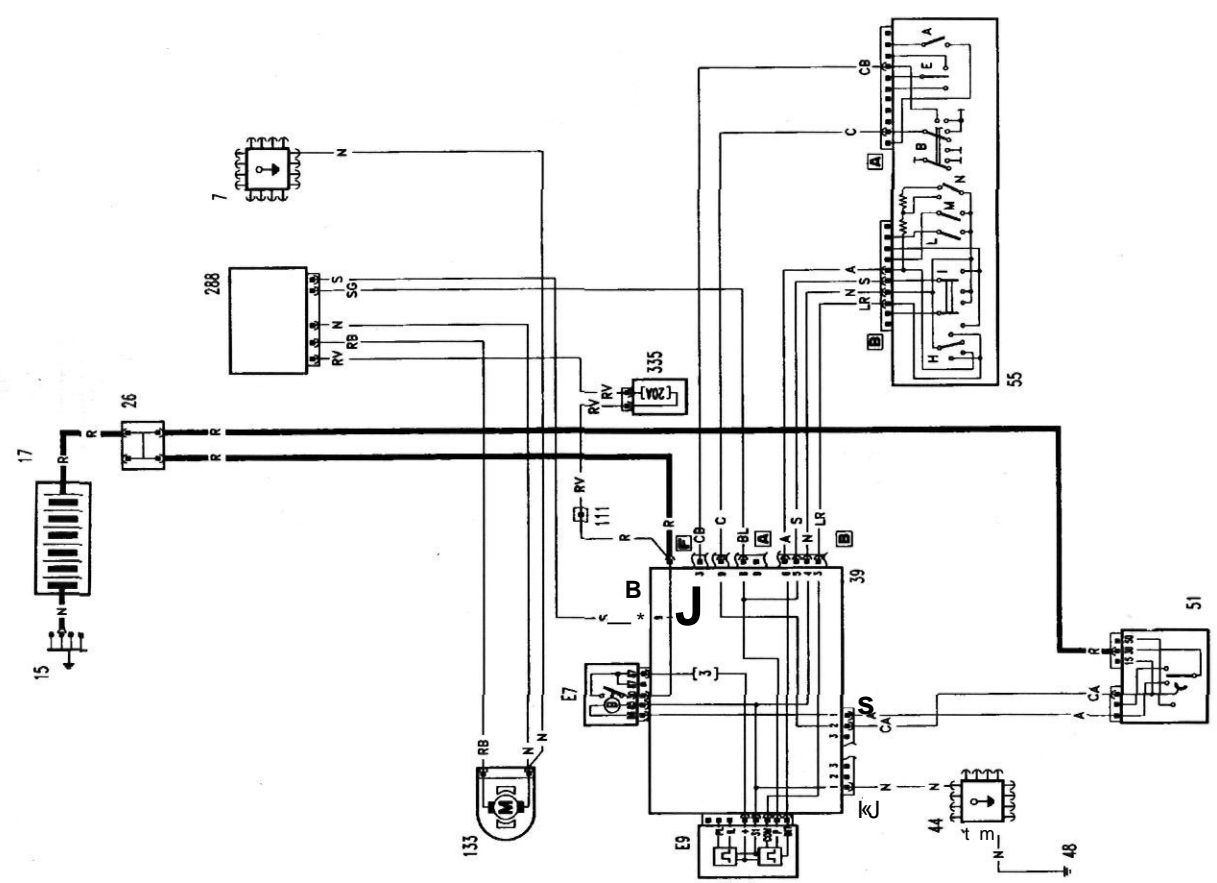
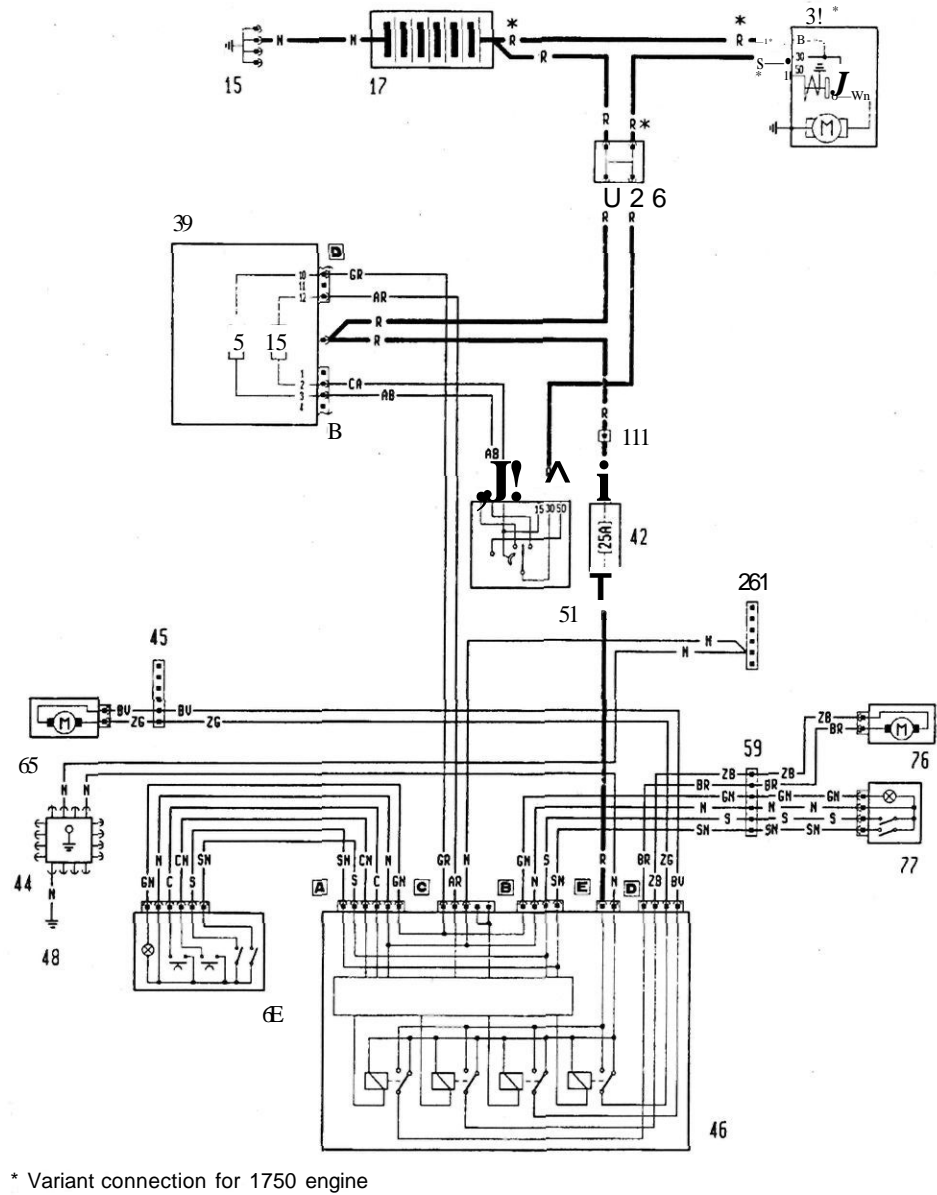
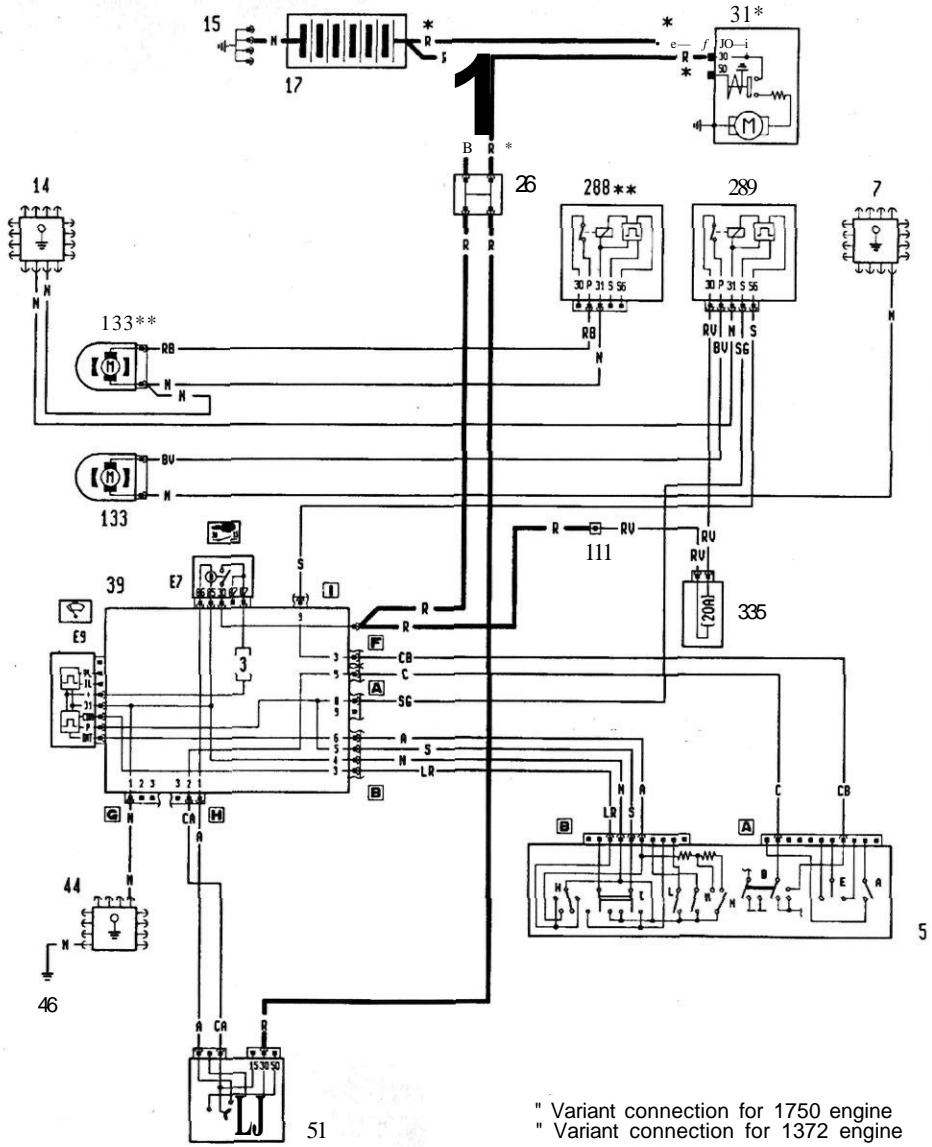
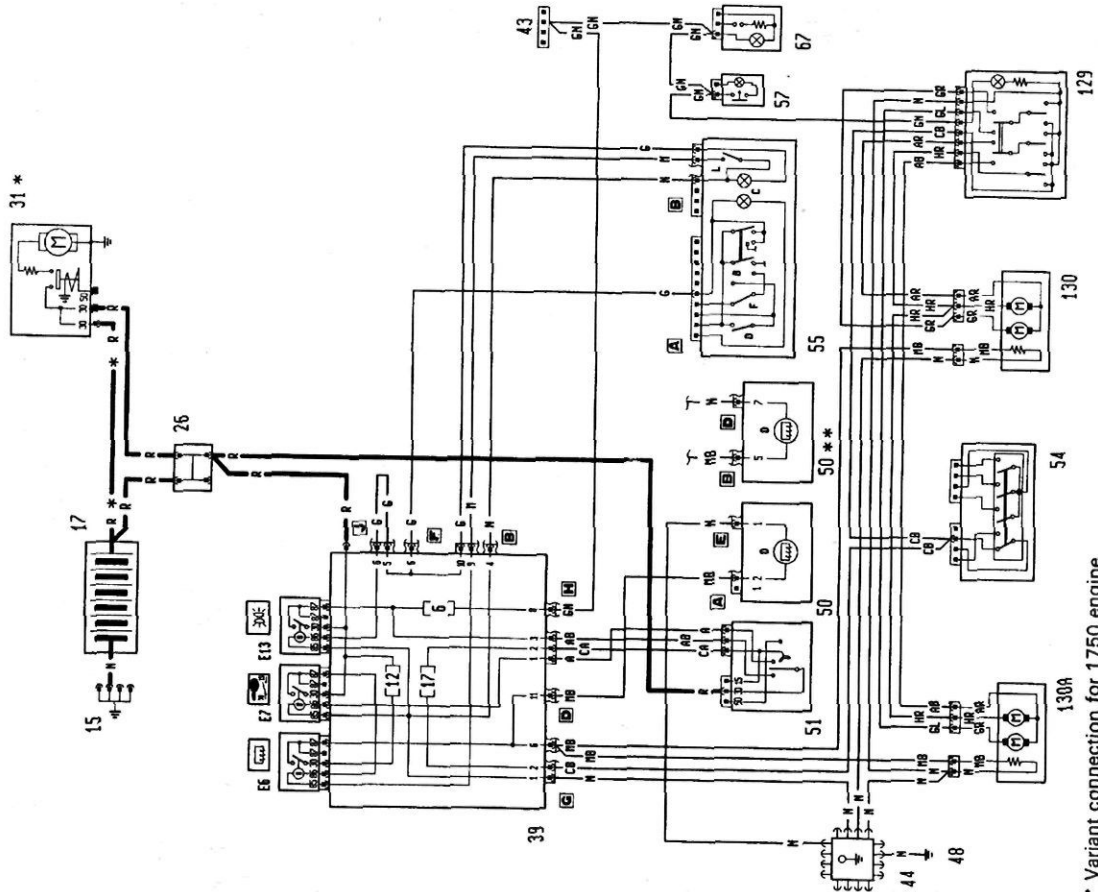

Diagram 26: Models: (93 Range) 1372 i.e. -1580 i.e. -1929 Diesel and Turbo Diesel -1750 i.e. 2000 i.e. SXL - Headlight Washer





• Variant connection for 1750 engine
 ** Variant connection for 2000 engine

Diagram 29: Models: All Types with EEC STAGE 2 Engines Except 1372 S - Electrically Adjustable and Heated External Rearview Mirrors

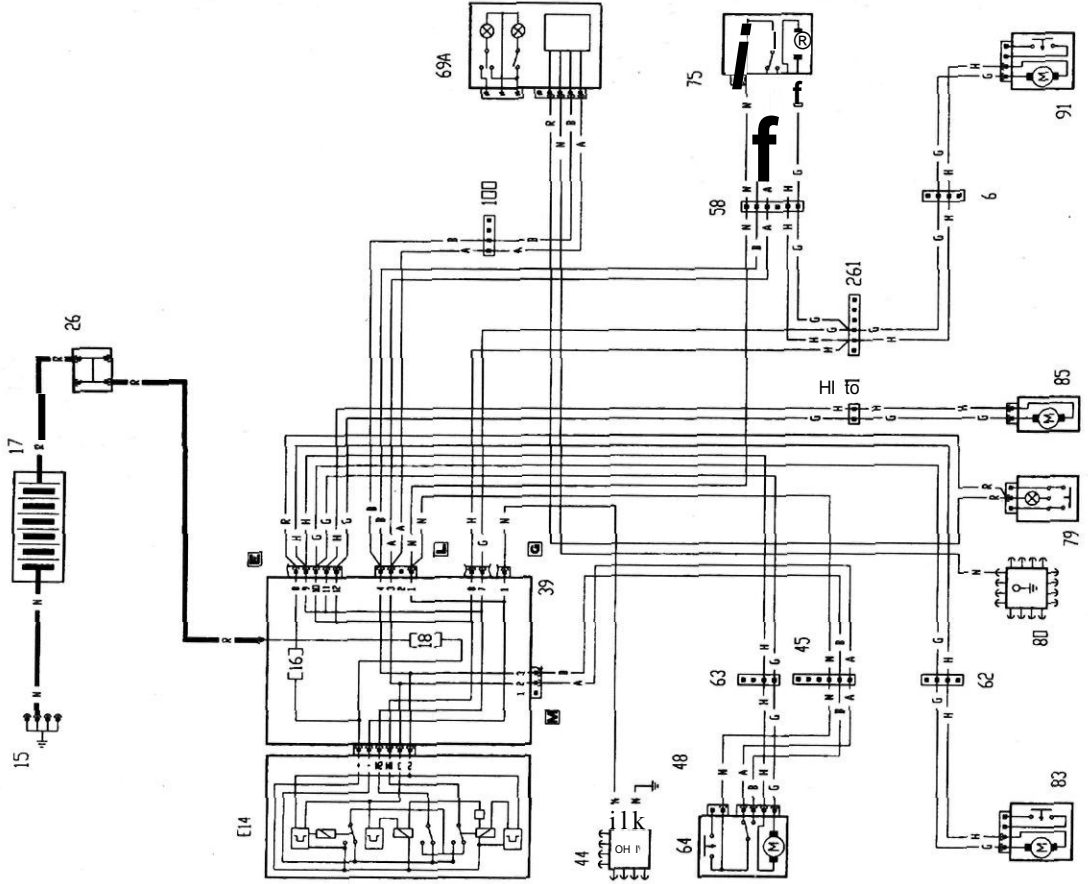

Diagram 30: Model: '93 Range - Super Specification 5 Doors - Electric Door Lock
 NB - 3 door models do not have items 83 and 91

- A**
Accelerator
 linkages and cables. 118, 119
Aerial 112
Airbag 14, 63, 128
Air cleaner/filter 51
Air Conditioning 12, 41
Alternator, drive belt 49, 50, 110
Antifreeze 43, 44
Anti-roll bars 131
Auto-Biography 1
Automatic transmission
 fluid. 45
 gear selector cable. 102
- B**
Ball-joints
 steering and suspension. 57
Battery
 disconnecting. 36
 electrolyte. 36
 safety. 7
Bellows, steering gear (see 'Gaiters')
Bonnet 15, 143
Brakes 59 to 62, 134 to 142
 bleeding. 141
 caliper. 59 to 61, 135, 137
 Cylinder (master). 138
 discs, front. 59, 135
 discs, rear. 61, 137
 drums. 60, 136
 fluid, check level. 35, 36
 handbrake. 61, 142
 hoses/pipes. 62, 141
 pads. 59, 135, 137
 pressure regulating/proportioning
 valve (ABS). 140
 pressure regulating/proportioning
 valve (Non-ABS). 139
 RPM sensors (ABS systems) 140
 safety 7
 servo. 138
 shoes. 135
 wear sensors (non-ABS). 60
Bulb renewal (see 'Lights')
Bushes 57
Bumper
 removal and refitting. 146
- C**
Cables
 accelerator. 118, 119
 automatic transmission 101, 102
 choke. 119
 Clutch. 46, 101
 handbrake. 61
Caliper, brakes (see 'Brakes')
Camshaft belt 43, 66
Capacities 19, 154
Carburettor
 adjustment 53
 removal. 117
Catalytic converter 54, 55
 safety. 6
Central locking 114
Choke 119
Clutch
 adjustment 46, 100
 hydraulic. 46, 105
 replacement. 100
 cable. 46, 101
Coil, ignition 47, 107, 108
Coil spring 57
Constant Velocity (C.V.) joints
 (see 'Driveshaft')
Contents 4
Controls and switches 10 to 14
Cooling system 35, 43, 106 to 107
 change coolant. 43
 radiator pressure cap. 35
 Crankcase ventilation system 4
 2
 Cylinder head
 Diesel. 87 to 93
- Petrol. 67 to 73
- D**
Data 17 to 27
Diesel
 bleeding the system. 126, 127
 fuel filter. 52
 glow plugs. 115
 injection pump. 56, 124
 injectors. 126
Disc, brakes (see 'Brakes')
Distributor 108, 109
 cap. 47
 Marelli Breakerless. 48
 Marelli Digiplex. 2, 48, 49
Doors
 hinges. 62
 locks and handles. 147 to 150
 removal and refitting. 147
 trim panels. 146
Drivebelts
 alternator. 49, 50, 110
 camshaft 43
Driveshaft
 C. V. joints. 103
 gaiters. 45, 103
 removal and refitting. 103
Drum (see 'Brakes')
- E**
Electrical system 110 to 115
Electronic control module 54
 safety. 7
Emergency starting 16
Emissions 31, 51 to 56
 control. 53, 54
 legal limits. 31
Engine bay layouts 34
Engine dismantling
 Diesel. 95
 Petrol. 73
Engine mountings
 Diesel. 95
 Petrol. 83
Engine oil (see 'Oil')
 check level. 34
Engine refitting
 Diesel. 94
 Petrol. 82
Exhaust manifold 56
Exhaust 56
 system. 56, 122
Expansion tank 35
- F**
Facts & Figures 17 to 27
Fan 50, 106
Fast idle
 carburettor. 53, 54
 fuel injection. 54
 diesel. 55
Filter
 air. 51
 diesel. 52
 petrol. 52
 oil (see 'Oil filter')
 pollen. 63
Fire Extinguisher 6
Fluoroelastomers, safety 8
Fuel cut-off switch 13
Fuel gauge 114
Fuel injection 52, 54, 55, 117
Fuel lines/pipes 51
Fuel pump
 electric. 120
 mechanical. 120
Fuel system 51 to 56
 evaporation control system 54, 122
Fuel tank 121
Fumes, safety 6
Fuses 40
- G**
Gaiters 30, 57
- Gearbox (transmission)** 44 to 46
 oil (automatic) 45
 oil (manual). 44
Generator drive belt (see 'Alternator, drive belt')
- H**
Handbrake 61, 142
Headlights (see 'Lights')
 adjustment 62
 bulb replacement. 37
Headrest 153
Heater 11
Hoses/pipes (see 'Pipes and hoses')
HT leads 47
Hub
 front. 104
 rear. 134
- I**
Identification numbers 27
Idle speed adjustment (see 'Carburettor')
Ignition system 46 to 51, 107 to 109
 coil. 47, 48
 safety. 7
Ignition timing 19, 48 to 50
Instruments 110
 panel lights. 10
Intercooler 123, 124
- J**
Jacking
 safety. 5
 wheelchange. 15, 16
Jump leads (Jump starting) 16
- L**
Lambda sensor 54, 55, 121, 122
Lights
 fog lights. 13, 38
 hazard warning. 13
 headlights. 13, 37
 indicators. 13, 37
 interior. 15, 39, 40
 MoT. 28
 number plate. 39
 rear lights. 38
 reversing lights. 39
 sidelights. 13, 37
Locks and latches 9, 10, 62
Lubricants 154
- M**
Manifold fixings 56
Mirrors 14, 150
Mixture adjustment (see 'Carburettor')
Model years 17, 18
MoT, getting through 28 to 31
- N**
Number plates (lights) 28, 39, 145
- O**
Oil change
 disposal. 7, 8
 engine. 41, 42
 transmission. 44, 45
 safety. 7
Oil filler cap 35
Oil filter 41
Oil level
 engine. 34, 35
 gearbox. 44, 45
 topping up. 35
- P**
Pads, brake (see 'Brakes')
Pipes and hoses
 brakes. 62, 138, 141
 hot air. 121
 radiator (cooling system). 43
Plastics, safety 7
Production changes 17, 18
- R**
Radiator 106
Raising the car 5
Repair data 20
Road test, brakes and steering 63
Rotor arm 47, 49
- S**
Safety First! 5 to 8
Seats 14, 151 to 153
 mountings. 62
Seat belts
 mountings. 62
 pretensioners. 151, 152
Servicing Your Car 32 to 63
Shock absorbers 57, 131
Shoes, brake (see 'Brakes')
Sidelights (see 'Lights')
Spark plugs 47, 154
Specifications (see 'Facts & Figures')
Speedometer cable 110
Starter motor 110
Steering 57, 58, 127 to 131
 lower wishbone. 127, 130
 power steering. 58, 130
 rack gaiters. 58, 133
Steering wheel 128
Sun roof 151
Suspension 57 to 59, 127 to 134
 front. 57, 127, 131
 rear. 58, 59, 128, 133
 strut 57, 131
- T**
Tailgate wiper (see 'Windscreen wipers')
Tailgate and strut 144
Thermostat 107
Throttle cable and pedal (see 'Accelerator, linkage and cables')
Timing belt 43
 Diesel. 85 to 87
 Petrol. 65, 66
Torque wrench settings 23 to 27
Track control arm (inner bushes) 57
Track rod ends 57, 58, 128
Transmission 80 to 83, 95, 98 to 106
 removal 80 to 82
 separation and reconnection (Diesel). 95
 separation and reconnection (Petrol). 83
Transmission fluid 44, 45
Turbocharger replacement 122 to 124
Tyre
 checking. 30, 36
 pressures. 18, 36
- U**
Universal joints 28, 58
Using your car 9 to 16
- V**
Vacuum unit, distributor 48
Valve clearances 42, 43, 79, 93
Valve grinding 72
Vehicle Identification Numbers (VIN) 27
- W**
Washer fluid reservoir 36
Water pump 107
Wheel alignment 28
Wheel bearings 57, 58
Wheel bolts 59
Wheel changing 15, 16
Wheel cylinder 137
Wheel sizes 18
Windscreen, damage 29, 162
Window regulator 147 to 149
Windscreen washers 112
Windscreen wipers 13, 111
Wiring diagrams 155 to 174

October 1991 2.0 i.e. 16v introduced, with 1995cc, 16valve high-performance DOHC engine, catalytic converter, sports suspension, front and rear disc brakes. ABS available as option.

January 1992 Existing Tipo models lightly facelifted and redesignated 1.4 Formula, 1.45, 1.6S, 1.6SX, 1.9TDSX, 1.8 i.e. SX. 1.7D discontinued. SX versions with digital instruments.

Tempra 7.9 TD5 (turbo diesel) Station Wagon introduced. 1.4 and 1.9D saloons discontinued.

May 1992 *Tempra* 1.8 i.e. SX Saloon and Station Wagon discontinued.

June 1992 *Tempra* 2.0 i.e. SX saloon and station wagon models introduced, with high performance 1995cc DOHC fuel injected engine, catalytic converter and disc brakes front and rear.

Tipo 1.4 and all *Tipo* and *Tempra* 1.6 models (except Selecta) now with a catalytic converter and fuel injection in place of Weber twin-choke carburettor. Designated i.e. in badging.

December 1992 *Tipo* 1.8 i.e. and 1.6 Selecta discontinued.

February 1993 *Tipo* 2.0 i.e. GT introduced. Slightly lower performance and spec, version of the 16v model.

July 1993 *Tipo* 1.4 now available as a 3-door or 5-door hatchback. 2.0 i.e. 16v now only available as 3-door. *Tipo* 2.0 i.e. GT replaced by similar spec. 2.0 i.e. SLX.

Tempra 2.0 i.e. SX saloons and estates now only available with auto, gearbox. Otherwise, SX models become known as SLX, with colour-coded mirrors and ABS brakes. Most *Tempras* now with body-coloured bumpers. 1.9D (non turbo Diesel re-introduced).

All *Tipo* and *Tempra* models now with revised front-end styling - narrower headlights and revised grille. Improved crash protection, including side impact beams, safety steering wheel and uprated brakes. Power steering, central locking, electric windows all standard.

February 1994 *Tipo* 1.7 non-turbo diesel re-introduced as 1.7DS.

May 1994 *Tempra* 1.9DS Station Wagon introduced.

September 1994 Most models available with driver's airbag, fire prevention system and seat belt pre-tensioners.

December 1994 *Tempra* 1.6 i.e. versions get M.P.I. engine.

February/March 1995 All models with VIN number window etching and immobiliser standard on all *Tempra* petrol models.

October 1995 Immobiliser fitted to *Tempra* D and TD models.

End of 1995 *Tipo* discontinued.

Mid-1996 *Tempra* discontinued.

PART B: VITAL STATISTICS

All *Tipo* models - 55 litres, except petrol with catalytic converter - 51 litres.

All *Tempra* models - 65 litres, except petrol with catalytic converter - 62 litres.

Wheels and Tyres

| ENGINE | PRESSED STEEL WHEEL RIM TYPE | RADIAL TUBELESS TYRE TYPE | TYRE PRESSURES (cold) | | | |
|--|---------------------------------|---------------------------------|-----------------------|----------------|----------------|----------------|
| | | | FRONT | | REAR | |
| | | | average load | heavy load | average load | heavy load |
| TIPO MODELS | | | | | | |
| 1.4 and 1.6 Petrol | 5.00Bx 13H | 165/70R13S | 2.0 bar/29 psi | 2.0 bar/29 psi | 1.9 bar/28 psi | 2.2 bar/32 psi |
| 1697 Diesel | 5.00Bx 13H | 165/70R 13S | 2.1 bar/30 psi | 2.1 bar/30 psi | 1.9 bar/28 psi | 2.2 bar/32 psi |
| Turbo D | 5.5Jx14H | 175/65R 14T | 2.2 bar/32 psi | 2.4 bar/35 psi | 2.2 bar/32 psi | 2.4 bar/35 psi |
| 1.4i.e./1.6Le.(1993-on) | 5.5J x 14H | 165/65R 14T | 2.0 bar/29 psi | 2.0 bar/29 psi | 1.9 bar/28 psi | 2.2 bar/32 psi |
| 1.7D(1993-on) | 5.5J x 14H | 165/65R 14T | 2.1 bar/30 psi | 2.1 bar/30 psi | 1.9 bar/28 psi | 2.2 bar/32 psi |
| Option - certain models | 5.5Jx14AH2 | 185/60R 14H | 2.2 bar/32 psi | 2.4 bar/35 psi | 2.2 bar/32 psi | 2.4 bar/35 psi |
| TEMPRA MODELS | | | | | | |
| Early 1.4 and 1.6 | | | | | | |
| Saloons | 5.00Bx13H | 165/70R 13S/T | 2.0 bar/29 psi | 2.0 bar/29 psi | 2.0 bar/29 psi | 2.2 bar/32 psi |
| 1.6 SX Saloon | 5.5Jx 14H | 165/65R 14T | 2.0 bar/29 psi | 2.0 bar/29 psi | 2.0 bar/29 psi | 2.2 bar/32 psi |
| 1.9D/1.9TD Saloon and Late 1.6 i.e. | 5.5Jx 14H | 175/65R 14T/H | 2.2 bar/32 psi | 2.4 bar/35 psi | 2.2 bar/32 psi | 2.4 bar/35 psi |
| 1.6/1.9D/1.9TD Station Wagons | 5.5JX 14H | 175/65R14H | 2.2 bar/32 psi | 2.4 bar/35 psi | 2.2 bar/32 psi | 3.0 bar/44 psi |
| Option for Station Wagons | 5.5Jx14HorAH2 (alloy) | 185/60R 14H | 2.2 bar/32 psi | 2.4 bar/35 psi | 2.2 bar/32 psi | 3.0 bar/44 psi |
| SPARE WHEEL - ALL TIPO AND TEMPRA MODELS (speed limit 50 mph) | | | | | | |
| Tempra TD Saloon and | | | | | | |
| ALL Station Wagons | 4.00B x 14H | 105/70 B14 | 4.2 bar/61 psi | | | |
| ALL other models | 4.00B x 14H | 135/80 B14 | 2.8 bar/41 psi | | | |

Weights and Dimensions. All weights in kg. All sizes in mm.

All figures are given for 1993 model-year. Other years may vary.

ALLTIPO AND TEMPRA MODELS: Maximum roof load - 80 kg (all models). Maximum weight on towball, when fitted - 75 kg.

| VEHICLE | UNLADEN WEIGHT | MAXIMUM LADEN WEIGHT | TOWABLE LIMITS WITHOUT BRAKES | TOWABLE LIMITS WITH BRAKES | OVERALL LENGTH | OVERALL WIDTH* * not including mirrors | WHEEL BASE | FRONT TRACK | REAR TRACK | HEIGHT (unladen) |
|------------------------|----------------|----------------------|----------------------------------|-------------------------------|----------------|---|------------|-------------|------------|---------------------------|
| TIPO MODELS | | | | | | | | | | |
| 1.4 | 1030 | 1530 | 400 | 1100 | | | | | | |
| 1.6 manual | 1050 | 1550 | 400 | 1100 | | | | | | |
| 1.6 auto. | 1080 | 1580 | 400 | 1100 | 3958 | 1700 | 2540 | 1436 | 1415 | 1445 |
| 1.9 Turbo D | 1160 | 1660 | 400 | 1200 | | | | | | |
| 1.7 Diesel | 1060 | 1560 | 400 | 1100 | | | | | | |
| TEMPRA MODELS | | | | | | | | | | |
| 1.4 Saloon | 1075 | 1575 | 400 | 1100 | | | | | | |
| 1.6 Saloon | 1080 | 1580 | 400 | 1200 | | | | | | |
| 1.6 Auto Saloon | 1120 | 1620 | 400 | 1100 | 4354 | 1695 | 2540 | 1425 | 1415 | 1445 |
| 1.9 D Saloon | 1170 | 1670 | 400 | 1200 | | | | | | |
| 1.9 TD Saloon | 1210 | 1710 | 450 | 1300 | | | | | | |
| 1.6 Station Wagon | 1140 | 1705 | 400 | 1200 | | | | | | |
| 1.6 Auto Station Wagon | 1180 | 1750 | 400 | 1100 | 4472 | 1695 | 2450 | 1425 | 1415 | 1500* |
| 1.9 D Station Wagon | 1230 | 1800 | 450 | 1300 | | | | | | (* roof bars - add 40 mm) |
| 1.9 TD Station Wagon | 1270 | 1840 | 450 | 1300 | | | | | | |

PART C: CAPACITIES

See RECOMMENDED FL LUBRICANTS on page 154.

PART D: SERVICE DATA

All setting in mm. unless stated otherwise.

Engine

FRING ORDER: All petrol models 1-3-4-2

INJECTION ORDER: All diesel models 1-3-4-2

IGNITION TIMING in degrees Before Top Dead Centre - BTDC:
850 rpm: 1372cc-8to 12 degrees. 1580/1581cc- 10 to 14 degrees.

SPARK PLUG TYPES AND GAPS

| Model | FIAT | Champion | Gap (mm) |
|--------------|--------|----------|------------|
| 1372cc | V4LSR | RN9YC | 0.7 to 0.8 |
| 1580/1581 cc | V45LSR | RN7YC | 0.7 to 0.8 |

IDLE SPEED:

Petrol: 800 to 850 rpm
Turbo Diesel: 880 to 920 rpm
Non-turbo Diesel: 740 to 780 rpm

.CO CONTENT AT IDLE (MAX): Petrol only - 0.5 to 1.5%

VALVE CLEARANCES (mm) Inlet Exhaust
(Checked when engine cold)

| | | |
|----------------|--------------|---------------|
| Petrol engines | 0.4 +/- 0.05 | 0.5 +/- 0.05 |
| Diesel engines | 0.3 +/- 0.05 | 0.35 +/- 0.05 |

Other settings

CLUTCH ADJUSTMENT: No pedal free-travel. Adjustable pedal height (see Chapter 5, Job 20).

BRAKE DISC PAD MINIMUM THICKNESS: Front (all models) and Rear (models with ABS) - Brake pad wear warning light on dash, but also check visually - minimum 1.5.

BRAKE SHOE FRICTION LINING MINIMUM THICKNESS: Rear (when applicable) - minimum 1.5.

TYRE PRESSURES: See page 18.

FIAT Tipo and Tempra

Repair Manual and Service Guide



by
Lindsay Porter
and **Roy Stenning**

Every care has been taken to ensure that the material in this book is correct. However, should any matter not be clear after reading this book, you are advised to consult your nearest franchised dealer. Liability cannot be accepted for damage, loss, accidents or injury, due to failure to follow instructions or to consult expert advice if this is required.

PART E: REPAIR DATA

Engine 'bottom end'

| | 1372 OHC | 1580/1581 OHC | 1697 Diesel | 1929 D | 1929 Turbo D (rdsX model shown separately, where different.) |
|---|--------------------------------------|--------------------------------------|--------------------------------------|--------------------------------------|---|
| BORE: | 80.5 | 86.4 | 82.6 | 82.6 | 82.6 |
| STROKE: | 67.4 | 67.4 | 79.2 | 90 | 90 |
| REBORE SIZE (steps of 0.01): | 80.5-80.55 | 86.4-86.45 | 82.6-82.65 | 82.6-82.65 | 82.6-82.65 |
| PISTON SIZES: | | | | | |
| Size A | 80.46-80.47 | 86.36-86.37 | 82.53-82.54 | 82.52-82.53 | 82.53-82.54 |
| Size C | 80.48-80.49 | 86.38-86.39 | 82.55-82.56 | 82.54-82.55 | 82.55-82.56 |
| Size E | 80.5-80.51 | 86.4-86.41 | 82.57-82.58 | 82.56-82.57 | 82.57-82.58 |
| PISTON PROJECTION AT TDC: | N/A | N/A | 0.667-1.132 | 0.367-0.832 | -0.032-0.432 |
| PISTON CLEARANCES IN BORE: | 0.03-0.05 | 0.03-0.05 | 0.06-0.08 | 0.07-0.09 | 0.06-0.08 |
| PISTON RING THICKNESS: | | -MHI | | | |
| TOP | 1.478-1.48 | 1.478-1.49 | 2.075-2.095 | 2.075-2.095 | 2.575-2.595 |
| SECOND | 1.728-1.74 | 1.728-1.75 | 1.975-1.99 | 1.978-1.99 | 1.978-1.99 |
| BOTTOM | 2.975-2.99 | 2.975-2.99 | 2.975-2.99 | 2.975-2.99 | 2.975-2.99 |
| PISTON RING CLEARANCES - RING-TO-GROOVE: | | | | | |
| TOP | 0.045-0.077 | 0.045-0.077 | 0.08-0.13 | 0.08-0.13 | 0.08-0.13 |
| SECOND | 0.04-0.072 | 0.04-0.072 | 0.03-0.05 | 0.02-0.052 | 0.02-0.052 |
| BOTTOM | 0.03-0.065 | 0.03-0.065 | 0.025-0.05 | 0.03-0.5 | 0.03-0.5 |
| PISTON RING END GAP: | J & 2: 0.3-0.5 3: 0.25-0.5 | 1 8.2:0.3-0.5 3:0.25-0.5 | 1 & 2; 0.3-0.5 3: 0.25-0.5 | 1 & 2: 0.3-0.5 3: 0.25-0.5 | 1:0.3-0.5 2 & 3: 0.2-0.4 |
| PISTON RING OVERSIZES: (All models) 0.2, 0.4, 0.6 | | | | | |
| CRANK MAIN JOURNAL DIAMETER: | 1: 50.79-50.8 2: 50.78-50.79 | 1: 50.79-50.8 2: 50.78-50.79 | 1: 52.995-53.004 2: 52.986-52.995 | 1: 52.995-53.004 2: 52.986-52.995 | 1: 52.995-53.004 2: 52.986-52.995 |
| CRANK, BIG-END DIAMETER: | A: 45.513-45.523 B: 45.503-45.513 | A: 45.513-45.523 B: 45.503-45.513 | A: 50.796-50.805 B: 50.787-50.796 | 1: 50.796-50.805 2: 50.787-50.796 | A: 50.796-50.805 B: 50.787-50.796 |
| MAIN BEARING SHELL THICKNESS: | 1: 1.84-1.844 2: 1.845-1.849 | 1: 1.84-1.844 2: 1.845-1.849 | 1: 1.839-1.843 2: 1.843-1.847 | 1: 1.839-1.843 2: 1.843-1.847 | 1: 1.837-1.843 2: 1.843-1.849 |
| MAIN BEARING CLEARANCES: | 0.019-0.05 | 0.019-0.05 | 0.027-0.062 | 0.027-0.062 | 1:0.027-0.066 2: 0.024-0.963 |
| MAIN BEARING UNDERSIZES: | A: 0.254 B: 0.508 | A: 0.254 B: 0.508 | A: 0.254 B: 0.508 | A: 0.254 B: 0.508 | A: 0.254 B: 0.508 |
| BIG-END BEARING SHELL THICKNESS (STANDARD): | A: 1.535-1.541 B: 1.54-1.546 | A: 1.535-1.541 B: 1.54-1.546 | A: 1.528-1.532 B: 1.533-1.537 | A: 1.528-1.532 B: 1.533-1.537 | A: 1.527-1.533 B: 1.533-1.539 |
| BIG-END BEARING CLEARANCE: | 0.025-0.063 | 0.025-0.063 | 0.028-0.061 | 0.028-0.061 | A: 0.026-0.063 B: 0.023-0.060 |
| BIG-END BEARING UNDERSIZES: | A: 0.254 B: 0.508 | A: 0.254 B: 0.508 | A: 0.254 B: 0.508 | A: 0.254 B: 0.508 | A: 0.254 B: 0.508 |
| THRUST WASHER THICKNESS: | 2.31-2.36 | 2.31-2.36 | 2.31-2.36 | 2.31-2.36 | 2.31-2.36 |
| THRUST WASHER OVERSIZE: | 0.127 | 0.127 | 0.127 | 0.127 | 0.127 0.127 |

1372 OHC 1580/1581 OHC 1697 Diesel 1929 D 1929 Turbo D

CRANKSHAFT END FLOAT:

0.055-0.265 0.055-0.265 0.055-0.305 0.055-0.305 0.055-0.305

Engine 'top end' and valve gear

CAMSHAFT BEARING OUTER DIAMETERS (1 = Front)

| | | | | | |
|----|---------------|---------------|--------------|--------------|--------------|
| 1: | 29.989-30.014 | 29.989-30.014 | 42.02-43.04 | 43.02-43.04 | 43.02-43.04 |
| 2: | 47.98-48.005 | 47.98-48.005 | 25.545-25.57 | 25.545-25.57 | 25.545-25.57 |
| 3: | 48.180-48.205 | 48.180-48.205 | 24.045-24.07 | 24.045-24.07 | 24.045-24.07 |
| 4: | C48.38-4S.405 | 48.38-48.405 | 43.02-43.04 | 43.02-43.04 | 43.02-43.04 |
| 5: | A48.58-48.605 | 48.58-48.605 | N/A | N/A | N/A |

CAM FOLLOWER DIAMETER:

36.975-36.995 36.975-36.995 36.975-36.995 36.975-36.995 36.975-36.995

CAM FOLLOWER BORE CLEARANCE:

0.005-0.05 0.005-0.05 0.005-0.05 0.005-0.05 0.005-0.5

INLET VALVE HEAD SIZE:

37.35-37.65 A: 37.35-37.65
B: 39.2-39.7 37.3-37.6 37.3-37.6 37.3-37.6

EXHAUST VALVE HEAD SIZE:

30.85-31.15 A: 32.85-33.45
B: 30.85-31.15 33.3-33.6 33.3-33.6 33.3-33.6

VALVE SEAT RE-CUTTING ANGLE:

45 degrees, +/-5' 45 degrees, +/-5' 45 degrees, +/-5' 45 degrees, +/-5' 45 degrees, +/-5'

VALVE FACE RE-CUTTING ANGLE:

45 degrees 30' +/-5' 45 degrees 30' +/-5' 45 degrees 30' +/-7' 45 degrees 30' +/-1' 45 degrees 30' +/-7'

VALVE SHIM THICKNESSES: Between 3.25 and 4.7 mm in shim increments of 0.05 mm

| | | | | |
|-----------------|-----------------|-----|-----|-----|
| 1:35.593-35.618 | 1:35.593-35.618 | N/A | N/A | Hit |
| 2:31.940-39.960 | 2:31.940-39.960 | | | |

PRECHAMBER PROTRUSION BEYOND CYLINDER HEAD (arrowed):

N/A N/A -0.765-0.055 -0.765-0.055 -0.765-0.055

Cooling system

All figures in degrees Celsius unless stated otherwise.

THERMOSTAT: (starts opening)

85-89 85-89 80-82 80-82 80-82

THERMOSTAT: (fully open)

96-100 96-100 90 90 90

THERMOSTAT VALVE TRAVEL, at least:

7.5 mm 7.5 mm 7.5 mm 7.5 mm 7.5 mm

PRESSURE CAP RATING: All models: 0.98 bar (14 lbf/sq.in.) - except Turbo Diesel models: 0.78 bar (11 lbf/sq.in.)

COOLING FAN - Switches on:

| | | | | |
|-------|-------|-------|----------------------------|----------------------------|
| 90-94 | 90-94 | 86-90 | SLOW: 86-90 FAST: 90-94 | SLOW: 86-90 FAST: 90-94 |
|-------|-------|-------|----------------------------|----------------------------|

COOLING FAN - Switches off:

| | | | | |
|-------|-------|-------|----------------------------|----------------------------|
| 85-89 | 85-89 | 81-85 | SLOW: 81-85 FAST: 85-89 | SLOW: 81-85 FAST: 85-89 |
|-------|-------|-------|----------------------------|----------------------------|

WATER TIGHTNESS PRESSURE CHECK:

0.98 bar 0.98 bar 0.78 bar 0.78 bar 0.78 bar

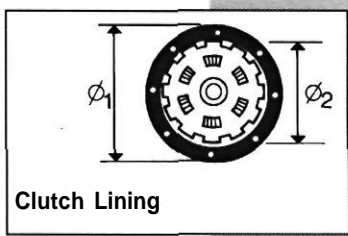
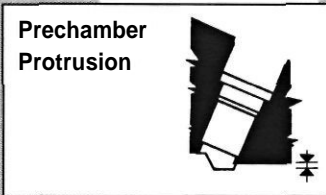

Clutch

LINING, OUTER DIAMETER (1), mm:

180 190 200 215 215

LINING, INNER DIAMETER (2), mm:

125 134 137 145 145

Brakes

GAP - SERVO PISTON PUSHROD FROM SUPPORT PLATE (d):

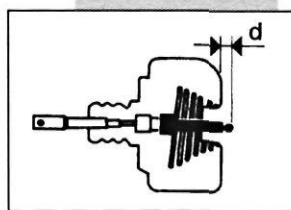

| | | | | | |
|--|--------------------|--------------------|--------------------|-------------|--------------|
| | 22.45-22.65 | 22.45-22.65 | 22.45-22.65 | 22.45-22.65 | 22.45-22.65 |
| MINIMUM ALLOWED FRONT DISC THICKNESS (mm): | | | | | |
| NON-ABS: 9.2 | NON-ABS: 9.2 | NON-ABS: 9.2 | NON-ABS: 9.2 | 10.2 | 10.2 |
| ABS: 10.2 | ABS: 10.2 | ABS: 10.2 | | | (TdsX: 10.8) |
| MINIMUM ALLOWED REAR DISC THICKNESS - when applicable - (mm): | | | | | |
| 9.2 | 9.2 | 9.2 | | ABS: 9.2 | ABS: 9.2 |
| MINIMUM ALLOWED BRAKE DRUM INTERNAL DIAMETER - when applicable - (mm): | | | | | |
| 181.35 | A: 181.35 B:230 | A: 181.35 B:230 | A: 181.35 B:230 | 230 | 230 |

Running gear/suspension - front

| | | | | | |
|---|-------------------------|--------------------------|-------------------------|--|--|
| CAMBER (not adjustable): | -20'to40' | -20'to40' | -20'to40' | -20'to40' | -20to40' (TdsX: 25'+/-30') |
| FRONT CASTER (not adjustable): | 1 degree50'-2degrees50' | 1 degree50'-2 degrees50' | 1 degree50'-2degrees50' | 1 degree 50'-2degrees 50' | 1 degree50'-2degrees50' (TdsX: 2 degrees 50') |
| TOE-IN (adjustable) | $\frac{m}{f}$ | $\frac{m}{f}$ | $\frac{m}{f}$ | $\frac{m}{f}$ | $\frac{m}{f}$ |
| FRONT SPRING HEIGHT RELEASED (mm): | 432 | EARLY: 432 LATE: 444 | 461 | EARLY: 489 LATE: 472 TEMPRA: 489 | EARLY: 489 LATE: 472 TEMPRA: 493 |
| FRONT SPRING: when the given toad in Nm is applied, the spring height should equal 191 mm: | 3020-3330 | 3020-3330 | 3310-3590 | 3600-3900 | 3600-3900 |
| REPLACEMENT FRONT SPRING COLOURS: If new springs fail to give the above heights, YELLOW SPRINGS give LOWER heights; GREEN springs give HIGHER. ALWAYS use them in pairs of same colour. | | | | | |

Rear suspension

| | | | | | |
|--|----------------------|-----------------------|-----------------------|-----------------------|--|
| CAMBER (not adjustable): | A degree 30' to -30' | -1 degree 30' to -30' | -1 degree 30' to -30' | -1 degree 30' to -30' | -1 degree 30' to -30' (TdsX: 1 degree 30' +M\$) |
| TOE-IN (not adjustable): | $\frac{m}{f}$ | $\frac{m}{f}$ | $\frac{m}{f}$ | $\frac{m}{f}$ | $\frac{m}{f}$ |
| REAR COIL SPRING HEIGHT, RELEASED (mm): | 3270 | 3270 | 3270 | 3270 | 3270 |
| TEMPRA: 3390 | TEMPRA: 3390 | TEMPRA: 3390 | TEMPRA: 3390 | TEMPRA: 3390 | TEMPRA: 3390 |
| REAR COIL SPRING HEIGHT, LOAD in NM REQUIRED TO COMPRESS TO 195 mm. | 2930-3170 | 2930-3170 | 2930-3170 | 2930-3170 | 2930-3170 |
| TEMPRA: 3120-3380 | TEMPRA: 3120-3380 | TEMPRA: 3120-3380 | TEMPRA: 3120-3380 | TEMPRA: 3120-3380 | TEMPRA: 3120-3380 |
| REPLACEMENT REAR SPRING COLOURS: if new springs fail to give the above heights, YELLOW springs give LOWER heights; GREEN springs give HIGHER. ALWAYS use them in pairs of same colour. | | | | | |

(*) The bolt need not be greased

PART F: TORQUE WRENCH SETTINGS

**Key for engine types and sizes: A - 1372cc; B - 1581cc;
C - 1697« Diesel; D - 1929cc Diesel; E - 1929cc Turbo Diesel.**

IMPORTANT NOTE: AM torque settings shown in Newton-meters (Nm). Bolt, nut or screw sizes in brackets in left-hand column.

Engine

| |
|---|
| Screw retaining caps to crankcase (M10x 1.25)..... |
| Screw retaining intermediate and central caps to crankcase (M12 x 1.25)..... |
| Self-locking screw retaining front and rear caps to crankcase (M12 x 1.25)..... |
| Bolt, cylinder head to engine block (M10 x 1.25)..... |
| |
| Bolt, cylinder head to engine block (M12 x 1.25) |
| |
| Bolts, top to bottom cylinder head (M8)..... |
| Nut for connecting rod cap retaining bolt (M9 x 1)..... |
| Screw, connecting rod cap (M10 x 1)..... |
| Screw retaining engine vent to crankcase (M8)..... |
| (M8)..... |
| Screw retaining front cover to crankcase (M10x1.25)..... |
| (M8)..... |
| Bolt retaining rear cover (flywheel side) to crankcase (M6)..... |
| Nut retaining inlet and exhaust ducts to cylinder head (M8)..... |
| (M8)..... |
| Screw, flywheel to crankshaft (M10x 1.25)..... |
| (M12x 1.25)..... |
| Lower belt cover retaining screw (M8)..... |
| Screw, damping flywheel to drive gear (M8)..... |
| Nut retaining auxiliary drive pulley to crankshaft (M20 x 1.25)..... |
| Screw retaining drive shaft to crankshaft (*) (M14x 1.5 left)..... |
| Screw, timing gears (M10x1.25)..... |
| (M12x1.25)..... |
| Belt tensioner retaining bolt (M8)..... |
| (M10x1.25)..... |
| Fixed belt tensioner retaining screw (M10 x 1.25)..... |
| Screw retaining auxiliary component driven gear (oil pump) (M10 x 1.25)..... |
| Nut for camshaft cap retaining stud (M8)..... |
| Nut retaining camshaft and air vacuum pump end mounts (M8)..... |
| Combustion prechamber retaining ring (M32 x 1.5)..... |
| Nut, injection pump stud (M8)..... |
| Screw, injection pump (M8)..... |
| Nut fastening flexible block to coolant pump case (M12 x 1.25)..... |
| Nut, injection pump gear (M12 x 1.75)..... |
| Screw retaining reaction bracket to oil filter support and injection pump (M8)..... |
| Top retaining screw or nut, oil filter support and injection pump (M12 x 1.25)..... |
| Lower retaining screw, oil filter support and injection pump (M10 x 1.25)..... |
| Complete injector (M24 x 2)..... |
| Glow plugs (M12x 1.25)..... |
| Nuts retaining fuel delivery line to injection pump and injector (M12 x 1.25)..... |
| Bolt, coolant pump to engine block (M8 x 1)..... |
| Bolt retaining cover and bracket to coolant pump case (M8)..... |
| Oil pressure switch (M14x 1.5)..... |
| Coolant temperature sender unit (M16x 1.5 tapered)..... |
| (M18x 1.5 tapered)..... |
| Coolant temperature thermal switch (M16 x 1.5 tapered)..... |

| A | B | C | D | E | Torque (Nm) |
|---|---|------|------|---|------------------------------|
| • | • | | | | 80 |
| | | • | • | • | 113 |
| | | • | • | • | 113 |
| ● | # | | | | 40 + 90 degrees + 90 degrees |
| | | * | ● | ● | 100+ 90 degrees + 90 degrees |
| • | • | | | | 28 |
| • | • | | | | 51 |
| | | • | • | • | 25 + 50 degrees |
| • | • | ● | ● | ● | 25 |
| | | ● | ● | ● | 20 |
| | ● | | | | 50 |
| | ● | | | | 25 |
| | • | | | | 10 |
| • | • | ● | ● | ● | 28 |
| | | ● | ● | ● | 25 |
| • | • | ● | ● | ● | 83 |
| | | ● | ● | ● | 142 |
| # | • | | | | 25 |
| | | • | • | • | 28 |
| ● | • | | | | 155 |
| | | • | • | • | 190 |
| • | • | ● | ● | ● | 83 |
| | | ● | ● | ● | 118 |
| • | • | | | | 25 |
| | | ⊖ | ⊖ | ● | 44 |
| | | ⊖ | ⊖ | ● | 44 |
| ● | • | | | | 83 |
| | | ⊖ | ⊖ | ● | 19 |
| | | ⊖ | ⊖ | ● | 19 |
| | | ⊖ | ⊖ | ● | 118 |
| | | ⊖ | ⊖ | ● | 25 |
| | | ● | ⊖ | ● | 25 |
| | | ⊖ | ⊖ | | 80 |
| | | i) ⊖ | ⊖ | ● | 49 |
| | | i) ⊖ | i) ⊖ | • | 29 |
| | | i) ⊖ | i) ⊖ | • | 98 |
| | | i) ⊖ | i) ⊖ | • | 71 |
| | | i) ⊖ | i) ⊖ | ● | 55 |
| | | i) ⊖ | i) ⊖ | ● | 15 |
| | | ⊖ | i) ⊖ | ● | 29 |
| | | i) ⊖ | i) ⊖ | ● | 25 |
| | | i) ⊖ | i) ⊖ | * | 23 |
| ● | ● | ● | ● | ● | 32 |
| | | • | • | • | 34 |
| ● | ● | | | | 30 |
| • | • | | | | 30 |

(*) The bolt need not be greased.

| | A | B | C | D | E | Torque (Nm) |
|--|---|---|---|---|---|-------------|
| Thermal valve on inlet manifold <M10x 1.25 tapered)..... | • | • | | | | 20 |
| (M8x 1.25 tapered)..... | • | • | | | | 9.5 |
| Oil pressure sending unit (M14x 1.5)..... | | | • | • | • | 30 |
| Oil temperature sender unit (M14 x 1.5 tapered)..... | | | | | • | 37 |
| Oil level sending unit (M12 x 1.25)..... | | | | | • | 25 |
| Engine oil sump retaining bolt/nut (M6)..... | • | • | | | | 10 |
| Screw retaining oil sealing cover to crankcase (M6)..... | • | • | | | | 10 |
| Nut retaining manifold support bracket (M8)..... | | | | | • | 34 |
| Nut retaining turbine to exhaust manifold (M8)..... | | | | | • | 40 |
| Air pressure switch on inlet manifold (M12 x 1.5)..... | | | | | • | 30 |

Power Unit Mounting

ENGINE SIDE

| | A | B | C | D | E | Torque (Nm) |
|---|---|---|---|---|---|-------------|
| Screw (with long flange) retaining flexible block to rail (M8)..... | • | • | • | • | • | 40 |
| Self-locking nut with plastic ring (for through screw) retaining flexible block to engine bracket (M10 x 1.25)..... | • | • | | | | 49 |
| Screw retaining flexible block supporting bracket to crankcase (M10. 1.25)..... | • | • | | | | 70 |
| (M12x 1.25)..... | | • | | | • | 88 |
| Bolt retaining flexible block to engine bracket (M12 x 1.25)..... | | • | • | | • | 88 |
| Bolt retaining power unit suspension link (M10 x 1.25)..... | • | • | • | • | • | 50 |

GEARBOX SIDE

| | | | | | | |
|--|---|---|---|---|---|----|
| Screw (with wide flange) retaining flexible block to rail (M8)..... | • | • | • | • | • | 40 |
| Flanged screws retaining support to plate on gearbox (M10 x 1.25)..... | • | • | • | • | • | 49 |
| Self-locking nut with plastic ring (for through screw) retaining flexible block to gearbox side bracket (M10x 1.25)..... | • | • | | | | 49 |
| Flanged screw retaining flexible block to gearbox side bracket (M12 x 1.25)..... | | • | • | | • | 88 |

DIFFERENTIAL SIDE

| | | | | | | |
|---|---|---|---|---|---|----|
| Screw with flange unit retaining elastic block to beam (M8)..... | • | • | • | • | • | 38 |
| Self-locking nut retaining bracket to gearbox support (M8)..... | • | • | • | | | 24 |
| (M12x1.25)..... | • | • | • | • | • | 88 |
| Screw retaining bracket brace to support on gear case (M10 x 1.25)..... | • | • | • | • | • | 49 |
| Screw, rubber block to bracket <M 12 x 1.25)..... | • | • | • | • | • | 88 |

Exhaust

| | A | B | C | D | E | Torque (Nm) |
|--|---|---|---|---|---|-------------|
| Nut retaining flange to exhaust manifold (M8)..... | • | • | | | | 25 |
| Nuts for bolts fastening collars joining exhaust pipe sections (M10 x 1.25)..... | • | • | • | • | • | 49 |
| Bolt retaining exhaust pipe sleeve to turbine (M8)..... | | | | | • | 16 |
| Bolt retaining front exhaust pipe section to gearbox (M8)..... | | | | | • | 16 |
| Metex joint to nut and stud manifold to plate and spring retainer (M8)..... | | | • | • | | 18 |
| Nut for bolt anchoring first exhaust pipe section (M8)..... | | | • | • | | 6 |
| Nut retaining bracket anchoring first exhaust pipe section (M12 x 1.25)..... | | | • | • | | 88 |
| Screw with normal flange retaining exhaust pipe terminal block support bracket (M8)..... | • | • | • | • | • | 18 |

Fuel Circuit

| | A | B | C | D | E | Torque (Nm) |
|--|---|---|---|---|---|-------------|
| Bolt (with wide flange) retaining tank and fitting to body (M8)..... | • | • | • | • | • | 28 |
| Ring retaining delivery, recirculation and vent fitting mounts to tank (131 x6 -Trapezoid thread)..... | • | • | • | • | • | 60 |
| Screw (with wide flange) retaining fuel filter support bracket (M8)..... | • | • | • | • | • | 28 |

Lubrication and Cooling Circuit

| | A | B | C | D | E | Torque (Nm) |
|--|---|---|---|---|---|-------------|
| Self-locking nut for screw fastening radiator support bracket to body (M6) | ● | ● | ● | ● | ● | 4.4 |
| Flanged screw, radiator support beam to body (M8)..... | ● | ● | ● | ● | ● | 28 |
| Flanged screw retaining heater (M6)..... | ● | ● | ● | ● | ● | 9 |

Clutch

| | A | B | C | D | E | Torque (Nm) |
|---|---|---|---|---|---|-------------|
| Screw with split safety washer retaining clutch mechanism (M8)..... | | • | • | | • | 38 |
| (M6)..... | • | | | | | 16 |

Gearbox Differential

| | A | B | C | D | E | Torque (Nm) |
|---|---|---|---|---|---|-------------|
| Tapered threaded plug for filling gear case with oil (M22 x 1.5)..... | ● | ● | ● | ● | ● | 46 |

External Gearbox Control

| | A | B | C | D | E | Torque (Nm) |
|--|---|---|---|---|---|-------------|
| Oil pressure switch (M10x 1.25 tapered)..... | | • | | | | 18 |

Braking System

| | A | B | C | D | E | Torque (Nm) |
|--|---|---|---|---|---|-------------|
| 30t retaining brake carrier plate to rear suspension arm (rear drum brakes) (M8)..... | • | • | • | • | • | 24 |
| Bolt retaining caliper support to rear top arm (rear disc plate) (M8)..... | | • | | | • | 24 |
| Bolt retaining rear brake caliper to plate (rear disc plates) (M10 x 1.25)..... | | • | | | • | 53 |
| Screw retaining front brake caliper to pillar (M10 x 1.25)..... | ● | ● | ● | ● | ● | 53 |
| Bolt retaining front brake disc and rear brake drum or disc to hub (M8)..... | ● | ● | ● | ● | ● | 12 |
| Fitting connecting hose to front brake caliper (M10 x 1)..... | ● | ● | ● | ● | ● | 18 |
| Bleed screw on front brake caliper (M8)..... | ● | ● | ● | ● | ● | 5.7 |
| Fitting connecting hose to rear brake caliper (rear disc plates) (M10 x 1)..... | | • | | | • | 16 |
| Bleed screw on rear brake caliper (rear disc plates) <M7)..... | | • | | | • | 5.7 |
| Bolt with split safety washer retaining brake system bracket assembly (M8)..... | ● | ● | ● | ● | ● | 25 |
| Bolt retaining cylinder to rear drum brake carrier plate (M6)..... | ● | ● | ● | ● | ● | 10 |
| Bleed screw on rear drum brake cylinder (M8)..... | ● | ● | ● | ● | ● | 11 |
| Male fitting for hoses with flared ends fastening rigid pipe to front and rear hoses (M10 x 1)..... | • | • | • | • | • | 14 |
| Male fitting for hoses with flared ends fastening rigid pipe to hose on rear axle (M10 x 1)..... | • | • | • | • | • | 14 |
| Bolt retaining brake fluid reservoir to body (M8)..... | • | • | | | | 9 |
| Nut retaining brake fluid reservoir to body (M6)..... | | | | | • | 3.9 |
| Bolt retaining brake fluid reservoir to body (M6)..... | | • | | | • | 3.9 |
| Male fitting for flared hoses fastening rigid pipe to rear drum brake cylinder (M10 x 1)..... | • | • | • | • | • | 14 |
| Male fitting for flared hoses fitting brake pipe to pump and cast iron Ip valve (M10x1)..... | • | • | • | • | • | 14 |
| (M12x 1)..... | • | • | • | • | • | 14 |
| Male fitting for flared hoses fitting brake pipe to 4-way control valve and aluminium load prop, valve (M10x 1)..... | • | • | • | • | • | 14 |
| (M12x1)..... | • | • | « | • | • | 14 |

Load Proportioning Valve Fasteners

| | A | B | C | D | E | Torque (Nm) |
|--|---|---|---|---|---|-------------|
| Bolt retaining load proportioning valve to bracket (M6)..... | ● | ● | ● | ● | ● | 7.6 |
| Self-locking nut for bolt retaining valve spring bracket to rear anti-roll bar (M6)..... | ● | ● | ● | ● | ● | 4.4 |
| Bolt retaining square lever for load proportioning valve adjustment (M8)..... | ● | ● | ● | ● | ● | 18 |
| Bolt retaining load prop, valve to rail (for Girling ABS) (M8)..... | | • | | | • | 15 |
| Bolt retaining square lever for load prop, valve adjustment (M6)..... | | • | | | • | 8 |

Handbrake Control

| | A | B | C | D | E | Torque (Nm) |
|--|---|---|---|---|---|-------------|
| Screw with broad flange retaining handbrake and gear lever to body (M8)..... | ● | ● | ● | ● | ● | 28 |
| Bolt retaining handbrake and gearlever to body (M8)..... | ● | ● | ● | ● | ● | 15 |
| Screw with normal flange retaining handbrake lever bracket to plate (M8)..... | ● | ● | ● | ● | ● | 28 |
| Screw with normal flange retaining handbrake cable slide plate to floorpan (M6)..... | ● | ● | ● | ● | ● | 8.5 |
| Screw with long flange for fastening handbrake cable reaction bracket to floor (M8)..... | • | • | • | • | • | 35 |
| Screw with broad flange retaining pedal unit to dashboard (M8)..... | ● | ● | ● | ● | ● | 32 |
| Self-locking nut for bolt retaining brake servo to pedal unit (M8)..... | ● | ● | ● | ● | ● | 15 |
| Nut for through screw joining brake and clutch pedals to pedal unit (M8)..... | ● | ● | ● | ● | ● | 32 |
| Self-locking nut retaining accelerator pedal to pedal unit (M6)..... | ● | ● | ● | ● | ● | 4.4 |
| Nut retaining brake pump to brake servo (M8)..... | ● | ● | ● | ● | ● | 20 |

Steering

| | A | B | C | D | E | Torque (Nm) |
|--|---|---|---|---|---|-------------|
| Self-locking nut retaining steering link ball pin to cast iron pillar (M1 Ox 1.25)... | ● | ● | ● | ● | ● | 34 |
| Bolt retaining steering and/or power steering box to front beam (M10 x 1.25)... | ● | ● | ● | ● | ● | 70 |
| Nut for side steering link (M12 x 1.25)..... | ● | ● | ● | ● | ● | 34 |
| Self-locking nut retaining steering shaft universal joint forks (M8)..... | ● | ● | ● | ● | ● | 20 |
| Self-locking nut retaining steering wheel to column (M16 x 1.5)..... | ● | ● | ● | ● | ● | 50 |
| Bolt retaining steering column mount to body (M6)..... | ● | ● | ● | ● | ● | 7.4 |
| Self-locking nut for steering wheel position adjustment device (tighten nut to specified torque with lever in locked position) (M12 x 1.25)..... | ● | ● | ● | ● | ● | 24 |
| Nut for screw retaining steering column to support (M8)..... | ● | ● | ● | ● | ● | 24 |
| Self-locking nut with polyamide ring retaining damper to steering box(M8)..... | ● | ● | ● | ● | ● | 15 |
| Union for oil delivery fitting from pump to power steering, on power steering (M14 x 1.5)..... | ● | ● | ● | ● | ● | 30 |
| Union for adjustable oil delivery fitting from pump to p.s., on power steering (M16 x 1.5)..... | ● | ● | ● | ● | ● | 35 |
| Union for oil delivery fitting from power steering to reservoir (M12 x 1.5)..... | ● | ● | ● | ● | ● | 20 |
| Union oil return fitting from reservoir to pump (M18 x 1.5)..... | ● | ● | ● | ● | ● | 34 |

Front Suspension

| | A | B | C | D | E | Torque (Nm) |
|---|---|---|---|---|---|-------------|
| Screw with broad flange retaining front of front beam to body (M12x 1.25)..... | • | • | • | • | • | 108 |
| Screw with normal flange for nut retaining rear of front beam to body (M10x 1.25)..... | • | • | • | • | • | 80 |
| Screw with flat and tapered washer for nut retaining front and rear ext. of wishbone connection plates to beam (M10x 1.25)..... | ● | ● | ● | ● | ● | 69 |
| Screws with flat and tapered washer for nut retaining front and rear inner swinging arm connection plates to beam (M10 x 1.25)..... | ● | ● | ● | ● | ● | 69 |
| Flanged nut fastening top of damper to block (M12 x 1.25)..... | ● | ● | ● | ● | ● | 100 |
| Screw with broad flange retaining top damper block to body (M8)..... | ● | ● | ● | ● | ● | 40 |
| Self-locking nut retaining damper to pillar (M10 x 1.25)..... | ● | ● | ● | ● | ● | 70 |
| Self-locking nut for screw retaining wishbone head and joint to pillar (M10x 1.25)..... | • | • | • | • | • | 70 |
| Screw with tapered and flat safety washer retaining stabilizer bar support plate to beam (M8)..... | • | • | • | • | • | 40 |
| Self-locking nut retaining end of anti-roll bar to rod (M10 x 1.25)..... | ● | ● | ● | ● | ● | 70 |
| Self-locking nut retaining bar to front suspension arm (M10 x 1.25)..... | ● | ● | ● | ● | ● | 31 |
| Nut retaining front wheel hub to coupling (M22x1.5i)..... | • | • | • | • | • | 24 |
| (M24x1.5)..... | • | • | • | • | • | 28 |
| Wheel stud (M12 x 1.25)..... | • | • | • | • | • | 86 |

Rear Suspension

| | A | B | C | D | E | Torque (Nm) |
|--|---|---|---|---|---|-------------|
| Screw with broad flange retaining front flexible block to rear subframe (M12x 1.25)..... | • | • | • | • | • | 108 |

- Screw with broad flange retaining rear flexible block to body (M12 x 1.25).....
- Nut for stud retaining rear swinging arm to subframe (M16x 1.5).....
- Nut for screw retaining lower damper to suspension (M12 x 1.25).....
- Screw retaining top of damper to mount (M10 x 1.25).....
- Nut for pivot pin retaining rear hub (M22 x 1.5).....
- Bolt retaining stabilizer bar to rear suspension arm (M10 x 1.25).....
- Bolt retaining stabilizer bar support plate to rear suspension arm (M8).....
- Wheel stud (M12x 1.25).....
- Nut with self-locking flange retaining headlight alignment corrector receiver to rear suspension (M8).....
- Nut with self-locking flange retaining lower receiver rod pin (M6).....
- Bolt with normal notched flange retaining automatic headlight alignment device mount (M8).....
- Bolt with normal notched flange retaining receiver connection bracket with rear suspension wishbone (M6).....
- Nut for bolt retaining square lever to wishbone (M8).....

| | A | B | C | D | E | Torque (Nm) |
|---|---|---|---|---|---|-------------|
| ● | ● | ● | ● | ● | ● | 108 |
| ● | ● | ● | ● | ● | ● | 150 |
| ● | ● | ● | ● | ● | ● | 88 |
| ● | ● | ● | ● | ● | ● | 60 |
| ● | ● | ● | ● | ● | ● | 280 |
| ● | ● | ● | ● | ● | ● | 56 |
| ● | ● | ● | ● | ● | ● | 28 |
| ● | ● | ● | ● | ● | ● | 86 |
| ● | ● | ● | ● | ● | ● | 6.4 |
| ● | ● | ● | ● | ● | ● | 3.9 |
| ● | ● | ● | ● | ● | ● | 12 |
| ● | ● | ● | ● | ● | ● | 3.9 |
| ● | ● | ● | ● | ● | ● | 15 |

PART G: IDENTIFICATION NUMBERS

Finding the Numbers

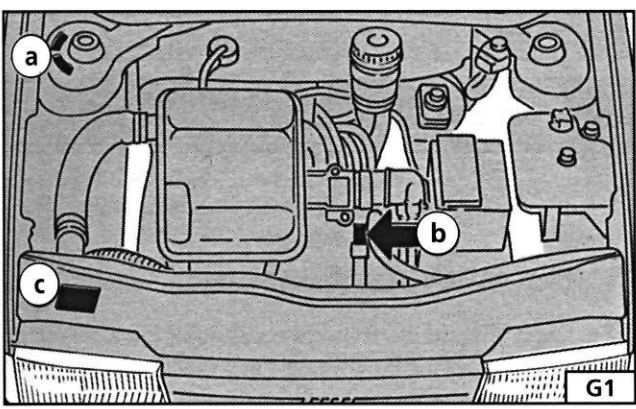

G1: There are four sets of identification numbers in all. First, there is the Vehicle Identification (V.I.N.) Number, or chassis number (a). Second, is the engine number. Position (b) is the engine number position on all engines; the engine illustrated is the 1.4 and 1.6 petrol engine. Also, see G4 and G5.

Third, there is the Model and Data Plate (c). See G3.

G2: Fourth, you will need the Paint Identification Plate if you need to buy paint. You'll find it on the inside of the hatchback door. The numbers shown on the plate give the following information: 1 -

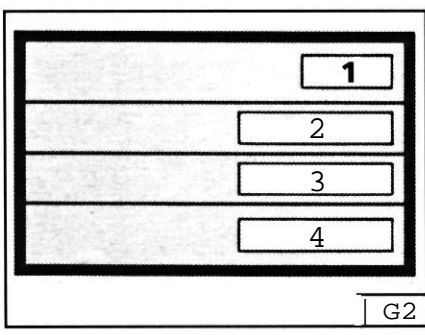

Paint manufacturer; 2 - Colour name; 3 - Colour code; 4 - Respray and touch-up code.

Vehicle Identification Numbers

See illustration G1, part a. There are two groups of codes which are unique to your car. You should never buy a car without checking first that the V.I.N. shown on the car matches

that on the vehicle registration document. The vehicle code is also shown at position c on the Model and Data Plate and the chassis serial number is also shown at position a.

Model and Data Plate

G3: The numbers stamped on the plate stand for the following:
 A- Manufacturer;
 B - Homologation number;
 C - Vehicle identity code;
 D - Chassis serial number;
 E - Maximum

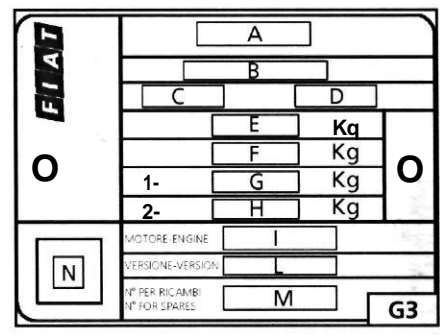

authorised weight of vehicle, fully laden; F - Maximum authorised weight of vehicle, fully laden plus trailer; G - Maximum authorised weight on front axle; H - Maximum authorised weight on rear axle; I - Engine type; L - Body code (see below); M - Number for buying spares; N - Smoke opacity index (diesel engines only).

Engine Numbers

G4: On all petrol engines, the number is on the top of the crankcase at the gearbox end.

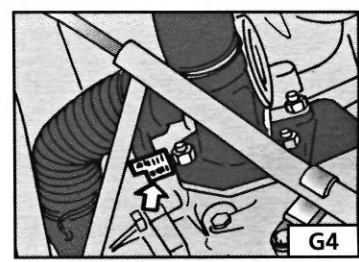

G5: On diesel engines, look on the crankcase, above the water pump housing.

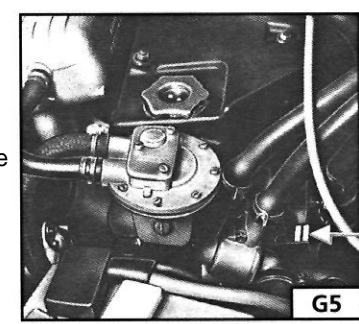

Please read the whole of the CHAPTER 1, SAFETY FIRST! before carrying out any work on your car.

CHAPTER 4 GETTING THROUGH THE MOT

This chapter is for owners in Britain whose vehicles need to pass the 'MoT' test. Obviously, you won't be able to examine your car to the same degree of thoroughness as the MoT testing station. But you can reduce the risk of being one of the 4 out of 10 who fail the test first time by following this check-list.

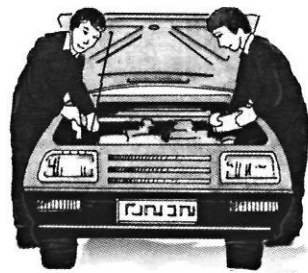

The checks shown below are correct at the time of writing but do note that they are becoming stricter all the time. Your local MoT testing station will have the latest information, should you need it.

| Chapter Contents | | | |
|-------------------------------|----------|---------------------------------------|----------|
| | Page No. | | Page No. |
| PART A: INSIDE THE CAR | 28 | PART C: VEHICLE RAISED OFF THE GROUND | 30 |
| PART B: VEHICLE ON THE GROUND | 29 | PART D: EXHAUST EMISSIONS | 31 |

PART A: INSIDE THE CAR

Steering Wheel and Column

- O 1. Try to move the steering wheel towards and away from you and then from side to side. There should be no appreciable movement or play. Check that the steering wheel is not loose on the column.
- O 2. Lightly grip the steering wheel between thumb and finger and turn from side to side. **Cars with a steering rack:** free play should not exceed approximately 13 mm (0.5 in.), assuming a 380 mm (15 in.) diameter steering wheel. **Cars fitted with a steering box:** free play should not exceed approximately 75 mm (3.0 in.), assuming a 380 mm (15 in.) diameter steering wheel.
- O 3. If there is a universal joint at the bottom of the steering column inside the car, check for movement. Place your hand over the joint while turning the steering wheel to-and-fro a little way with your other hand. If ANY free play can be felt, the joint must be replaced.
- O 4. Ensure that there are no breaks or loose components on the steering wheel itself.

Electrical Equipment

- O 5. With the ignition turned on, ensure that the horn works okay.
- O 6. Check that the front wipers work.
- O 7. Check that the windscreen washers work.

- O 8. Check that the internal warnings for the indicator and hazard warning lights work okay.

Checks With An Assistant

- O 9. Check that the front and rear side lights and number plate lights work and that the Senses and reflectors are secure, clean and undamaged.
- O 10. Check the operation of the headlights (you won't be able to check the alignment yourself) and check that the lenses are undamaged. The reflectors inside the headlights must not be tarnished, nor must there be condensation inside the headlight
- O 11. Turn on the ignition and check the direction indicators, front and rear and on the side markers.
- O 12. Check that the hazard warning lights operate on the outside of the vehicle, front and rear.
- O 13. Check that the rear fog light/s, including the warning light inside the car, all work correctly.
- O 14. Check that the rear brake lights work correctly. These checks are carried out all around the vehicle with all four wheels on the ground.
- O 15. Operate the brake lights, side lights and each indicator in turn, all at the same time. None should affect the operation of the others.

SAFETY FIRST!

- Follow the Safety information in CHAPTER 1, SAFETY FIRST! but bear in mind that the vehicle needs to be even more stable than usual when raised off the ground.
- There must be no risk of it toppling off its stands or ramps while suspension and steering components are being pushed and pulled in order to test them.

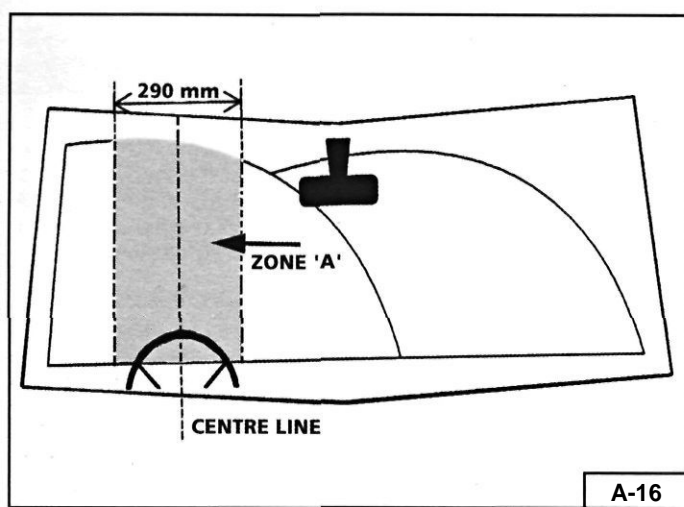

O 20. Pull on the handbrake. It should be fully ON before the handbrake reaches the end of its travel.

O 21. Knock the handbrake from side to side and check that it does not then release itself.

O 22. Check the security of the handbrake

mountings and check the floor around it for rust or splits.

O 23. Check that the brake pedal is in good condition and that, when you take hold of it and move it from side to side, there is not too much play.

O 24. Push the footbrake down hard, with your foot. If it creeps slowly down to the floor, there is probably a problem with the master cylinder. Release the pedal, and after a few seconds, press down again. If the pedal feels spongy or it travels nearly to the floor, there is air in the system or another MoT-failing fault with the brakes.

O 25. Check the servo unit (when fitted) as follows: Pump the pedal several times then hold it down hard. Start the engine. As the engine starts, the pedal should move down slightly. If it doesn't the servo or the vacuum hose leading to it may be faulty.

Seat Belts and Seats

O 26. Examine all of the webbing (pull out the belts from the inertia reel if necessary) for cuts, fraying or deterioration.

O 27. Check that each inertia reel belt retracts correctly.

O 28. Fasten and unfasten each belt to ensure that the buckles work correctly.

O 29. Tug hard on each belt and inspect the mountings, as far as possible, to ensure that all are okay.

IMPORTANT NOTE: Checks apply to rear seat belts as much as front ones.

O 30. Make sure that the seat runners and mountings are secure and that the back rest locks in the upright position.

Doors and Door Locks

O 31. Check that both front doors latch securely when closed and that both can be opened and closed from both outside and inside the car.

Windscreen and Mirrors

O 16. In zone 'A' of your windscreen, no items of damage larger than 10 mm in diameter will be allowed. In the rest of the area swept by the windscreen wipers, no damage greater than 40 mm in diameter will be allowed, nor should windscreen stickers or other obstructions encroach on this area.

O 17. Check that the exterior mirror on the driver's side is in good condition.

O 18. There must be one other mirror in good condition, either inside the car or an external mirror on the passenger's side.

Brakes

O 19. You cannot check the brakes properly without a rolling road brake tester but you can carry out the following checks:

PART B: VEHICLE ON THE GROUND

Electrical Equipment

See **Part A: INSIDE THE CAR** for checks on the operation of the electrical equipment.

O 1. Examine the wiper blades and replace those that show any damage.

Vehicle Identification Numbers (VIN)

O 2. The VIN (or chassis number on older vehicles) must be clearly displayed and legible.

O 3. Number plates must be secure, legible and in good condition with correct spacing between letters and numbers- Any non-standard spacing will not be accepted.

Braking System

O 4. Inside the engine bay inspect the master cylinder, servo unit (if fitted), brake pipes and mountings. Look for corrosion, loose fitting or leaks.

Steering and Suspension

O 5. While still in the engine bay, have your assistant turn the steering wheel lightly from side to side and look for play in steering universal joints or steering rack mountings and any other steering connections.

O 6. If your vehicle is fitted with power steering, check the security and condition of the steering pump, hoses and drivebelt, in the engine bay.

O 7. Look and reach under the car while your assistant turns the steering wheel more vigorously from side to side. Place your hand over each track rod end in turn and inspect all of the steering linkages, joints and attachments for wear.

O 8. Go around the vehicle and 'bounce' each corner of the vehicle in turn. Release at the lowest point and the vehicle should rise and settle in its normal position without continuing to 'bounce' of its own accord.

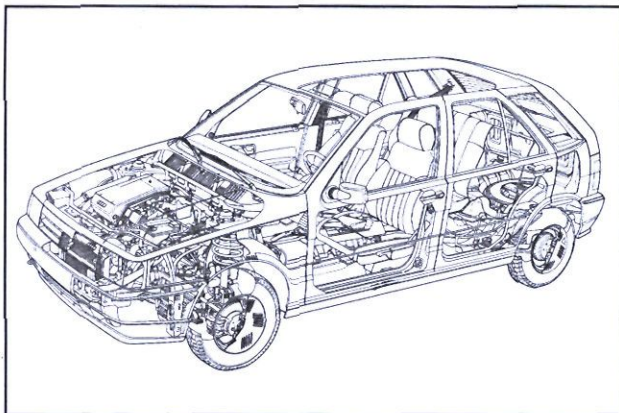

Detailed Contents are shown at the start of each chapter.

CONTENTS

| | | |
|-------------------|--|-----|
| | <i>Auto-Biography</i> | 1 |
| CHAPTER 1: | <i>Safety First!</i> | 5 |
| CHAPTER 2: | <i>Using Your Car</i> | 9 |
| CHAPTER 3: | <i>Facts and Figures</i> | 17 |
| CHAPTER 4: | <i>Getting Through the MoT</i> | 28 |
| CHAPTER 5: | <i>Servicing Your Car</i> | 32 |
| CHAPTER 6: | <i>Repairs and Replacements</i> | 64 |
| | <i>Spark Plug Conditions and Recommended Lubricants</i> .. | 154 |
| CHAPTER 7: | <i>Wiring Diagrams</i> | 155 |
| | <i>Index</i> | 176 |



FACT FILE: 'LEFT AND 'RIGHT' SIDES OF THE CAR

- Throughout this manual, we refer to the 'left' and 'right' sides of the car. They refer to the sides of the car that you would see if you were sitting in the driver's seat, looking forwards.

PART C: VEHICLE RAISED OFF THE GROUND

Bodywork Structure

O 1. Any sharp edges on the external bodywork, caused by damage or corrosion will cause the vehicle to fail.

O 2. Check all load bearing areas for corrosion. Open the doors and check the sills inside and out, above and below. Any corrosion in structural metalwork within 30 cm (12 in.) of seat belt mounting, steering and suspension attachment points will cause the vehicle to fail.

Wheels and Tyres

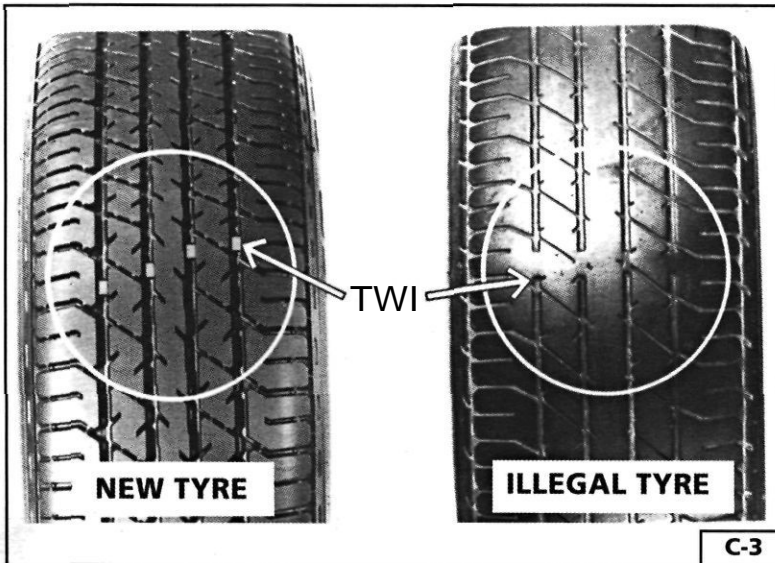

O 3. To pass the test, the tread must be at least 1.6 mm deep throughout a continuous band comprising the central three-quarters of the width of the tread. The Tread Wear Indicators (TWI) will tell you when the limit has been reached, on most tyres.

IMPORTANT NOTE: Tyres are past their best, especially in wet conditions, well before this point is reached!

O 4. Check that the front tyres match and that the rear tyres match each other - in terms of size and type but not necessarily make. They must be the correct size for the vehicle and the pressures must be correct.

O 5. With each wheel off the ground in turn, check the inside and the outside of the tyre wall for cuts, lumps and bulges and check the wheel for damage. Note that tyres deteriorate progressively over a period of time and if they have degraded to this extent, replace them.

Under the Front of the Car

You will need to support the front of the car on axle stands with the rear wheels firmly chocked in both directions.

O 6. Have your helper turn the steering from lock to lock and check that the steering turns smoothly and that the brake hoses or pipes do not contact the wheel, tyre or any part of the steering or suspension.

O 7. Have your assistant hold down the brake pedal firmly. Check each brake flexible hose for bulges or leaks.

O 8. Inspect all the rigid brake pipes underneath the front of the vehicle for corrosion or leaks and also look for signs of fluid leaks at the brake calipers. Rigid fuel pipes need to be checked in the same way.

O 9. At each full lock position, check the steering rack rubber gaiters for splits, leaks or loose retaining clips.

O 10. Check the track rod end dust covers to make sure they are in place.

O 11. Inspect each constant velocity joint gaiter - both inners and outers - for splits or damage. You will have to rotate each wheel to see the gaiters all the way round.

O 12. Check all of the suspension rubber mountings, including the anti-rollbar mountings (when fitted). Take a firm grip on each shock absorber in turn with both hands and try to twist the damper to check for deterioration in the top and bottom mounting bushes.

O 13. Underneath the front wheel arches, check that the shock absorbers are not corroded, that the springs have not cracked and that there are no fluid leaks down the body of the shock absorber.

O 14. While under the front end of the car, check the front of the exhaust system for security of fixing at the manifold, for corrosion and secure fixing to the mounting points.

O 15. Preferably working with a helper, grasp each front road wheel at the 12 o'clock and 6 o'clock positions and try rocking the wheel. Look for movement or wear at the suspension ball joints, suspension mountings, steering mountings and at the wheel bearing - look for movement between the wheel and hub. Repeat the test by grasping the road wheel at 3 o'clock and 9 o'clock and rocking once more.

O 16. Spin each wheel and check for noise or roughness in the wheel bearing and binding in either the wheel bearing or the brake.

IMPORTANT NOTE: Don't forget that on front wheel drive cars, the gearbox must be in neutral. There will be a certain amount of noise and drag from the drivetrain components.

O 17. If you suspect wear at any of the suspension points, try levering with a screwdriver to see whether or not you can confirm any movement in that area.

O 18. Vehicles fitted with other suspension types such as hydraulic suspension, torsion bar suspension etc. need to be checked in a similar way with the additional point that there must be no fluid leaks or damaged pipes on vehicles with hydraulic suspension.

Underneath the Rear of the Car

O 19. Inspect the rear springs for security at their mounting points and for cracks, severe corrosion or damage.

O 20. Check the rear shock absorbers in the same way as the checks carried out for the fronts.

O 21. Check all rear suspension mounting points, including the rubbers to any locating rods or anti-rollbar that may be fitted.

O 22. Check all of the flexible and rigid brake pipes and the fuel pipes just as for the front of the vehicle.

- 23. Have your assistant press down firmly on the brake pedal while you check the rear brake flexible hoses for bulges, splits or other deterioration.
- 24. Check the fuel tank for leaks or corrosion. Remember also to check the fuel filler cap - a correctly sealing filler cap is a part of the MoT test.
- 25. Examine the handbrake mechanism. Frayed or broken cables or worn mounting points, either to the bodywork or in the linkage will all be failure points.
- 26. Check each of the rear wheel bearings as for the fronts.

- 27. Spin each rear wheel and check that neither the wheel bearings nor the brakes are binding. Pull on and let off the handbrake and check once again to make sure that the handbrake mechanism is releasing.

SAFETY FIRST!

- Only run the car out of doors.
- Beware of burning yourself on a hot exhaust system.

- 28. While you are out from under the car, but with the rear end still raised off the ground, run the engine. Hold a rag over the end of the exhaust

pipe and listen for blows or leaks in the system. You can now get back under the car and investigate further if necessary.

- 29. Check the exhaust system mountings and check for rust, corrosion or holes in the rear part of the system.

- 30. Check the rear brake back plate or calipers (as appropriate) for any signs of fluid leakage.

- 31. Check the insides and the outsides of the tyres as well as the tyre treads for damage, as for the front tyres.

PART D: EXHAUST EMISSIONS

This is an area that is impossible to check accurately at home. However, the following rule-of-thumb tests will give you a good idea whether your car is likely to fail or not.

Q INSIDE INFORMATION: If you feel that your car is likely to fail because of the emission test, have your MoT testing station carry out the emission part of the test first so that if it fails, you don't waste

money on having the rest of the test carried out. **F**

- **1. PETROL ENGINES BEFORE 1 AUGUST 1973 AND DIESEL ENGINES BEFORE 1 AUGUST 1979** only have to pass visible smoke check. Rev the engine to about 2,500 rpm (about half maximum speed) for 20 seconds and then allow it to return to idle. If too much smoke is emitted (in the opinion of the tester) the car will fail.

- **2. DIESEL ENGINES FROM 1 AUGUST 1979** The engine will have to be taken up to maximum revs several times by the tester, so make certain that your timing belt is in good condition, otherwise severe damage could be caused to your engine. If the latter happens, it will be your responsibility!

FACT FILE: VEHICLE EMISSIONS

PETROLENGINED VEHICLES WITHOUT CATALYSER

Vehicles first used before 1 August 1973

- visual smoke check only.

Vehicles first used between 1 August 1973 and 31 July 1986

- 4.5% carbon monoxide and 1,200 parts per million, unburned hydrocarbons.

Vehicles first used between 1 August 1986 and 31 July 1992

- 3.5% carbon monoxide and 1,200 parts per million, unburned hydrocarbons.

PETROLENGINED VEHICLES FITTED WITH CATALYTIC CONVERTERS

Vehicles first used from 1 August 1992 (K-registration on)

- All have to be tested at an MoT Testing Station specially equipped to handle cars fitted with catalytic converters whether or not the vehicle is fitted with a 'cat'. If the test, or the garage's data, shows that the vehicle was not fitted with a 'cat' by the manufacturer, the owner is permitted to take the vehicle to a Testing Station not equipped for catalysed cars, if he/she prefers to do so (up to 1998-only). Required maxima are - 3.5% carbon monoxide and 1,200 parts per million, unburned hydrocarbons. The simple emissions test (as above) will be supplemented by a further check to make sure that the catalyst is maintained in good and efficient working order.
- The tester also has to check that the engine oil is up to a specified temperature before carrying out the test. (This is because 'cats' don't work properly at lower temperatures - ensure *your* engine is fully warm!)

DIESEL ENGINES' EMISSIONS STANDARDS



- The Tester will have to rev your engine hard, several times. If it is not in good condition, he is entitled to refuse to test it. This is the full range of tests, even though all may not apply to your car.

Vehicles first used before 1 August, 1979

- Engine run at normal running temperature; engine speed taken to around 2,500 rpm (or half governed max. speed, if lower) and held for 20 seconds. **FAILURE**, if engine emits dense blue or black smoke for next 5 seconds, at tick-over. (NOTE: Testers are allowed to be more lenient with pre-1960 vehicles.)

Vehicles first used on or after 1 August, 1979

- After checking engine condition, and with the engine at normal running temperature, the engine will be run up to full revs between three and six times to see whether your engine passes the prescribed smoke density test. (For what it's worth - 2.5k for non-turbo cars; 3.0k for turbo diesels. An opacity meter probe will be placed in your car's exhaust pipe and this is not something you can replicate at home.) Irrespective of the meter readings, the car will fail if smoke or vapour obscures the view of other road users.
- **IMPORTANT NOTE:** The diesel engine test puts a lot of stress on the engine. It is **IMPERATIVE** that your car's engine is properly serviced, and the cam belt changed on schedule, before you take it in for the MoT test. The tester is entitled to refuse to test the car if he feels that the engine is not in serviceable condition and there are a number of pre-Test checks he may carry out.

CHAPTER 5 SERVICING YOUR CAR

Everyone wants to own a car that starts first time, runs reliably and lasts longer than the average. And it's all a question of thorough maintenance!

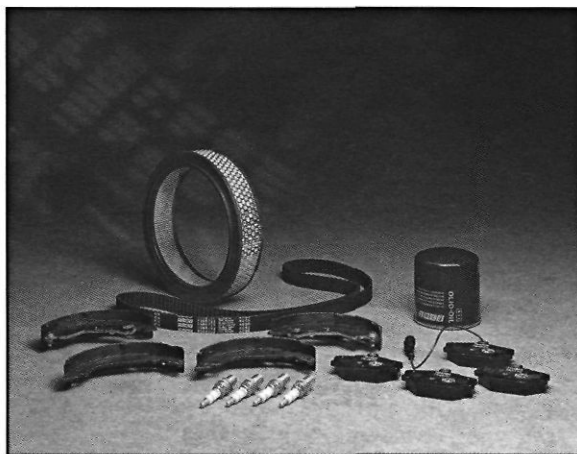

If you follow the FIAT-approved Service Jobs listed here you can almost guarantee that your car will still be going strong when others have fallen by the wayside - or the hard shoulder.

How To Use This Chapter

This chapter contains all of the servicing Jobs recommended by FIAT for all models of Tipo and Tempra imported into the UK except cars with 1.8 and 2 litre DOHC petrol engines. To use the schedule, note that:

- Each letter code tells you the Service Interval at which you should carry out each Service Job.
- Each Service Job has a Job number.
- Look up the number in the relevant part of this chapter and you will see a complete explanation of the work.

SAFETY FIRST!

SAFETYFIRST information must always be read with care and always taken seriously.

- In addition, please read the whole of **Chapter 1, Safety First!** before carrying out any work on your car.
- There are many hazards associated with working on a car but all of them can be avoided by adhering strictly to the safety rules.
- Don't skimp on safety!

SERVICE INTERVALS - INTRODUCTION



Over the years, FIAT, in common with all other manufacturers, have lengthened their recommended service intervals. For instance, oil changes on later FIATs don't have to take place as often as earlier ones. In the main, these changes have not come about because of specific modifications to the cars themselves. They have come about because of a number of factors: Lubricants, spark plugs, seals and other components have improved and mechanical parts are better made due to improved materials and production techniques.

As a result, you are recommended to follow the maker's recommendations on how often to service your car. If your car lies right on a change-over point, the choice of which schedule to follow will be yours, unless the specific advice given here recommends otherwise - as we said earlier, most change points came about for a number of reasons, so it generally isn't necessary to identify with pinpoint accuracy which bracket your car belongs to, if it isn't obvious.

making it easy!

- We think it is very important to keep things as straightforward as possible.

And where you see this heading, you'll know there's an extra tip to help 'make it easy' for you!

Thanks are due to the excellent, knowledgeable and helpful staff at FIAT main dealers, Ryauto of Amblecote, in the West Midlands for supplying vehicles and for their assistance with this chapter. In particular, thanks are due to the efficient Maurice Hough, Service Manager, the experienced Foreman, Tony Morris, and young demon mechanic, Matthew Worsfold.

Some of the suggested inspection/replacement intervals may not correspond to those shown in the original handbook. The suggested schedule, based on FIATS recommendations, takes into account the age of the vehicle and the annual MoT test in the UK.

In practice, because of the split between (mainly) 12 month/9,000 mile and 18 month/13,500 mile intervals, you will need to service your Tipo or Temptra at most, if not every, 6 month interval.

IMPORTANT NOTE: Each service should be carried out at EITHER the recommended mileage OR the recommended time interval, whichever comes first.

SERVICE INTERVAL CHART

SERVICE INTERVALS: KEY

- | | |
|---|------------------------------------|
| A - Every week, or before every long journey. | F - Every 3 years or 27,000 miles. |
| B - Every 6 months, or 4,500 miles. | G - Every 4 years or 36,000 miles. |
| C - Every 12 months, or 9,000 miles. | H - Every 6 years or 54,000 miles. |
| D - Every 18 months, or 13,500 miles. | I - Every 63,000 miles. |
| E - Every 2 years or 18,000 miles. | J - Every 72,000 miles. |

PART A: REGULAR CHECKS

| | SERVICE INTERVALS |
|---|-------------------|
| Job 1. Engine oil - check level | A |
| Job 2. Cooling system-check level | A |
| Job 3. Brake/clutch fluid - check level | A |
| Job 4. Battery - check electrolyte level | A |
| Job 5. Screen washer fluid - check level | A |
| Job 6. Tyres - check pressures and condition (road wheels) | A |
| Job 7. Check lights/change bulbs | A |

PART B: THE ENGINE AND COOLING SYSTEM

| | |
|---|---|
| Job 8 - Petrol. Change engine oil and filter | C |
| Job 8 - Diesel. Change engine oil and filter | B |
| Job 9. Check crankcase ventilation | H |
| Job 10. Check/adjust valve clearances | D |
| Job 11. Check camshaft timing belt | F |
| Job 12. Change camshaft timing belt | I |
| Job 13. Check cooling system | C |
| Job 14. Change engine coolant | E |

PART C: TRANSMISSION

| | |
|---|---|
| Job 15. Check manual gearbox oil level | C |
| Job 16. Change manual gearbox oil | J |
| Job 17. Check auto, transmission fluid level | C |
| Job 18. Change auto, transmission fluid and filter | F |
| Job 19. Check driveshaft gaiters | C |
| Job 20. Check/adjust clutch | C |
| Job 21. Check auto, transmission selector cable | E |

PART D: IGNITION AND ELECTRICS

| | SERVICE INTERVALS |
|---|-------------------|
| Job 22. Check/clean/gap spark plugs | B |
| Job 23. Change spark plugs | D |
| Job 24. Check/clean HT leads and distributor cap | C |
| Job 25. Check ignition timing | C |
| Job 26. Check/adjust drive belt/s | D |
| Job 27. Check electric fan operation | C |
| Job 28. Run diagnostic ignition/injection test | D |

PART E: FUEL AND EXHAUST

| | |
|--|---|
| Job 29. Check fuel pipes for leaks | C |
| Job 30. Change petrol air filter | D |
| Job 31. Change diesel air filter | C |
| Job 32. Change petrol fuel filter | F |
| Job 33. Drain diesel fuel filter | B |
| Job 34. Change diesel fuel filter | C |
| Job 35. Check/adjust petrol engine idle and emissions | C |
| Job 36. Check emission/evaporative/EGR systems | F |
| Job 37. Check Lambda sensor | F |
| Job 38. Check/adjust diesel idle speed | C |
| Job 39. Check/adjust diesel injection timing | B |
| Job 40. Check inlet and exhaust manifold fixings | D |
| Job 41. Check exhaust system | C |

PART F: STEERING AND SUSPENSION

| | |
|---|---|
| Job 42. Check front wheel bearings | C |
| Job 43. Check front suspension | C |
| Job 44. Check steering column, joints and rack | C |
| Job 45. Check power steering fluid | C |
| Job 46. Check rear wheel bearings | C |
| Job 47. Check rear suspension | C |
| Job 48. Check wheel bolts for tightness | C |

PART G: BRAKING SYSTEM

| | SERVICE INTERVALS |
|--------------------------------------|----------------------|
| Job 49. Check front brakes | C |
| Job 50. Check rear brakes | C |
| Job 51. Check/adjust handbrake | C |
| Job 52. Check brake pipes | C |
| Job 53. Change brake hydraulic fluid | E |

PART H: BODYWORK & INTERIOR

| | |
|------------------------------------|---|
| Job 54. Lubricate hinges and locks | C |
| Job 55. Check windscreen | C |

| | |
|--|----------|
| Job 56. Check seat and seat belt mountings | C |
| Job 57. Check headlight alignment | C |
| Job 58. Check underbody | C |
| Job 59. Check spare tyre | B |
| Job 60. Change pollen filter | C |
| Job 61. Replace airbag gas generator | 10 years |

PART I: ROAD TEST

Job 62. Roadtest and specialist check. *AFTER EVERY SERVICE*

ENGINE BAY LAYOUTS

These are the engine bay layouts common to almost all Tipo/Tempras. Note that there is no carburettor fitted to fuel-injected vehicles.

1 - PETROL ENGINES

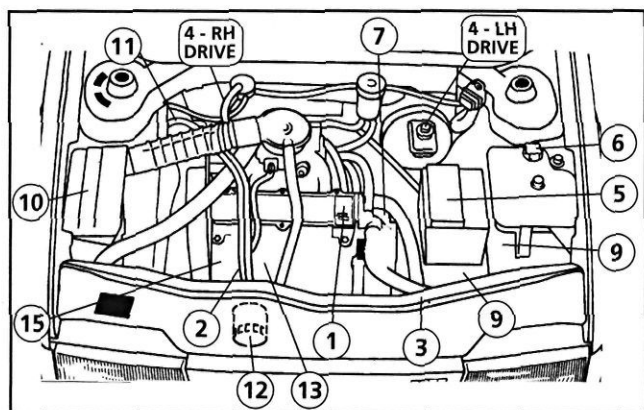

2 - DIESEL ENGINES

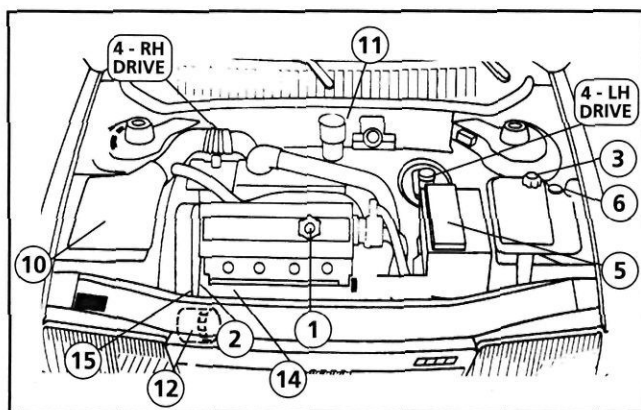

| | | |
|------------------------------|---|--|
| 1 - oil filler cap | 7 - distributor (ignition) | 12 - oil filter location |
| 2 - engine oil dipstick | 8 - coil (ignition) | 13 - fuel pump (mechanical) |
| 3 - coolant filler cap | 9 - electronic control unit (ECU), Digiplex 2 | 14 - diesel injection pump |
| 4 - brake fluid reservoir | 10 - air filter housing | 15 - alternator location (behind engine) |
| 5 - battery | 11 - fuel filter | |
| 6 - screenwash reservoir cap | | |

PART A: REGULAR CHECKS

We recommend that these Jobs are carried out on a weekly basis, as well as before every long journey. They consist of checks essential for your safety and for your car's reliability,

L) Job 1. Engine oil - check level.

Check the engine oil level with the car on level ground. If the engine has been running, leave it turned off for several minutes to let the oil drain into the sump.

1A. All petrol engines have the dipstick at the front of the block, towards the timing belt end...



1B. ...and the diesel's dipstick is in a similar spot, located at the front edge of the timing cover, behind the right-hand headlight.

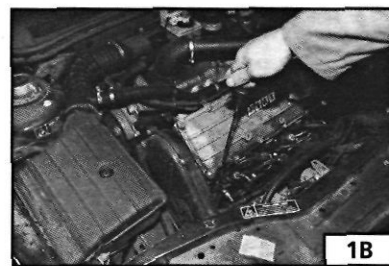

1C. Lift the dipstick out, wipe it dry and re-insert it. The oil level is correct when between the MAX and MIN marks.

B INSIDE INFORMATION: The difference between MIN and MAX marks is approximately one litre of oil. **L**

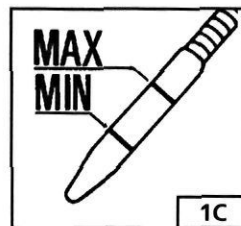

TOPPING-UP

ID. On petrol engines the oil filler cap is pull-out rectangular plug at the end of the rocker cover adjacent to the distributor. Note that on some models, the cap is circular.

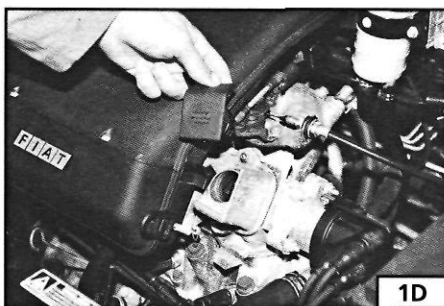

On diesel engines, the round cap is near the same end of the cam cover. This cap is removed by turning a quarter-turn to the left and lifting.

IE. Pour in the fresh oil carefully, preferably using a funnel. A clean plastic bottle with the bottom cut off is ideal!

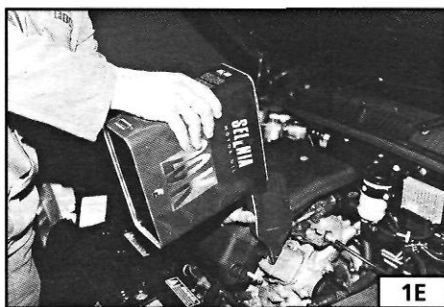

IMPORTANT NOTE: Regularly check the ground over which the car has been parked for traces of oil or other fluid leaks. If a leak is found, don't drive the car without first finding out where the leak is from, and ideally, repairing it.

U Job 2. Cooling system - check level.

SAFETY FIRST!

- ALWAYS check the coolant level with the engine COLD
- If the engine is hot there is a real danger of scalding from boiling coolant gushing from the tank when the cap is removed.

Never allow the coolant level to fall below the MIN (or LIVELLO A FREDDO) mark on the expansion tank. It is vitally important that all engines have the correct proportion of anti-freeze in the coolant all year round to prevent corrosion. A 50% mix of distilled water with FL Parafu coolant gives the best protection.

PETROL ENGINES

2A. The coolant should be just below the remote header tank filler neck - about 25 mm (1 in) above the MIN (or LIVELLO A FREDDO) mark on the tank (arrowed). This is the header tank (screw-on cap, removed), on the passenger-side of the engine bay, at the very front of the engine bay.

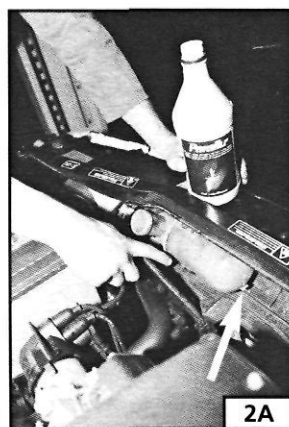

DIESEL ENGINES

2B. Check the level as described in **Job 2A**.

Unscrew the coolant filler cap anti-clockwise and remove it. DON'T confuse the coolant cap with the smaller windscreen washer fluid cap, to one side of it.



Top-up, if necessary using a 50:50 mixture of distilled water and Parafu anti-freeze.

• Job 3. Brake/clutch fluid - check level/s.

IMPORTANT NOTE: On later models, a hydraulic clutch is fitted. The same fluid reservoir serves both brakes and clutch.

SAFETY FIRST!

- If brake fluid should come into contact with skin or eyes, rinse immediately with plenty of water.
- It is acceptable for the brake fluid level to fall slightly during normal use, but if it falls significantly below the MIN mark on the reservoir there is probably a leak or internal seal failure. Stop using the car until the problem has been put right
- If you let dirt get into the hydraulic system it can cause brake failure. Wipe the filler cap clean before removing it
- You should only ever use new brake fluid from a sealed container - FIAT recommend FL Tutela Top 4 brake fluid. Old fluid absorbs moisture and this could cause the brakes to fail when carrying out an emergency stop or during another heavy use of the brakes - just when you need them most and are least able to do anything about it, in fact!

On all models the brake fluid reservoir is positioned above the master cylinder either in the rear right-hand or rear left-hand corner of the engine bay, according to model. The reservoir is semi-transparent so the level can be checked without disturbing the cap.

3. If brake fluid topping-up is required, turn the cap without allowing the centre section to turn. This section, with two wires attached, swivels in the cap. Place the cap and float to one side - take care not to drip fluid from the float - and top up with FL Tutela Top 4 brake and clutch fluid.

Check that the brake fluid-level warning-light is operating. Turn the ignition key to the MAR

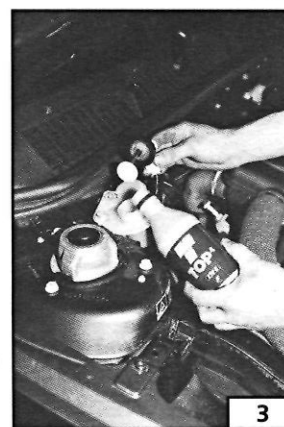

(ignition-ON) position and press down the button between the two terminals on the reservoir cap - when fitted. The warning light on the dash should light up. When no button is fitted, unscrew and raise the cap (ignition key ON) to check the warning light. Check the bulb, check the fuse, or have your FIAT dealer repair the warning system, if faulty.

Q Job 4. Battery - check electrolyte level.

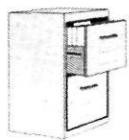

FACT FILE: DISCONNECTING THE BATTERY

- Many vehicles depend on a constant power supply from the battery; with these you find yourself in trouble if you simply disconnect the battery. You

might find the car alarm goes off, or that the engine management system forgets all it ever 'learned', making the car feel odd to drive until it has re-programmed itself. You might also find that the radio refuses to operate until its correct security code is keyed into it.

- On cars with engine management systems and/or coded radios, you must ensure the car has a constant electrical supply, even with the battery removed. You will need a separate 12 volt battery; put a self-tapping screw into the positive lead near the battery terminal before disconnecting it, and put a positive connection to your other battery via this screw.

- Be **EXTREMELY CAREFUL** to wrap insulation tape around the connection so that no short is caused. The negative terminal on the other battery must be connected to the car's bodywork.

SAFETY FIRST!

- *The gas given off by a battery is highly explosive. Never smoke, use a naked flame or allow a spark in the battery compartment*
- *Never disconnect the battery (it can cause sparking) with the battery caps removed.*
- *All vehicle batteries contain sulphuric acid. If the acid comes into contact with the skin or eyes, wash immediately with copious amounts of cold water and seek medical advice,*
- *Do not check the battery levels within half an hour of the battery being charged with a separate battery charger because the addition of fresh water could cause electrolyte to flood out*

4. Check the electrolyte level in the battery. MAX and MIN lines (arrowed) are moulded into the translucent battery casing. In the case of non-FIAT-supplied batteries, the cell caps or strip (a) may need to be removed to see the level.

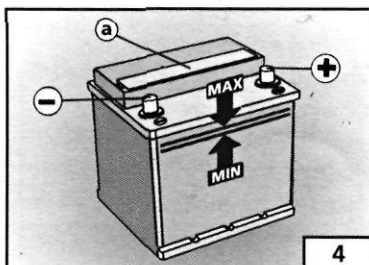

Original FIAT batteries are of the 'maintenance-free' type and usually do not need topping-up. However, if necessary, top up after prising off the cell sealing strip with a screwdriver. Top-up each cell **ONLY** with distilled or de-ionised water.

L) Job 5. Screen/headlight washer fluid - check level.

5A. Top up with a mixture of water and screen-wash additive, mixed according to the instructions on the container. FIAT recommend **Arexons DP1**. The reservoir for front screen, rear screen and headlights (as appropriate) is situated in the engine bay: adjacent to the left-hand strut, behind the battery...

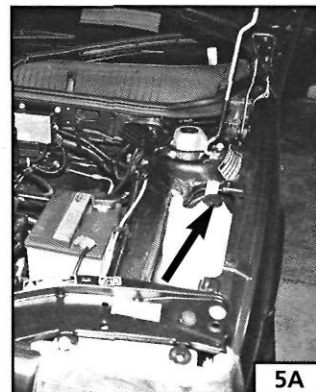

5B. ...and behind the coolant expansion tank on diesel models, as illustrated here.

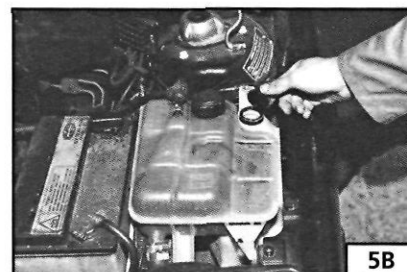

Q Job 6. Tyres - check pressures and condition (road wheels).

6A. Check the tyre pressures using a reliable and accurate gauge. Note that the recommended pressures (see Chapter 3, Facts and Figures) are given for **COLD** tyres. Tyres

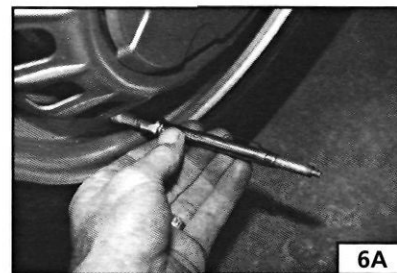

warm up as the car is used - and warm tyres give a false (high) reading. You should also check for wear or damage at the same time.

SAFETY FIRST!

- *If a tyre is worn more on one side than another, consult your FIAT dealer or a tyre specialist. It probably means the tracking needs re-setting, though it could indicate suspension damage, so have it checked.*
- *If a tyre is worn more in the centre or on the edges, this indicates incorrect tyre pressures.*
- *Incorrectly inflated tyres wear rapidly, can give dangerous handling, and can worsen fuel consumption.*

6B. Every few weeks, examine the tyre treads for wear using a tread-depth gauge. This will help you keep safe and on the right side of the law! Check treads visually every time you check the pressures.



Every three months, raise each wheel off the ground and turn it slowly between your

hands, looking and feeling for any bulges, tears or splits in the tyre walls, especially the inner sidewalls. (See **Job 59** for spare tyre checks.)

B INSIDE INFORMATION: In time, rubber deteriorates, increasing the risk of a blow-out. Keep your eye on the sidewalls of older tyres. If you see **any** cracking, splits or other damage scrap the tyre. If you're not sure, consult your FIAT dealer or tyre specialist. **Q**

J Job 7. Check lights/change bulbs.

Whenever a light fails to work, check its fuse before replacing the bulb.

- A blown bulb often causes a fuse to 'go' in sympathy.

HEADLIGHTS

IMPORTANT NOTE: On Diesel models with the air filter mounted behind the right-hand headlight unit, you will first have to remove the large hose, unscrew the clamp nut and take off the air filter assembly. See **Job 31**. On later models, there is sometimes an air intake silencer in the same place.

7A. Pull off the headlight multi-plug (A) and peel the rubber cover (B) from the back of the headlight.

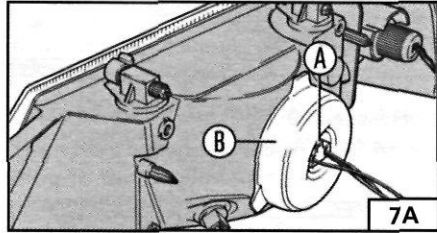

7B. Unhook the bulb securing spring (C) from the retention clip by squeezing inwards (arrowed) and withdraw the bulb (D).

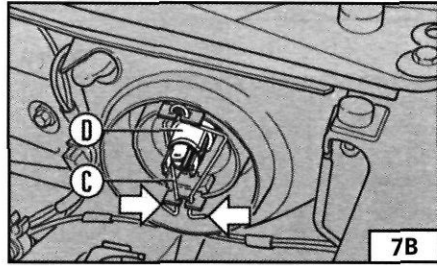

Without touching the bulb glass, fit the new bulb. A locating tag ensures it only goes in in the correct position. Refit and reconnect in the reverse order.

making it easy!

- If you touch a halogen headlight (or driving light) bulb with bare fingers you will shorten its life, so handle with a piece of tissue paper. If the bulb is touched, wipe it carefully with methylated spirit.

FRONT SIDE LIGHTS

7C. The side light bulb holder is under the main headlight bulb. The bayonet-type

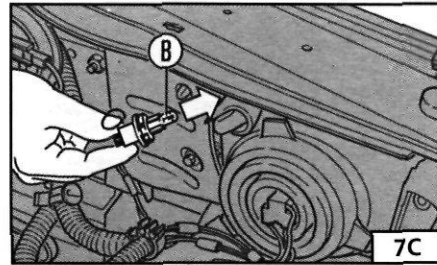

holder is pushed in slightly, turned anti-clockwise and removed. The bulb (B) is a push-fit within it.

FRONT DIRECTION INDICATORS - TURBO DIESEL MODELS

7D. Remove the lens (B) by inserting a screw-driver as shown and pressing down and turning the tab (A). You can easily remove the bulbs with the lens removed.

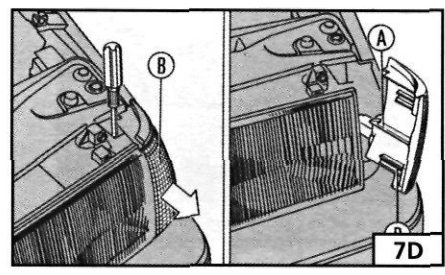

FRONT DIRECTION INDICATORS - ALL OTHER MODELS

7E. From inside the engine bay, turn the bulbholder slightly, anti-clockwise, and pull out. Remove the bulb (B) and press in a new one. Push in and twist clockwise.

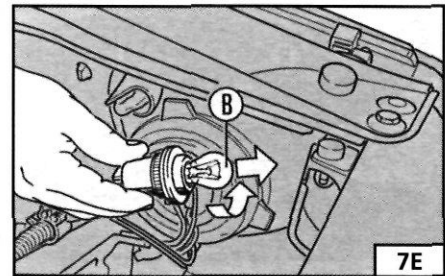

INDICATOR SIDE REPEATERS - RECTANGULAR TYPE

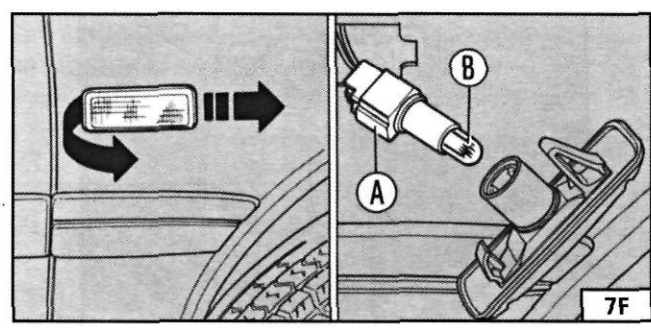

7F. Slide the unit towards the front of the car, then pull out from the panel. Turn the bulbholder (A) anti-clockwise, remove it, and pull out the press-fit 12V/5W bulb.

INDICATOR SIDE REPEATERS - ROUND TYPE

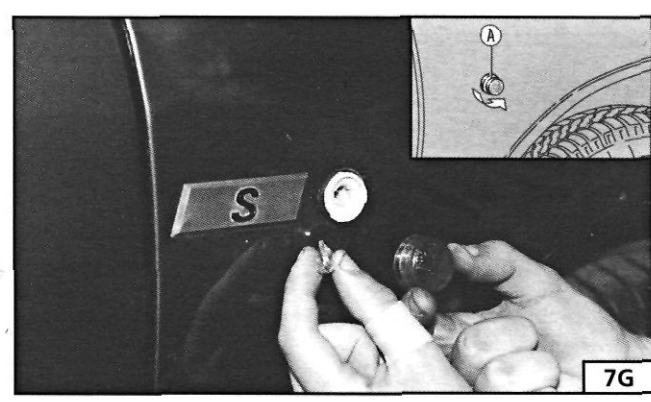

7G. Twist the lens (A) anti-clockwise and remove it. The push-in bulb can be pulled out and replaced.

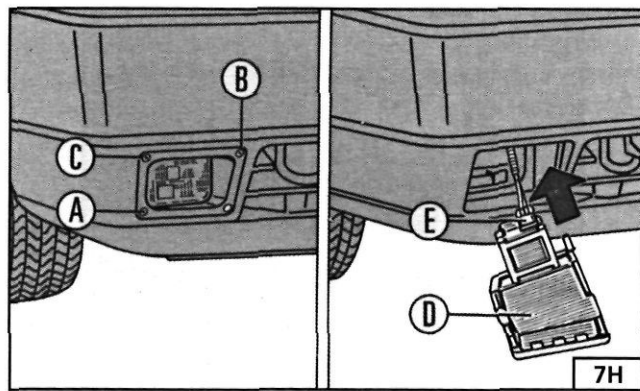

7H. Undo screws (A) and (B), pull out the light unit (D) and undo the connector (E). The height of the beam can later be adjusted with screw (C).

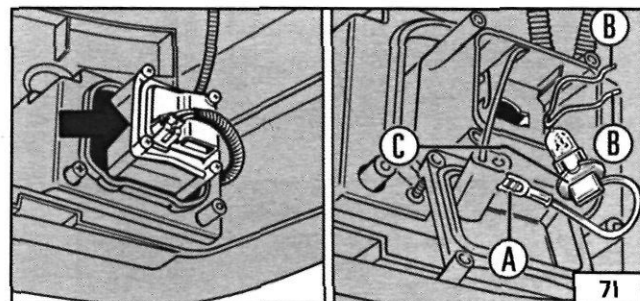

7I. Alternatively: Work from under the front of the car, leaving the unit in place.

Undo the four screws holding the cover in place. Note that you do not need to remove the electrical connection from the cover. On one version of these lights, you have to release the ends of the spring clips (B) and swing them back to remove the bulb.

7J. On another version, you unhook the bulb retainer (G), remove the bulb and disconnect the bulb cable (L). When refitting, ensure that the cut-out in the bulb base-plate (H) is located correctly.

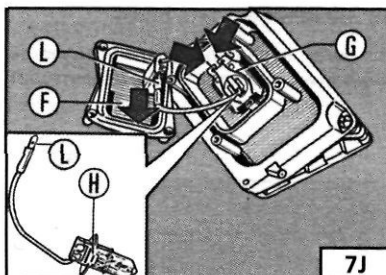

REAR LIGHTS - TIPO

7K. Open the hatchback door and remove the three screws (arrowed) holding the lens in place.

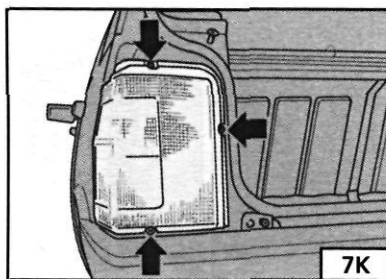

7L. From the inner side of the light unit, take out the two screws (arrowed) holding the lens to the unit. Take care not to strain the wiring.

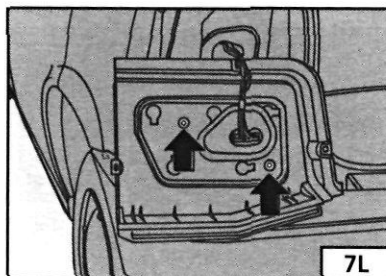

- A - reversing light bulb(21W)
- B - direction indicator bulb (21W)
- C - stop light bulb (21W)
- D - taii-light bulb (5W)
- E - fog light bulb (21W)

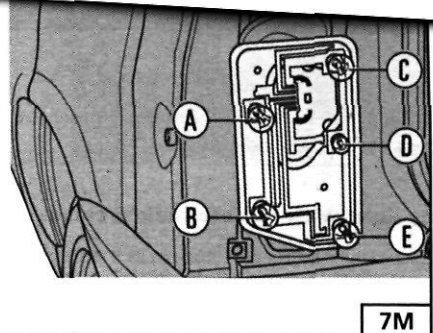

7M. These are the positions of the bulbs. All of the bulbs are released by pushing in slightly, turning anti-clockwise and pulling out when free.

REAR LIGHTS - TEMPRA SALOON

7N. Open the boot lid and remove the screw (F).

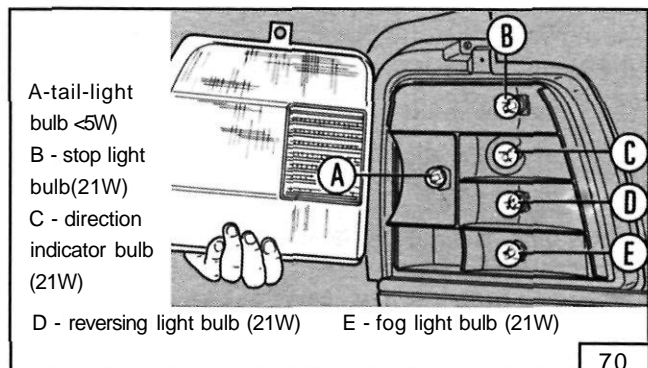
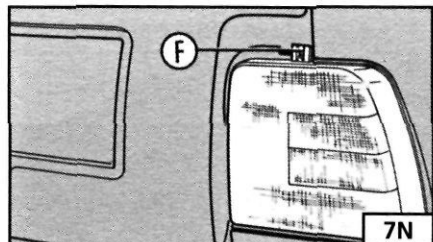

7O. Lift the lens away. The bulbs are removed as described in 7M.

REAR LIGHTS - TEMPRA ESTATE

7P. Open the tailgate door and remove the two screws (A).

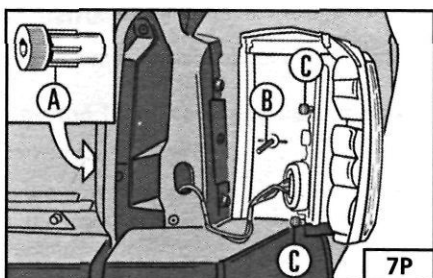

From inside the car, remove the spare wheel, if fitted, open the side compartment and remove its covers. Unscrew the knurled nut (A) which fits on to the captive screw (B) mounted on the lens. Use your other hand to prevent the lens from falling. Now, pull off the lens and remove the two knurled nuts (C) to give you access to the bulb holder.

making it easy! • Use a magnetic screwdriver or place some thick grease on the end of the screwdriver to prevent the screws from falling - especially when replacing the lens.

D - dual filament stop and tail-light bulb (5W-21W). Take careful position of the offset pegs on the shank of the bulb when refitting.
 E - direction indicator bulb (21W)
 F - reversing light bulb (21W)
 G - fog light bulb (21W)

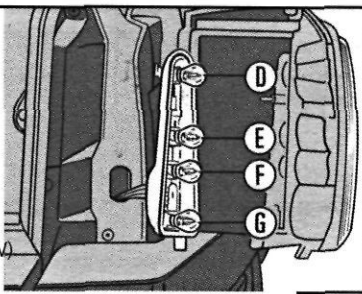

7Q

7Q. All of the bulbs are removed as described in 7M.

NUMBER PLATE LIGHT - TIPO

7R. Insert a screwdriver blade in the slot (arrowed) on the side of lens to depress the tab (A) and pull the assembly (B) outwards to release it. Remove and replace the tubular 5W bulb (C).

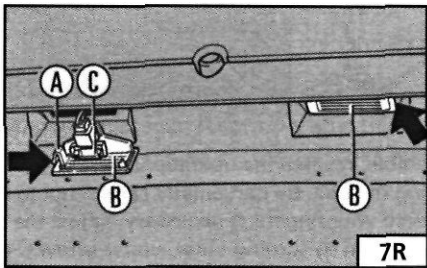

7R

NUMBER PLATE LIGHT - TEMPRA

7S. Remove the complete unit by placing a screwdriver under the right-hand edge. Press the unit to the left, in the direction of the straight arrow, while lifting it out. The tubular 5W bulb is undipped and replaced - see inset.

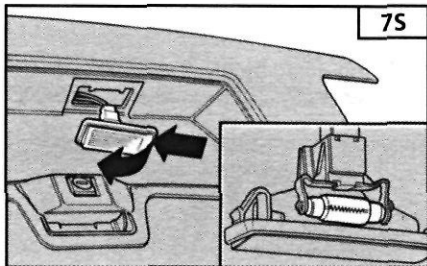

7S

INTERIOR LIGHTS - TIPO

7T. **WITHOUT FIAT REMOTE LOCKING:** Remove the interior light lens by placing a screwdriver in its side-notches (arrowed). Replace the 5W cylindrical bulb or bulbs (A), and/or the 5W capless bulb (B) if your car has a map light.

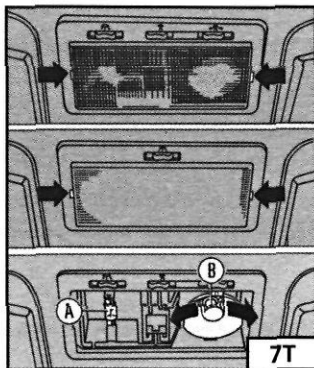

7T

7U. **WITH FIAT REMOTE LOCKING:** Place a screwdriver in the position shown by the arrow (furthest from the receiving unit). Push the courtesy light unit towards the receiver, then pull it downwards to remove.

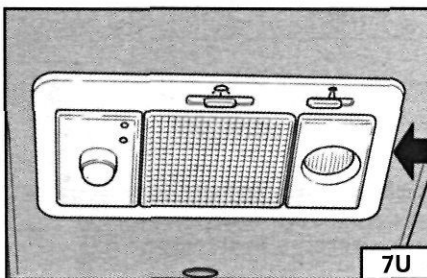

7U

7V. Swing the cover lens away (C) and replace the 5W cylindrical bulb (A) or 5W halogen bulb (B) with bayonet fitting, as necessary.

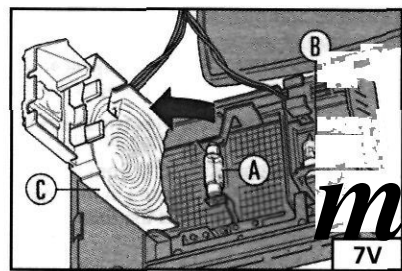

7V

INTERIOR LIGHTS - TEMPRA

7W. WITHOUT SUNROOF:

Remove the lens by levering carefully with a screwdriver under either side - NOT the front or back. Remove the reflector (C) by pressing gently on the two tabs. The capless 5W bulb (B) can now easily be pulled out. The 5W tubular bulb (A) is held in place by its spring clips.

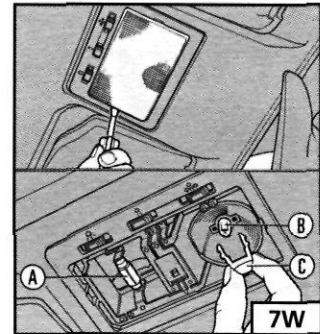

7W

7X. WITH POWER SUNROOF:

Remove the lens as described in 7W. The tubular bulbs (A) can be replaced as described in 7W. To replace the map light (B) bulb you must first remove the plastic cover - place a screwdriver under the points indicated by the arrows. Now undo the two screws at (C) and the single screw at (D).

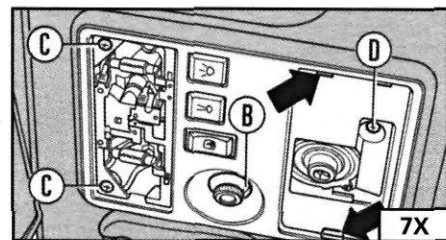

7X

7Y. The entire courtesy light unit is now removed and the 5W capless bulb (E) can now be removed and replaced from the rear of the unit.

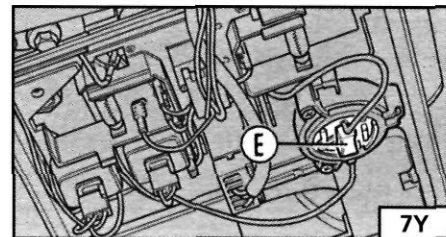

7Y

7Z. Rear interior light bulbs are replaced in a similar way to the tubular bulb described in 7W.

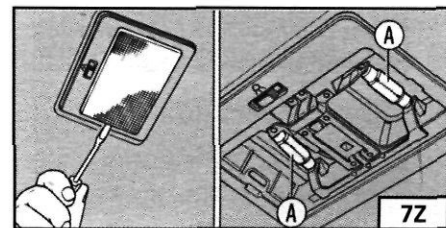

7Z

GLOVE COMPARTMENT LIGHT

7a. From inside the glove compartment, press gently on the side shown by the arrow, remove the entire unit and replace the bulb (A).

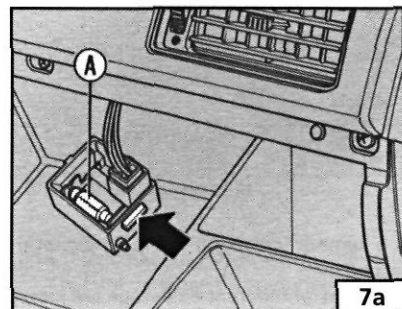

7a

CHAPTER 1 SAFETY FIRST!

You must always ensure that safety is the first consideration in any job you carry out. A slight lack of concentration, or a rush to finish the job quickly can easily result in an accident, as can failure to follow the precautions outlined in this manual.

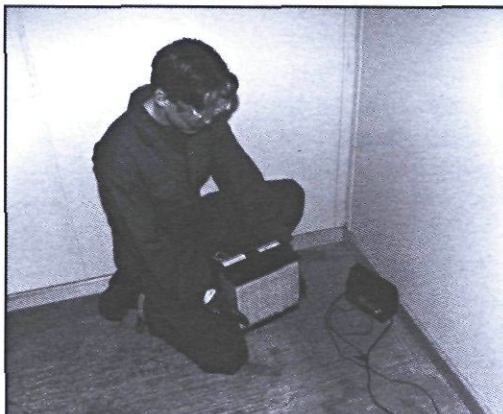

Be sure to consult the suppliers of any materials and equipment you may use, and to obtain and read carefully any operating and health and safety instructions that may be available on packaging or from manufacturers and suppliers.

GENERAL

Raising the Car Safely

ALWAYS ensure that the vehicle is properly supported when raised off the ground. Don't work on, around, or underneath a raised vehicle unless axle stands are positioned under secure, load bearing underbody areas, or the vehicle is driven onto ramps, with the wheels remaining on the ground securely chocked to prevent movement.

NEVER work on a vehicle supported on a jack. Jacks are made for lifting the vehicle only, not for holding it off the ground while it is being worked on.

ALWAYS ensure that the safe working load rating of any jacks, hoists or lifting gear used is sufficient for the job, and that lifting gear is used only as recommended by the manufacturer.

NEVER attempt to loosen or tighten nuts that require a lot of force to turn (e.g. a tight oil drain plug) with the vehicle raised, unless it is safely supported. Take care not to pull the vehicle off its supports when applying force to a spanner. Wherever possible, initially slacken tight fastenings before raising the car off the ground.

ALWAYS wear eye protection when working under the vehicle and when using power tools.

Working On The Vehicle

ALWAYS seek specialist advice unless you are justifiably confident about carrying out each job. The safety of your vehicle affects you, your passengers and other road users.

DONT lean over, or work on, a running engine unless it is strictly necessary, and keep long hair and loose clothing well out of the way of moving mechanical parts. Note that it is theoretically possible for fluorescent striplighting to make an engine fan appear to be stationary - double check whether it is spinning or not! This is the sort of error that happens when you're really tired and not thinking straight. So...

...DONT work on your car when you're over tired.

ALWAYS work in a well ventilated area and don't inhale dust - it may contain asbestos or other harmful substances.

NEVER run the engine indoors, in a confined space or over a pit.

REMOVE your wrist watch, rings and all other jewellery before doing any work on the vehicle - and especially when working on the electrical system.

DONT remove the radiator or expansion tank filler cap when the cooling system is hot, or you may get scalded by escaping coolant or steam. Let the system cool down first and even then, if the engine is not completely cold, cover the cap with a cloth and gradually release the pressure.

NEVER drain oil, coolant or automatic transmission fluid when the engine is hot. Allow time for it to cool sufficiently to avoid scalding you.

ALWAYS keep antifreeze, brake and clutch fluid away from vehicle paintwork. Wash off any spills immediately.

TAKE CARE to avoid touching any engine or exhaust system component unless it is cool enough not to burn you.

LUGGAGE COMPARTMENT LIGHT

7b.TIPO: Pull the lens downwards to remove it. Remove and replace the 5W tubular bulb.

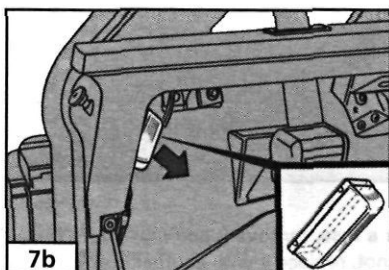

7c. TEMPRA SALOON:

From inside the boot, lever the light unit out of its slot with a screwdriver. Remove and replace the 5W tubular bulb (A).

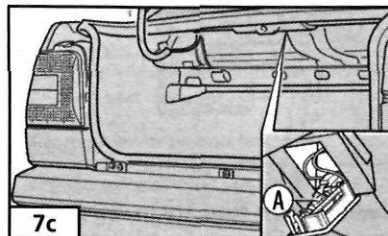

DASH BULBS

See **Chapter 6, Repairs and Replacements** for details of instrument panel removal for access to its light bulbs. The bulbs are a quarter-turn fit in the back of the panel.

FACT FILE: FUSES



• 7d. The fuse box is found to the side of the steering column. Pull the lever marked FUSE...



• ...and lower the fuse box.

• 7e. A symbol above each fuse tells you which circuit it protects. Four spare fuses are located near the top of the fuse box.

10A Instrument power supply, windscreen washer pump, rear screen washer pump, reverse lights, steering column switch lights, FIAT CODE system.

10A Instrument power supply, left tail light, right number plate light, right side light, left trailer tail light.

10A Illumination of controls, right tail light, left number plate light, right tail light.

20A Horns, cigarette lighter, stop lights.

20A Power locks.

7.5A Interior lighting.

20A Rear window heater and indicator light, door mirror defogging elements (if fitted).

10A Hazard warning lights.

25A Electrical fan for radiator cooling (only for petrol versions without air conditioner).

7.5A Direction indicators, right door power mirror (if fitted).

7.5A Rear fog-guard lights and panel indicator.

20A Front fog lights and panel indicator (if fitted).

10A Right low beam headlight.

10A Left low beam headlight.

SERVIZI
SERVICES



10A Left high beam headlight and panel indicator.

10A Right high beam headlight.

20A Windscreen wiper.

20A Read window wiper, power sunroof and heated seat (if fitted).

20A Heater/ventilation fan.



Fuses located on the auxiliary panel

The fuses protecting special devices (options, features of special versions or devices with high power requirements) are on an auxiliary panel to the side of the fuse box under the dashboard. It is much easier to remove and replace auxiliary panel fuses if you first remove the oddment tray and moulding fastened by 5 screws. The panel also houses a number of relays:

20A Intake manifold heater (petrol engines).

20A Diesel fuel filter heater (diesel and turbo diesel engines).

20A Headlight washer pump.

25A Front power windows.

25A Rear power windows.

10A Antilock braking system.

7.5A Low beam headlight dimming system (for countries where headlights always need to be on.)

30A Radiator fan (diesel versions).

40A Radiator fan (turbo diesel versions with heater).

60A Radiator fan (turbo diesel versions with air conditioning).

The arrangement of the fuses on the auxiliary panel varies with the number and type of devices present.

The **amperage** is clearly marked on each fuse. ALWAYS replace a blown fuse with one of the correct amperage. NEVER 'fix' a fault by using a fuse of a higher amperage, nor 'bridge' a blown fuse - it could cause a fire!

7f. When a fuse is 'blown' its conductor wire (A) has a gap in it.

If a fuse blows, find out why and put it right before fitting a new fuse.

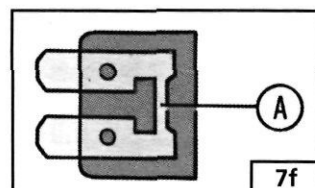

7g. TEMPRAS WITH AIR CONDITIONING

30A The Air conditioning system fuse is housed on a bracket on the engine compartment bulkhead.

The following two fuses are located under the front crossmember near the right headlight.

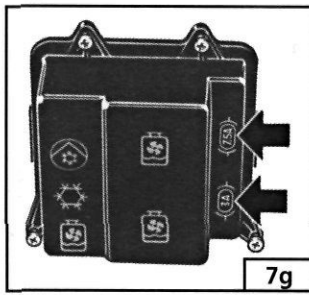

7g

3A High-speed radiator fan relay.

75A Electromagnetic air conditioner compressor clutch.

The relays housed near the fuses are part of the air conditioner circuit.

IMPORTANT NOTE: Replace the sealed cover carefully after changing a fuse. Ensure the gasket is correctly positioned and the screws are fully tightened.

7h. CERTAIN TIPO MODELS: Other fuses are i) a set of three fuses (15A, 30A and 40A) protecting the air conditioning, when fitted, located in the engine bay, near the horns (A). Press in the two sides (arrowed) to remove the cover.



And ii) there is a 60A fuse, located near the fuse box, protecting the fan on Diesel vehicles.

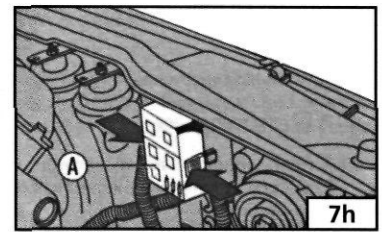

7h

7i. On latest vehicles, there are two 10A fuses (a) protecting the electric petrol pump and the Lambda sensor preheater. Remove the screws (arrowed) and the cover.

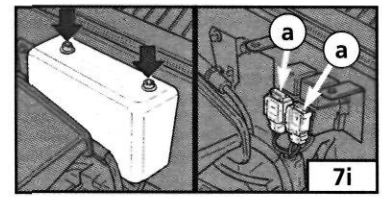

7i

PART B: ENGINE AND COOLING SYSTEM

U Job 8. Change engine oil and filter.

SAFETY FIRST!

- Refer to the section on ENGINE OILS and RAISING THE CAR SAFELY in Chapter 1, Safety First! before carrying out this work.
 - You must wear plastic gloves when changing the oil. Used engine oil can severely irritate the skin and is carcinogenic. Used diesel engine oil is an even greater health hazard.
 - Oil drain plugs are often over-tightened, so take care that the spanner does not slip.
- Take care that the effort needed to undo the drain plug doesn't tip the car off its supports - remember to use wheelchocks!

8B. Once the initial tightness of the plug has been released, unscrew the last few turns by hand, holding the plug in place until the threads have cleared, then withdrawing it smartly to allow oil to flow into the receptacle beneath.



8B

Q INSIDE INFORMATION: On side-mounted drain holes, as the oil empties, the angle of 'spurt' will change, so be prepared to move the container. Q

making it easy!

- Only drain the oil from a warm engine - but not so hot that the oil can scald! «.
- Allow the oil to drain for at least ten minutes before replacing the sump plug.
- You can use this time by renewing the oil filter.

8A. The sump drain plug is on the under-side of the sump on petrol engines, and on the side of the sump (timing belt end of engine) on the diesel. The plug has a recessed hexagonal head and you will need either a sump plug spanner, a large Allen key, or a 'Hex' headed socket fitted to a socketwrench.

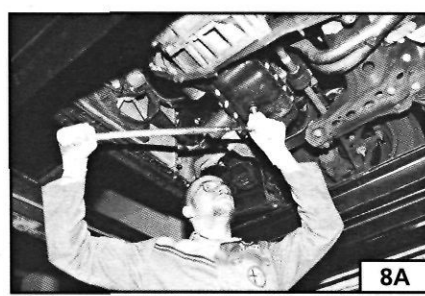

8A

IMPORTANT NOTE: The plug is a taper-fit and can become very tight, necessitating the use of a long drive-bar for its removal.

8C. On all engines, including diesel, the oil filter is mounted low on the front of the engine block, towards the timing belt. Use a strap or chain wrench to unscrew the old filter. Note that there may be a lot of oil spilt as the filter seal is broken, so keep the drip tray beneath it.

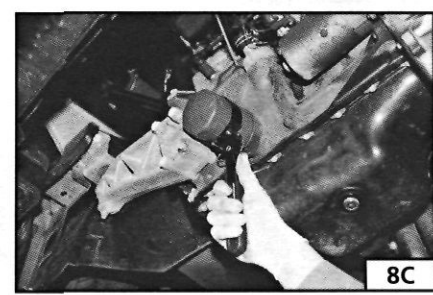

8C

8D. To prevent the rubber sealing ring on the new filter from buckling or twisting out of shape while tightening, smear it with clean oil.



8D

8E. Screw the new filter onto the stub by hand. When the rubber sealing ring contacts its seat, continue to turn the filter a further 3/4 of a turn, *by hand only*. Over-tightening the filter makes it difficult to remove at the next oil change and can buckle the seal, causing a leak.

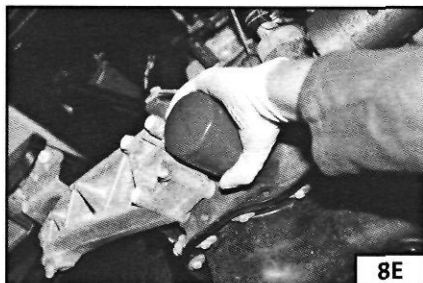

8E

Q **INSIDE INFORMATION:** It isn't necessary to use excessive force when refitting the sump plug. Simply grip the spanner (no need for an extension, now!) so that the thumb rests on the spanner head, limiting the amount of leverage that can be applied. Use firm pressure only. Before refitting the plug, wipe around the drain hole with a piece of clean cloth to remove any dirt. **Q**

8F. Pour in the correct quantity of **Selenia** engine oil (see *Chapter 3, Facts and Figures*) and check the level against the dipstick.

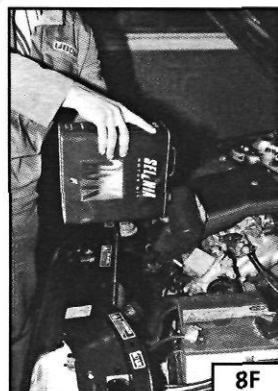

8F

Note that the empty oil filter will cause the level to drop slightly when the engine is started and the oil flows into it. Before using the car, run the engine for two minutes, turn off, leave to stand for a few minutes and then recheck and correct the oil level.

LJ Job 9. Check crankcase ventilation.

9. Check the condition of the breather hose from the valve cover or cam cover to the air cleaner. If the pipe has become blocked or damaged, replace it, transferring the flame trap from inside the old pipe to the new one. On some models, you will have to remove the air filter housing to get at the crankcase ventilation pipe beneath. Note this type of spring clip - use pliers to slacken-off when removing or refitting.



9

d Job 10. Check/adjust valve clearances.

The valve gear clearances need to be checked at the appropriate intervals, when the engine is cold.

ALL PETROL AND DIESEL ENGINES

10A. Remove the air cleaner (where necessary) - see **Job 30** then remove the bolts holding the camshaft cover in place. This is the petrol engine with air filter removed...



10A

10B. **H** **INSIDE INFORMATION:** If the gasket sticks - which it frequently does - **DON'T** lever the cover or your could or you could easily damage it.

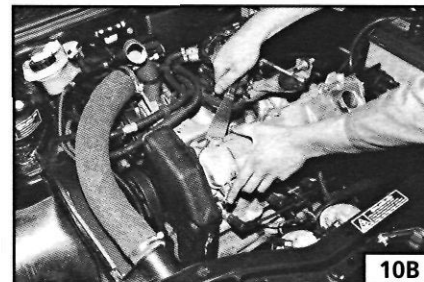

10B

Use a spatula to push through the soft joint until the gasket/cover comes free. **Q**

10C. **Q** **INSIDE INFORMATION:** The oil level inside the housing is above the level of the bottom of the cover plate on these engines. Try: i) raising the front of the car as

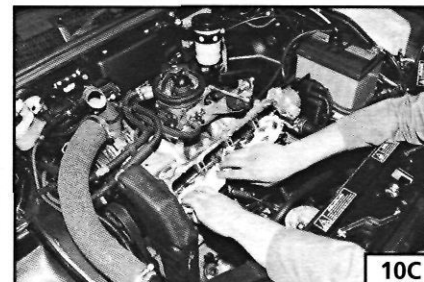

10C

high as safely possible, so that oil drains out of the back of the housing; ii) stuffing cloths beneath the opening and have more ready, for mopping up; iii) being ready to clean off the front of the engine with degreaser, when the job is finished. **Q**

10D. The valve clearance is measured directly beneath the cam and must be checked when the high point of the cam (arrowed) is pointing directly upwards and away from the cam follower.

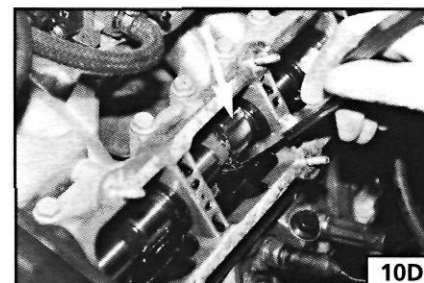

10D

Try different feeler gauge thicknesses until you find one that's a tight sliding fit between cam and follower. Make a written note of each clearance starting with number 1 at the timing belt end of the engine.

FACT FILE: VALVE IDENTIFICATION:

Remember that clearances for inlet and exhaust valves differ. See *Chapter 3, Facts and Figures*. Counting from the timing belt end the valves are:

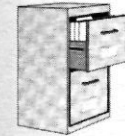

1.1,1.2 8-valve AND DIESEL ENGINES:

EXHAUST - 1, 3, 6, 8. INLET - 2, 4, 5, 7.

1372cc AND 1581cc ENGINES: EXHAUST - 1, 4, 5, 8. INLET - 2, 3, 6, 7.

1.2 16-valve Hydraulic tappets - non-adjustable.

If a clearance is outside the tolerances shown in *Chapter 3, Facts and Figures*, the relevant shim will have to be changed. New shims are available from your FIAT dealer. This work is fully described in *Chapter 6, Repairs and Replacements*.

10E. You must always use a new gasket, especially in view of the oil level mentioned earlier. Clean the housing and cover faces and use the gasket dry.

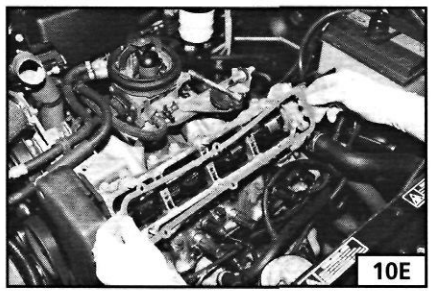

10F.D INSIDE INFORMATION: The cover is 'anti-crush'-you CAN'T tighten beyond the lugs pointed out here - so there's no point trying! **Q**

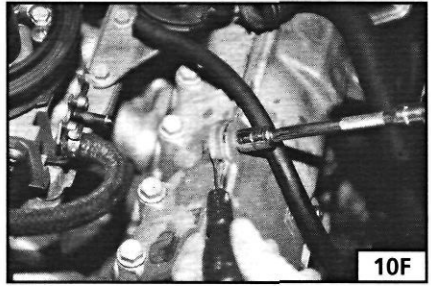

Job 11. Check camshaft timing belt.

Remove the camshaft belt outer cover. See *Chapter 6, Repairs and Replacements, PART A: ENGINE*.

11. Examine the belt for wear. If there is any cracking, or if the toothed side appears worn, or any 'teeth' are missing, replace the belt straight away. If the belt

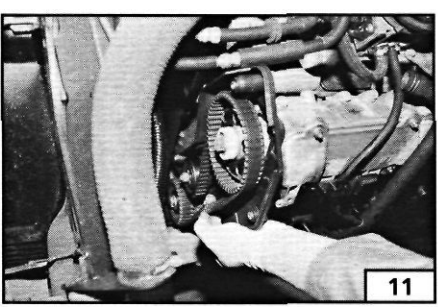

breaks the valves may collide with the pistons, causing serious engine damage. Camshaft belt replacement is described in *Chapter 6, Repairs and Replacements*, or you may wish to have your FIAT dealer carry out the work for you. If you can twist the belt through more than 90 degrees, it needs re-tensioning. Also see *Chapter 6, Repairs and Replacements*.

LJ Job 12. Change camshaft timing belt.

It is **ESSENTIAL** that you renew the camshaft drive belt at the recommended interval. See the *Service Interval Chart* at the start of this chapter *Chapter 6, Repairs and Replacements* explains how to carry out the work.

CJ Job 13. Check cooling system.

SAFETY FIRST!

- The coolant level should be checked - and the "pooling system worked on, ONLY WHEN THE ANTIFREEZANT IS COLD. If you remove the pressure cap or bleed screws when the engine is hot, scalding coolant will spurt out.
- Keep anti-freeze away from children. If it is accidentally swallowed or contacts skin or eyes, rinse immediately with plenty of water and seek immediate medical help. [-W-M^-il

Examine the cooling system hoses, looking for signs of splitting, chafing and perishing. Squeeze the top and bottom radiator hoses. Any hard, brittle areas or crackling sounds tell you that the hoses are decomposing from the inside - replacements needed!

13. If original FIAT hose clips (a) are fitted, cut them off (taking great care not to damage the stub beneath!) and replace with screw-tight clips, when fitting a new hose. Ensure that hose clips are secure and firm but not over-tightened.

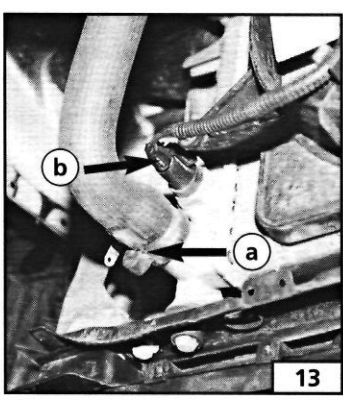

Check that the wires to the cooling fan switch (b) are in good shape. Also, refer to *Job 27*.

Job 14. Change engine coolant.

SAFETY FIRST!

- See SAFETY FIRST at the Start of Job 13.

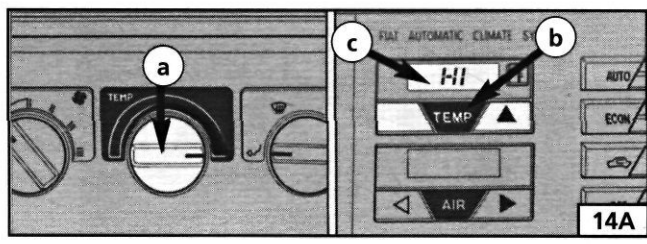

14A. Remove the expansion tank filler cap. Move the heater control (a) to the red (open) position or, on automatic systems, press the TEMP button (b) on the dash until HI appears on the display (c).

14B. Loosen the worm-drive clip (arrowed) and pull off the bottom radiator hose.

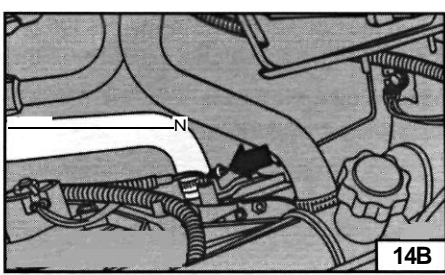

14C. Also open the drain plug or tap (B) at the centre of the rear flank of the engine block on both petrol and diesel engines. Drain the coolant into a container. On models with a separate expansion tank, detach the hose from the expansion tank and drain the tank.

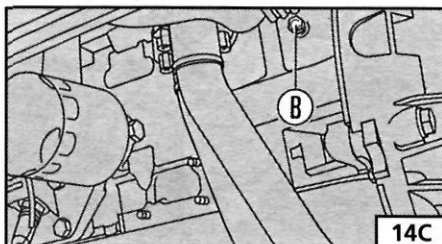

Q INSIDE INFORMATION: From time to time it's a good idea to flush the cooling system. With the bottom hose re-connected, disconnect and remove the top hose from the radiator. Insert the end of a garden hose first into the hose (packing the gap with a rag) and then the radiator inlet, flushing the system in both directions until the water comes out clear. Q

IMPORTANT NOTE: Flush first with the heater control turned OFF until the engine and radiator are clear, so that you don't flush sediment into the heater. Then with the heater turned ON, flush the heater system out.

14D. To prevent air-locks forming in the cooling system as it is refilled (all hoses and the drain plug reconnected, of course!), most models have two air-bleed screws strategically positioned in the system. These should be opened before refilling. The first (B or C) is located on the right-hand side of the radiator (type dependant on version)...

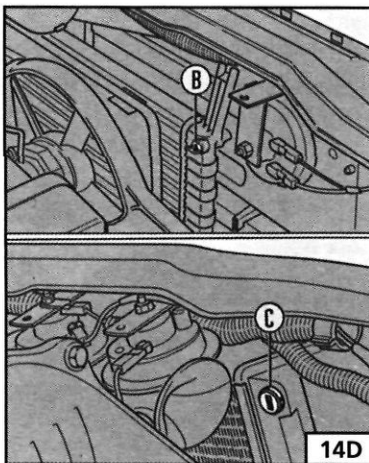

14E. ... and the second (D) - when fitted - is found on the heater hose near the top of the engine. Only undo the screws by two or three turns. Retighten both screws when air-free coolant emerges. This is the petrol engine...

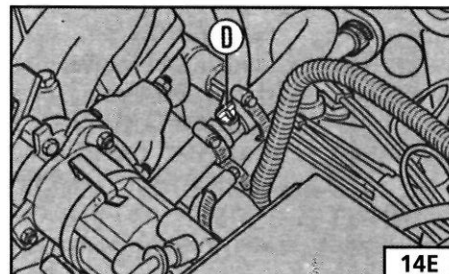

14F. ...and this the diesel engine location.

Q INSIDE INFORMATION: It seems that latest Tipos and Tempras were built without some or all bleed screws. Ryauto recommend removing the highest point of the top hose, refilling with coolant, while an assistant refits the hose smartly, losing as little coolant as possible. Q

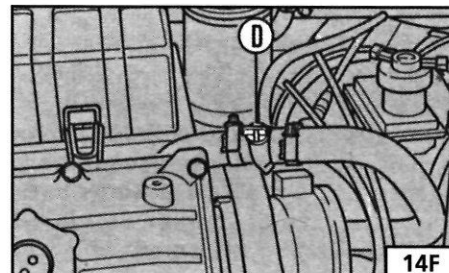

Refill the cooling system with a 50/50 mixture of clean water and fresh Paraflu anti-freeze. Tighten the bleed screws (or hose) when coolant, and not air, comes out steadily. Run the engine for a few minutes and bleed again.

IMPORTANT NOTE: It is highly likely that more air will be dislodged when you first use the car. Keep your eye on the coolant level (See **Job 2**) - perhaps carrying some 50/50 diluted coolant with you for the first few journeys.

PART C: TRANSMISSION

Q Job 15. Check manual gearbox oil level.

The combined oil level and filler plug is on the forward-facing side of the gearbox. Check the level with the car on level ground.

15. From beneath the car, wipe around the filler plug with a rag to prevent dirt contamination. Remove the plug - using a 10 mm Allen key - and top-up if necessary, using the specified Tutela transmission oil (see *Chapter 3, Facts and Figures*), until oil just dribbles from the filler hole. Refit the plug.



Q Job 16. Change manual gearbox oil.

16. The combined gearbox and final drive oil should be drained at the time shown in the *Service Interval Chart*. Do so only after the car has been used and the gearbox oil is warm, so that it flows well. Remove the drain plug (on the end-face of the gearbox, accessed from beneath the car - not much room to get a spanner in!) and drain the oil into a container. (See page 8 on oil disposal.) Leave for 10 minutes to drain completely, and refill with the correct grade of Tutela transmission oil through the level/filler plug, as described in *Job 15*.

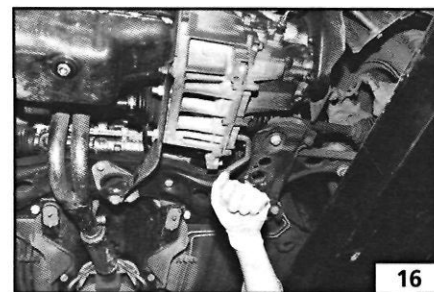

Q INSIDE INFORMATION: Make sure you have a 10 mm Allen key that will fit, before you start. There's very little room between gearbox and subframe. **Q**

Q Job 17. Check auto, transmission fluid level.

The automatic transmission fluid level should be checked with the car on level ground and the engine at normal running temperature - the car should have been driven for about 4 miles. The level is checked by means of a dipstick next to the battery.

IMPORTANT NOTE: i) It is especially important that the fluid is at the correct level. If the system needs regular topping up because of leaks, fix them as rapidly as possible or have your FIAT dealer check the system, ii) Wipe the dipstick only with a lint-free rag to avoid clogging up transmission valves. Keep dirt out!

17. Check the level with the engine idling and the gear selector in the 'P' (PARK) position. Pull out the dipstick (A), wipe it clean with paper kitchen towel, re-insert it and check the level. The upper and lower marks on the dipstick represent minimum and maximum acceptable fluid levels.

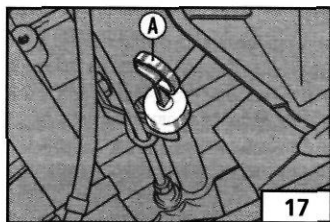

17

If necessary, fresh **Tutela CVT** should be poured in through the dipstick tube, using a funnel in the tube or by using ATF from a dispenser with a small spout. You may have to leave the fresh oil to clear the tube before seeing a clear dipstick reading.

Q Job 18. Replace auto, transmission fluid and filter.

As well as **Tutela CVT** fluid, you will need a new, sump gasket and a new gearbox oil filter, from your FIAT dealer. The filter should be changed every time the oil is replaced.

18A. Always drain the fluid when the transmission is warm, such as after a run. Raise the front of the car on ramps, so the fluid drains well from the drain hole (C) at the rear underside of the 'box.

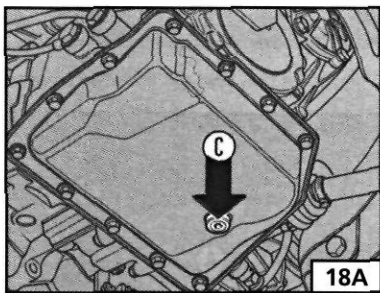

18A

Remove the drain plug with an Allen key or hexagonal socket adaptor, and allow the fluid to drain into a container beneath the transmission - allow ten minutes for complete drainage.

Undneath the car, remove the 13 transmission sump bolts.

D INSIDE INFORMATION: The sump is easily distorted, so, when refitting, tighten all bolts progressively and evenly to the recommended torque -see **Chapter 3, facts and Figures. Q**

18B. The filter is secured by one central screw. Undo this and pull the filter down, detaching its upper fluid pipe in the process. Remove the filter, discard it and fit the replacement. Refit the sump, using a new gasket and non-setting gasket sealer.

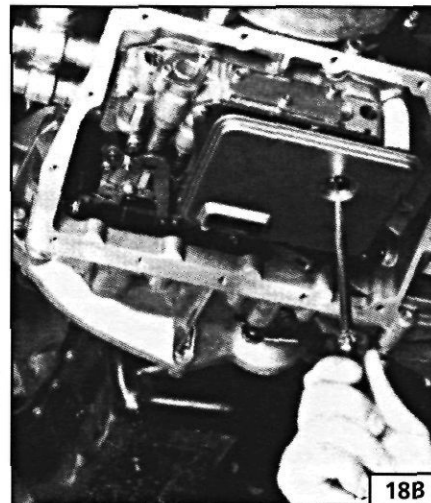

18B

Replace the drain plug and fill the gearbox through the dipstick tube. (See Job 17.)

IMPORTANT NOTE: Take care not to allow any dirt or grit to get into the gearbox.

U Job 19. Check driveshaft gaiters.

19A. Grasp and turn the inner drive-shaft and gaiters, checking for signs of gaiter splitting or damage that could allow grease out or - worse still - water in. Ensure the gaiter clips are secure.



19A

Q INSIDE INFORMATION: Inners tend to leak, putting an oil stain on the shaft, as here. You can buy a FIAT repair kit, with bearing and replacement gaiter, to repair the leak. This involves removing the drive shaft- see **Chapter 6, Repairs and Replacements. Q**

19B. Check the outer gaiter as well. This moves over a greater range and is more prone to damage and splits.

IMPORTANT NOTE: Change a split, or damaged gaiter as soon as possible - preferably before using the car again.

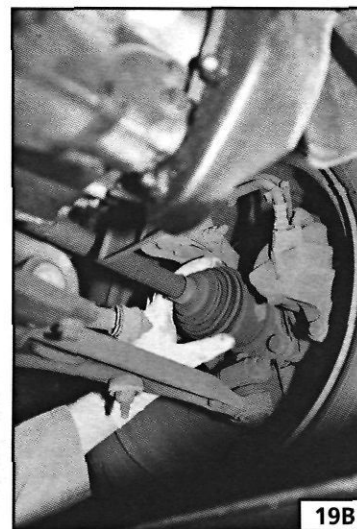

19B

- Job 20. Check/adjust clutch.



FACT FILE: CABLE OR HYDRAULIC CLUTCH?

- Most earlier Tipos and Tempras had a cable-operated clutch, while later ones are hydraulic.

• 20A. You can easily tell which system your car is fitted with. The hydraulic pipe (if fitted) runs almost horizontally, across the back of the engine bay.

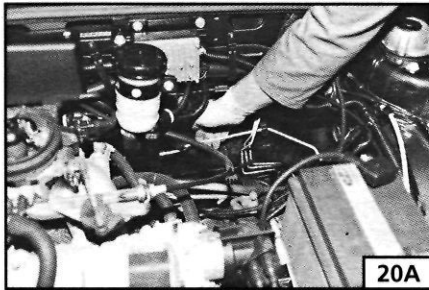

- There is no separate clutch fluid reservoir - it shares the brake fluid reservoir.
- Clutch cables (when fitted) are inclined to break without warning.
- It pays to keep the operating mechanism well lubricated and renew the cable every few years.

HYDRAULIC CLUTCH

20B. Check the pipework and slave cylinder, on the gearbox casing, from beneath the car. If the pipe appears cracked, replace it. If the slave cylinder oozes fluid, replace it, in both cases bleeding the system. See *Chapter 6, Repairs and Replacements*.

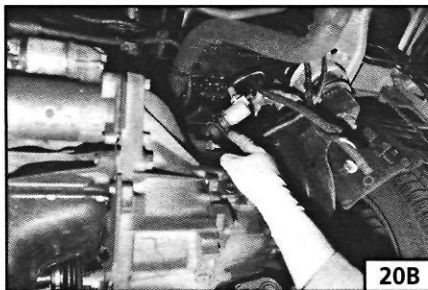

CABLE OPERATED CLUTCH

The clutch mechanism is self-adjusting, although the cable linkage can stretch over a period of time and may need adjustment. The adjuster is on top of the gearbox, reached from inside the engine bay.

20C. 'Work' the clutch pedal (X) a few times, pull back the carpet from under the pedal, then measure the full travel of the pedal, which should be between 140 and 150 mm.

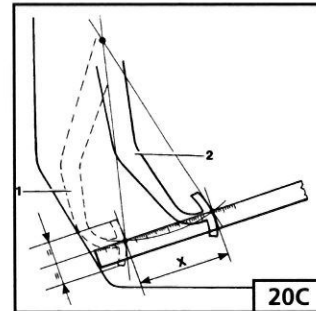

20D. If not, note that after slackening the locknut, turning the adjusting nut inwards (arrowed) will increase pedal travel. Tighten the lock-nut against the inner nut after adjustment.

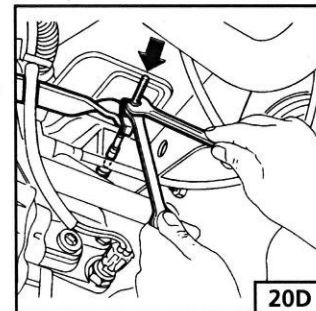

Q Job 21. Check auto, transmission selector cable.

It should only be possible to start the engine when the gear selector is in the 'P' or 'N' position. Place it in each of the other positions and try to start the car. If it starts, the fault must be put right! Also check that, with the ignition off and the selector lever in 'D' (Drive), 1' (Low), 'R' (Reverse) or 'N' (Neutral), the timed warning buzzer should sound. If it doesn't, the selector cable adjustment may be faulty.

See *Chapter 6, Repairs and Replacements, PART B: TRANSMISSION AND CLUTCH, Job 8* for adjustment details.

PART D: IGNITION AND ELECTRICS

See *FACTFILE: DISCONNECTING THE BATTERY* on page 36

SAFETY FIRST!

- You may minimise the risk of shock when the engine is running by wearing thick rubber gloves and by NEVER working on the system in damp weather or when standing on damp ground. Read *Chapter 1, Safety First!* before carrying out any work on the ignition system.
 - **ELECTRONIC IGNITION SYSTEMS INVOLVE VERY HIGH VOLTAGES!** All manufacturers recommend that only trained personnel should go near the high-tension circuit (coil, distributor and HT wiring) and it is **ESSENTIAL** that anyone wearing a medical pacemaker device does not go near the ignition system.
 - Stroboscopic timing requires the engine to be running - take great care that parts of the timing light or parts of you don't get caught up in moving components!
- ^m Don't have loose clothing or hair.

EJ Job 22. Check/clean/gap spark plugs.

GENERAL On all Tipo and Tempra petrol engines the spark plugs face forwards, allowing easy working access.

Carefully remove the spark plug caps, being careful to pull only on the cap and not the HT lead. If you can't be sure to remember which HT lead belongs to which spark plug, number them from one end of the engine to the other.

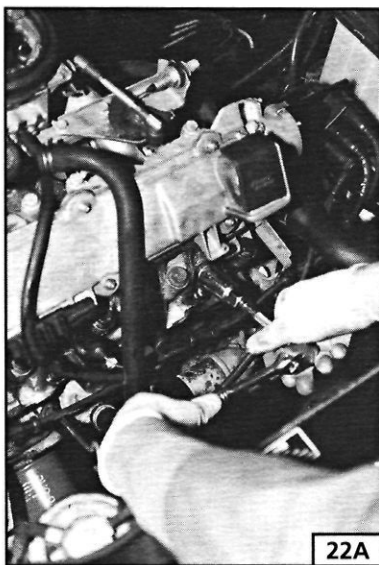

22A. Unscrew the plug using the correct type of spark plug socket. Take care to keep the spanner strictly in line with the plug so as not to crack the electrode.

22B. If the electrodes of the plugs look rounded and worn, replace the plugs. See page 154 for details of 'Reading Your Spark Plugs'. 'Nip' the cap tight with pliers, so that it can't come loose.



22C. It is essential that the plug is gapped correctly. See *Chapter 3, Facts and Figures*. Use a feeler blade of the correct thickness, sliding it between the electrodes. It should be a firm sliding fit. Use a gapping tool or carefully wielded pliers to bend the curved electrode towards or away from the centre electrode. Take **GREAT CARE** not to damage the insulator near the tip of the plug.

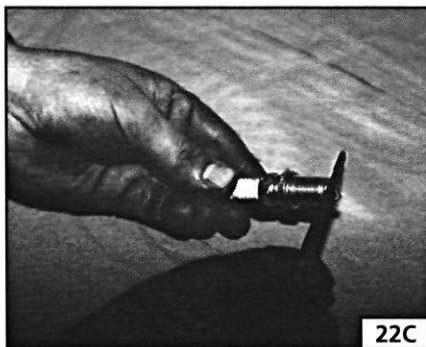

D INSIDE INFORMATION: The spark plugs screw into aluminium, which is easily damaged if the spark plugs do not engage their threads properly. Screw in the plugs by hand initially - by, say, two or three turns - before using the plug spanner. A light smear of copper grease on the plug threads will enable them to turn more freely and also make them easier to remove next time. Finally, don't over-tighten the plugs - firm hand-pressure on the spanner is sufficient. **Q**

• Job 23. Change spark plugs.

Spark plugs 'tire' and lose efficiency over a period of time, even if they look okay. See *Job 22* for information on their removal and replacement. Use good quality Champion or FIAT plugs of the correct specification.

□ J Job 24. Check/clean HT leads and distributor cap.

SAFETY FIRST!

See **SAFETY FIRST!** at the start of this section and **Chapter 1, Safety First!**

IMPORTANT NOTE: On latest models, there is no conventional distributor and, for those cars, none of the following should be attempted. Illustration to **Job 28C** illustrates the type which should NOT be worked on except for wiping off the outer surface, with the engine not running.

Remove each plug lead from the spark plugs, pulling only on the plug caps, not on the HT cables. Also, remove the large HT lead from the coil and take off the distributor cap, either by popping off its spring retainers if the distributor is on the side of the engine (front of engine bay - see illustration **25A**) or by undoing the two retaining screws.

24A. On later cars (Digiplex ignition - distributor mounted horizontally on end of cylinder head) unclip and remove the shroud. Clean the cap and cables of either type with a clean rag, applying a little aerosol water-dispellant spray to help shift oil and grime.



24B. Check each of the HT posts (a) inside the cap for burning or damage, and the central carbon brush (b) to ensure that it's not worn down and that the spring loading is okay. Clean the dust cover (c) and rotor arm, and check the tip (d) for burning.

IMPORTANT NOTE: DO NOT spray water dispellant or apply lubricant to any part of an electronic ignition distributor. (It's okay to clean the cap, as described, however.)

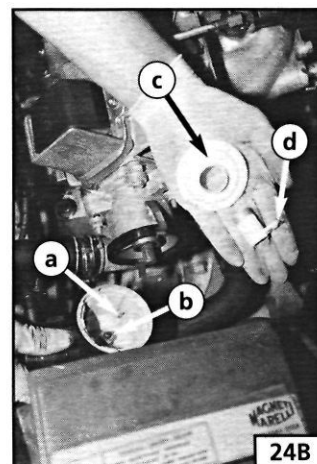

LJ Job 25. Check ignition timing.



FACT FILE: IGNITION SYSTEM TYPES

Two different types of electronic ignition systems have been fitted to the petrol engines covered by this manual.

The earlier Breakerless Inductive Discharge System can be adjusted. Its distributor is fitted as shown in illustration 25A.

The later, Digiplex 2 system, has an integrated ignition and fuel injection control system and any checks and adjustments will need to be carried out by your FIAT dealership with the appropriate diagnostic equipment. See Job 28.

MAGNETI MARELLI BREAKERLESS INDUCTIVE DISCHARGE IGNITION SYSTEM

CHECK VACUUM AND MECHANICAL ADVANCE SYSTEMS

25A. This is the location of the breakerless electronic ignition components in the car. The distributor (1) is fitted to the front of the block while the ignition coil (2) is alongside the battery.

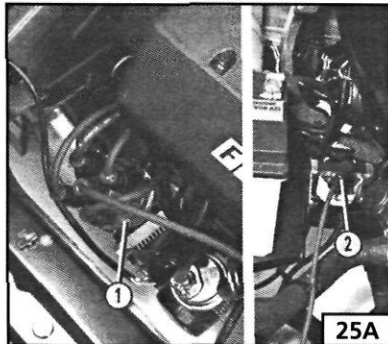

25B. This type of distributor can be identified by the electronic ignition control module (a) and the vacuum advance unit (b), not fitted to other ignition types.

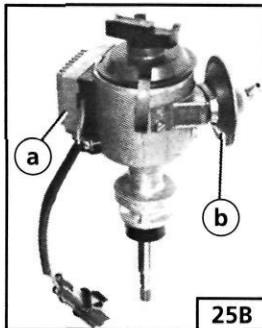

IMPORTANT NOTE: Before checking the ignition timing, you must be certain that:

- the pipe from the distributor vacuum unit is disconnected from the distributor and plugged.
- the engine must be at its normal operating temperature.
- the idle speed/mixture/CO adjustments must be correct - see Job 35.

25C. To check the ignition timing, connect up a stroboscopic lamp, either as shown on the inset or in accordance with the manufacturer's instructions. The timing light should always be connected to No. 1 spark plug lead - the one nearest the timing belt end of the engine.

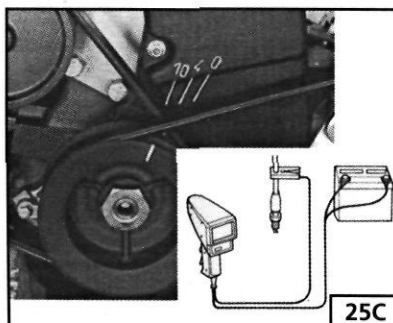

- Start the engine and run it at between 750 and 850 rpm.
- Point the timing light at the crankshaft pulley timing mark and ensure that the mark lines up with the 10 degrees Before Top Dead Centre (BTDC) mark on the timing belt cover.
- If the reading is 'out' stop the engine and slacken the clamp nut on the distributor so that the distributor can just be turned with firm hand pressure.
- Turn the distributor a very small amount, restart the engine and check again.
- Repeat the procedure until, with the engine running, the crankshaft pulley timing mark lines up with the 10 degree BTDC mark. Then tighten the nut securing the distributor to the engine block.

You can now check the vacuum advance system as follows;

- increase the engine speed to approximately 2,000 rpm and, with the timing light pointed at the timing marks, make a mental note of the position of the mark on the crankshaft pulley in relation to the timing belt cover. If the position is no further advanced than 10 degrees BTDC, the mechanical advance system inside the distributor is probably seized.
- stop the engine, reconnect the vacuum advance pipe and repeat the procedure.
- you should see a further amount of advance taking place and if not, the diaphragm inside the vacuum advance mechanism is probably punctured.
- if either or both of these faults have occurred, your engine will run uneconomically and inefficiently and it may pay you to fit a new distributor.

MAGNETI MARELLI DIGIPLEX 2 ELECTRONIC IGNITION

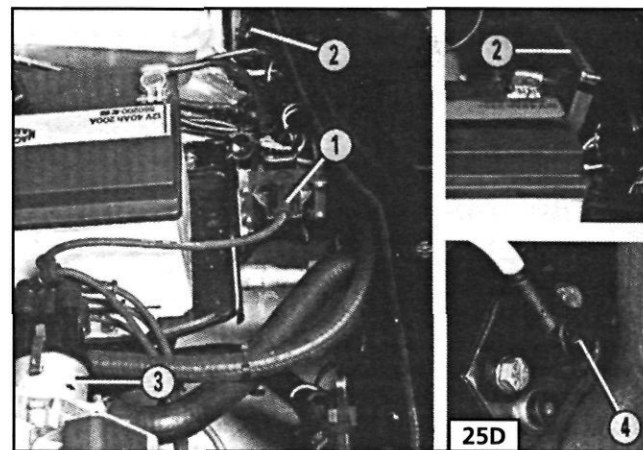

25D. This is the layout of the Digiplex ignition system, viewed from over the engine looking towards the left-side of the car. The ignition coil (1) is adjacent to the battery. The electronic control unit (2) is nearer to the engine bay sidewall. The distributor (3) is mounted on the end of the cylinder head and the rpm and Top Dead Centre (TDC) sensor (4) is located on the crankshaft cover on the flywheel side.

FACT FILE: DIGIPLEX DISTRIBUTOR REMOVAL

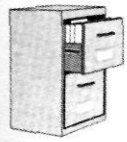

25E. If the distributor has to be removed for any reason, it is **ESSENTIAL** that the **PRECISE** position of the rotor arm in relation to the distributor body and the

position of the distributor body (2) in relation to the cylinder head - via the spacer (1) - are clearly marked so that they can be

replaced in **EXACTLY** the same position. Note that the locator (arrowed) only gives an approximate, not a precisely correct location of the spacer.

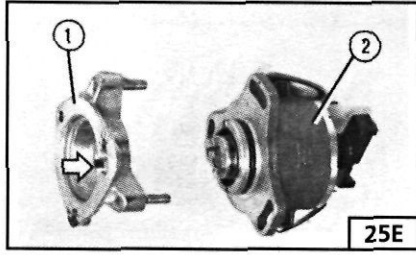

25F. H INSIDE INFORMATION:

Use touch-up paint and let it dry before removing the unit. H

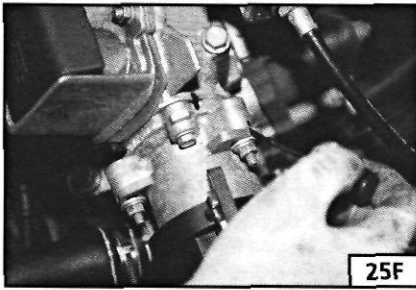

IMPORTANT NOTE: The slots in the distributor body are **NOT** used to alter the advance setting, as on a conventional distributor. This operation is carried out by the position of the TDC sensor - see later.

CHECKING THE IGNITION ADVANCE can be carried out in an approximate manner using the same method as described in **25C**. However, you must make sure that the following steps are taken:

- the vacuum pipe between the electronic control unit and the inlet manifold must remain connected and be in good condition - neither blocked nor split.
- the engine must be at its normal operating temperature.
- the idle speed/mixture/CO adjustments must be correct - see Job 35.
- with the engine idling at between 800 and 900 rpm, the mark on the crankshaft pulley should be at approximately 12 degrees BTDC.

IMPORTANT NOTE: The only marks are for 0, 4 and 10 degrees BTDC, so you will have to make a guess at the correct position for 12 degrees.

FACT FILE: TIMING MARKS

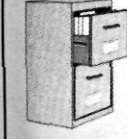

It appears that some earlier engines may be fitted with different types of timing marks. There might be a metal pointer fitted to the timing belt cover.

Other engines may have their timing marks in the flywheel housing, so that you need to take out a rectangular rubber bung and look out for the fixed timing mark on the flywheel housing and the timing settings on the flywheel itself.

- It always helps to paint all of the timing marks with white paint or typists' correction fluid so that they are easier to see when the timing light is operating.

SETTING THE RPM AND TDC SENSOR POSITION

25G. This job can not be carried out without the **FIAT** special tool illustrated. The sensor is correctly positioned when the engine is produced and to prevent accidental tampering, one of the two bolts holding the sensor in place is a shear bolt and will have to be renewed if removed.

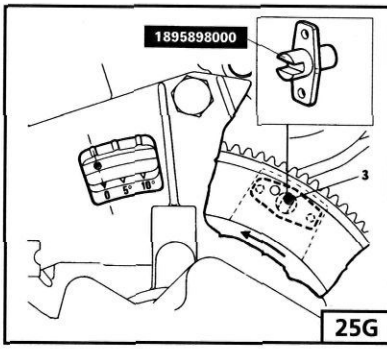

1. Line up the mark on the crankshaft pulley with the 0 degrees (TDC) mark on the timing belt cover. See **25C**.
2. Without moving the crankshaft from this position, undo the screws holding the rpm and TDC sensor to the sensor carrier plate. Fit the tool no. 1895898000 in place of the sensor. Check that the flywheel pin or lug (3) must fit in the groove of the tool and the bolts must tighten easily. If not, carry out the following procedure:
3. Slacken the bolts securing the carrier plate behind the sensor.
4. Move the plate so that the tool slips freely into the sensor's hole and the bolts tighten easily.
5. Tighten the bolts holding the sensor carrier plate in place.
6. Remove the tool and refit the sensor.

OU BOTH TYPES: As the distributor is turned (clockwise to advance, anti-clockwise to retard), the timing mark on the flywheel will be seen to move relative to the pointers. Move the distributor so the timing marks are aligned correctly, and retighten the clamp nut or bolts.

Job 26. Check/adjust drive belt/s.

26A. Depending on your Tipo or Tempira model, access to the alternator belt and adjustment fixings will probably be possible from the engine bay.

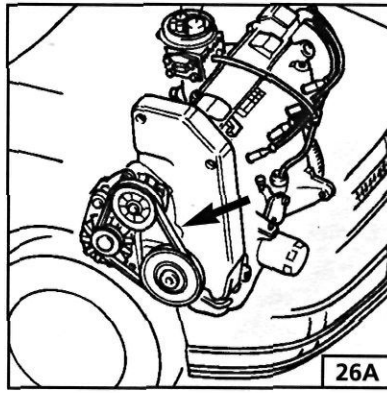

V-BELTS ONLY

Check the belt, and if there is any sign of cracking, 'polishing', fraying or severe wear on the inner face, replace it. The belt should deflect by about 10 mm when firm thumb pressure is applied to the belt between the pulleys in the direction of the arrow. Too little tension and the belt might slip; too much, and belt and bearing wear will increase.

Running The Vehicle

NEVER start the engine unless the gearbox is in neutral (or 'Park' in the case of automatic transmission) and the hand brake is fully applied.

NEVER run catalytic converter equipped vehicles without the exhaust system heat shields in place.

TAKE CARE when parking vehicles fitted with catalytic converters. The 'cat' reaches extremely high temperatures and any combustible materials under the car, such as long dry grass, could be ignited.

Personal Safety

NEVER siphon fuel, antifreeze, brake fluid or other such toxic liquids by mouth, or allow contact with your skin. Use a suitable hand pump and wear gloves.

BEFORE undertaking dirty jobs, use a barrier cream on your hands as a protection against infection. Preferably, wear suitable gloves, available from DIY outlets.

WEAR IMPERVIOUS GLOVES for sure when there is a risk of used engine oil coming into contact with your skin. It can cause cancer.

WIPE UP any spilt oil, grease or water off the floor immediately.

MAKE SURE that spanners and all other tools are the right size for the job and are not likely to slip. Never try to 'double-up' spanners to gain more leverage.

SEEK HELP if you need to lift something heavy which may be beyond your capability. Don't forget that when lifting a heavy weight, you should keep your back straight and bend your knees to avoid injuring your back.

NEVER take risky short-cuts or rush to finish a job. Plan ahead and allow plenty of time.

BE METICULOUS and keep the work area tidy - you'll avoid frustration, work better and lose less.

KEEP children and animals right-away from the work area and from unattended vehicles.

ALWAYS tell someone what you're doing and have them regularly check that all is well, especially when working alone on, or under, the vehicle.

HAZARDS

Fire!

Petrol (gasoline) is a dangerous and highly flammable liquid requiring special precautions. When working on the fuel system, disconnect the vehicle battery earth (ground) terminal whenever possible and always work outside, or in a very well ventilated area. Any form of spark, such as that caused by an electrical fault, by two metal surfaces striking against each other, by a central heating boiler in the garage 'firing up', or

even by static electricity built up in your clothing can, in a confined space, ignite petrol vapour causing an explosion. Take great care not to spill petrol on to the engine or exhaust system, never allow any naked flame anywhere near the work area and, above all, don't smoke.



Invest in a workshop-sized fire extinguisher. Choose the carbon dioxide type or preferably, dry powder but NEVER a water type extinguisher for workshop use.

DONT disconnect any fuel pipes on a fuel injected engine without following the advice in this manual. The fuel in the line is under very high pressure - sufficient to cause serious injury. Remember that many injection systems have residual pressure in the pipes for days after switching off. If necessary seek specialist advice.

Fumes

Petrol (gasoline) vapour and that given off by many solvents, thinners, and adhesives are highly toxic and under certain conditions can lead to unconsciousness or even death, if inhaled. The risks are increased if such fluids are used in a confined space so always ensure adequate ventilation. Always read the maker's instructions and follow them with care.

Never drain petrol (gasoline) or use solvents, thinners adhesives or other toxic substances in an inspection pit. It is also dangerous to park a vehicle for any length of time over an inspection pit. The fumes from even a slight fuel leak can cause an explosion when the engine is started.

26B. If adjustment is necessary, slacken the tensioning nut (A) and the alternator pivot (B), on all models. (These are two typical layouts.)

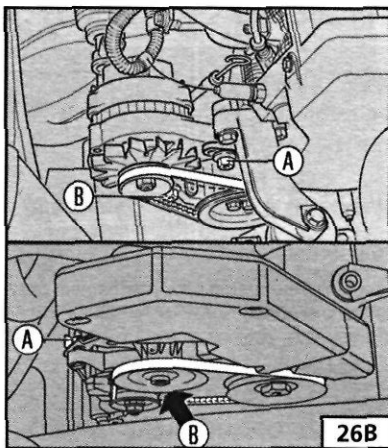

Use a length of wood to pivot the alternator away from the engine block but take great care not to damage the alternator casing. Tighten the nuts/bolts when the tension is correct.

RIBBED BELTS ONLY

If your vehicle is fitted with a ribbed belt, pivot the alternator as described above and tighten it when you can just twist the belt by 1/4 turn in the middle of its longest run.

IMPORTANT NOTE:

- Belt tension should only be adjusted when the engine is cold.
- After adjustment, run the engine for 15 to 30 seconds, to allow the belt to bed-in, then check again.
- Experience mechanics claim that belts often go slack when the engine heats up, producing belt squeal.
- If this happens on your vehicle, adjust the belt again when the engine is hot. Wear industrial leather gloves and long-sleeved overalls and take very great care not to burn yourself on the hot engine or exhaust.

If there is an auxiliary unit, such as an air conditioning pump, driven by a separate drive belt, examine and adjust it as described here.

Q Job 27. Check electric fan operation.

Drive the car until it is at normal operating temperature. Park outdoors and, with the gearbox in neutral (or 'P' in the case of an automatic) leave the engine running. At just above normal temperature the electric cooling fan should come on, and then go off again when the temperature drops. Refer to your temperature gauge, if fitted. If the fan doesn't behave, check the thermo-switch on the radiator, along with all connections and wires in its circuit with the fan motor. See *Job 13* and *Chapter 6, Repairs and Replacements*.

Q Job 28. Run diagnostic ignition/injection test.

DIAGNOSTIC TEST

28A. Have your FIAT dealer carry out a diagnostic test, plugging his tester into the diagnostic socket tucked away at the front of the passenger-side footwell.



EMISSIONS TESTS

Vehicles fitted with the Mono-Jetronic fuel injection system are not fitted with adjustment screws. The system is self-regulating. However, specified annual checks carried out with an exhaust gas analyser will provide essential information on the condition of the injection/ignition system, the catalytic converter and the engine itself.

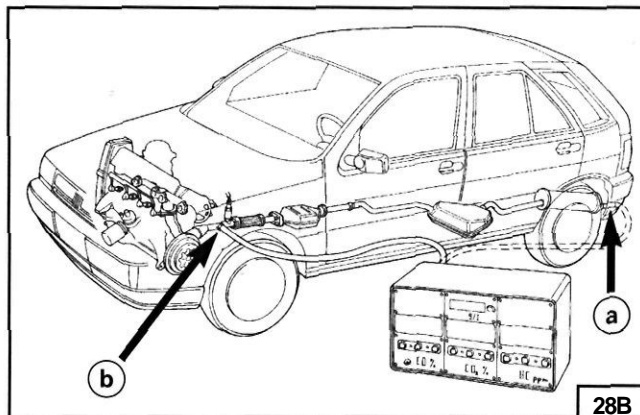

28B. The checks are carried out twice: once with the test sensor at least 300 mm into the end section of the exhaust pipe (a). (If the shape of the end section of the exhaust pipe is such that the sensor cannot be completely introduced, a special extension pipe must be added ensuring that the joint with the car's tail-pipe is sealed.); the second after undoing the cap or nut on the exhaust pipe upstream of the catalytic converter (b).

The following table shows the test limits for carbon monoxide, unburned hydrocarbons (in parts per million) and carbon dioxide:

| | CO (%) | HC(p.p.m.) | CO ₂ (%) |
|---------------------------------|---------|------------|---------------------|
| Upstream of the catalyzer (a) | 0,4 ^ 1 | « 500/600* | ≥12 |
| Downstream of the catalyzer (b) | ^ 0,35 | « 90 | ≥13 |

- FIAT's figures vary.

IMPORTANT NOTE: The engine must be at its normal operating temperature and normal tick-over speed.

- if the percentage concentration of CO upstream of the catalytic converter is not within the limits in the table, check:
 - the Lambda sensor - see *Job 37*.
 - air penetration around the Lambda sensor housing.
 - faults in the ignition or injection systems. (First try renewing the spark plugs, distributor cap and HT leads.)

If, at the same time, the concentration of hydrocarbons is not less than 500/600 parts per million (FIAT'S figures vary), check:

- the ignition timing (see *Job 25*).
- the valve clearances (see *Job 9*).
- the valve gear timing (see *Job 12*).
- the engine compression. (You will need to remove the spark plugs, fit a compression tester to each plug aperture in turn and crank the engine. See the **FACT FILE** on *page 51*.)

FACT FILE: CRANKING AN ENGINE WITH ELECTRONIC IGNITION

Severe damage can be caused to the ignition system if the engine is cranked with plugs/leads removed - and a severe electric shock can be experienced.

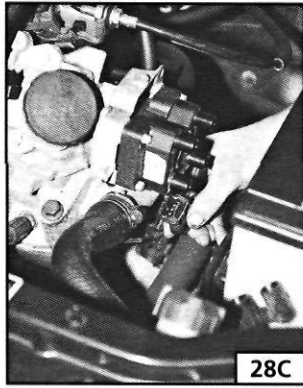

28C

28C. With very latest 'distributorless' system, disconnect the multi-plug from the base of the 'black box'.

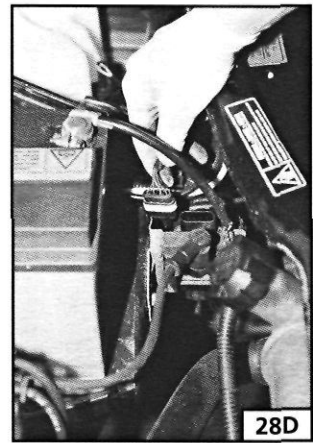

28D

28D. With the two earlier systems, disconnect the multi-plug leading to the distributor/control unit from the ignition coil behind the battery.

IMPORTANT NOTE: If the HC reading when measured at the end of the exhaust pipe is outside of the recommended limit while that measured upstream of the

catalytic converter is OK, the cat. is almost certainly faulty. Have it double-checked by your dealer before replacing it - an expensive component!

PART E: FUEL AND EXHAUST

SAFETY FIRST!

Always wear impervious gloves so that fuel cannot come in contact with your skin. It can induce cancer.

G Job 29. Check fuel pipes for leaks.

Check the fuel lines from the fuel tank and into the engine compartment, looking for signs of chafing, splits and perishing of the rubber and plastic parts. Ensure any worm-drive hose clips used on the connections are firm and secure.

J Job 30. Change petrol air filter.

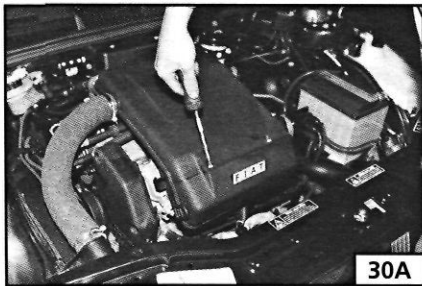

30A

30A. Unscrew the two screws (arrowed)...

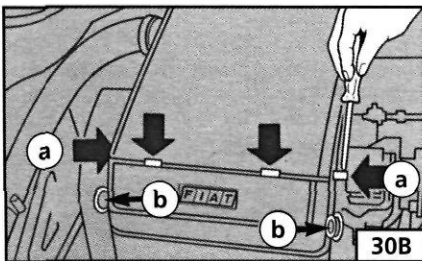

30B

30B. ...and release the two fasteners (a) and the two spring clips (b).

30C. Pull on the tabs - and watch that the springs don't fall on the floor as you release the catches!



30C

30D. Lower the filter cover and lift out the filter element.



30D

• Job 31. Change diesel air filter.

31A. Take out the four screws (arrowed) and lift off the cover (B).

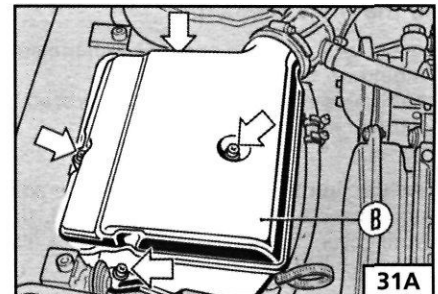

31A

31B. If you want to take the cover right off, you will have to unscrew the air hose clamp (arrowed). Remove and replace the filter element (A).

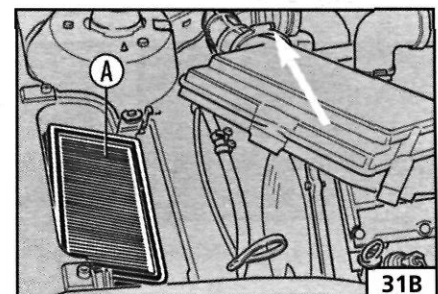

31B

Job 32. Change petrol fuel filter.

FUEL INJECTION MODELS

32A. The filter is under the car, ahead of the fuel tank.



D **INSIDE INFORMATION:** Remove the visible screws holding the flexible plastic cover in place. You can now pull the front down and out of the way. **B**

32B. Undo the clamp, remove the outer casing and renew the special paper filter, from your FIAT dealership. There is an arrow on the casing to remind you which way round it must be fitted.

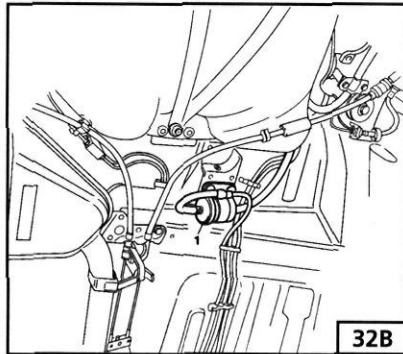

Q **INSIDE INFORMATION:** Plastic fuel pipes become brittle and snap. Extra care needed! **B**

SAFETY FIRST!

- The high pressure pipework on a fuel injection system can retain its pressure for days even after the engine has been switched off,
- When you disconnect the pipework, a jet of fuel can be emitted under very high pressure - strong enough to penetrate the skin or damage the eyes.
- NEVER work on the fuel pipework when the engine is running (except when bleeding Diesel injectors).
- ALWAYS place a rag over a union while it is being undone until all the pressure has been let out of the system.
- You are recommended to wear strong rubber gloves and goggles when disconnecting the fuel injection system's high pressure pipework. Always disconnect VERY slowly, letting pressure out progressively.
- See **Chapter 6, PART F: Job 8** for details of how to depressurise the system.
- Disconnect the battery negative earth before working on the fuel system,
- Work outdoors and away from sources of flame or ignition.
- ALWAYS wear rubber gloves - don't let your skin come into contact with fuel.

IMPORTANT NOTES:

- Wear plastic gloves and goggles and have a large rag and a suitable fire extinguisher ready.
- Place a container beneath the filter to catch fuel spillage.
- After fitting the new filter in place, refit the casing, ensure no traces of fuel are left, reconnect the battery and restart the engine.
- Check carefully to ensure there are no leaks before refitting the cover.

L1 Job 33. Drain diesel fuel filter.

IMPORTANT NOTE: Some models are fitted with a water-in-fuel sensor. Drain the filter when the warning light comes on. Unplug the sensor from the base of the filter, first.

33. The fuel filter is located in the rear of the engine compartment. Water carried in the fuel accumulates in the bottom of the filter, and should not be allowed to build up.



To drain it position a receptacle under the filter, then unscrew the knurled tap at the bottom of the filter by a couple of turns. Do so at the recommended interval, or if the panel indicator comes on. (See *Chapter 2, Getting to Know Your Car.*)

IMPORTANT NOTE: All Tipo/Tempra diesel engines are self-bleeding and there should be no need to bleed air out of the system manually.

LJ Job 34. Change diesel fuel filter.

Drain the fuel filter. Unscrew the complete filter canister from its head, in the same way that you would an engine oil filter. First unclip the sensor plug (if fitted) from the base of the unit.

making it easier

34A. If it is too tight to unscrew by hand, use an oil filter wrench on the lower.

flatted zone (C). Wipe the underside of the filter head, fill the new filter with fuel...

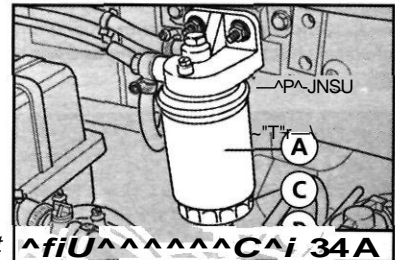

34B. ...lightly lubricate its seal with fuel, then screw it onto the filter head. Once it is 'nipped up', tighten it as far as possible by hand. without 'murdering' it - so that you CAN remove it next time!



IMPORTANT NOTE: • All Tipo/Tempra diesel engines are self-bleeding and there should be no need to bleed air out of the system manually.

• If the engine does not eventually re-start, check all the unions for the fuel inlet pipe and the other unions, replacing the sealing washers if necessary, to eliminate any air leaks.

J Job 35. Check/adjust petrol engine idle and emissions.

Setting the idle speed and mixture is not just a matter of making the car run smoothly and economically; it's also a question of allowing it to run within the legal hydrocarbon (HC), Nitrous Oxide (NO) and carbon monoxide (CO) emission limits. If it is outside limits, the car will fail the annual test. (However, a worn engine will fail even if the carburettor or injection system is correctly set up.)

FACT FILE: ESSENTIAL PREPARATIONS

• When tuning the engine you should adjust the carburettor (when fitted) last of all, as its settings will be affected by the state of tune of the rest of the engine.

- Ignition dwell angle and timing must be correct, the air filter should be clean, there should be no air leaks on the induction system, and all electrical components and the air conditioning (if fitted) should be switched off.
- Get the engine to full operating temperature before checking and adjusting.
- If you warm the engine on tick-over (instead of on a journey), it won't be hot enough until you have heard the electric cooling fan cut in twice.

Q INSIDE INFORMATION: These jobs require the use of a tachometer (rev-counter) and an exhaust gas analyser to achieve any degree of accuracy. If you don't own them - and relatively inexpensive tools are now available - you may wish to have the work carried out by your local FIAT dealer. **Q**

ROUGHGUIDE: Within each section is a description of how you can get the car running tolerably well without any specialist equipment, so that you can take it to your FIAT dealership for accurate (and MoT-able!) tuning.

CARBURETTOR MODELS ONLY

TAMPER PROOFING: All Tipo carburettors originally had a tamper-proof seal placed over the mixture adjustment screw. These seals are to prevent anyone unauthorised from altering the mixture and exhaust emissions. In certain countries these seals must be retained by law.

If the seal is a plastic cap placed over the adjuster screw, it can be broken off with pliers. If it is a plug within the screw recess, force it out with a sharp object.

35A. Check the float level with the carburettor in the position shown. Distance (c) should be 30mm with gasket fitted. Bend tab (2) to adjust - but the tab should remain virtually perpendicular. Do NOT adjust items (1) or (3)!

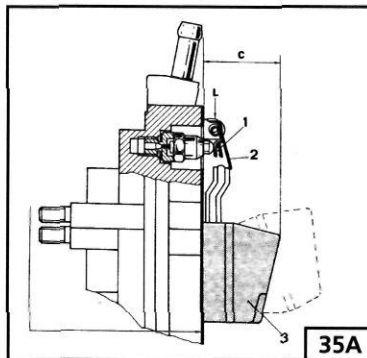

35B. IDLE SPEED ADJUSTMENT: Connect a rev-counter according to the maker's instructions, and check the idle speed. Turn (1) clockwise increases the idle speed, anti-clockwise reduces it. Set the idle speed in with **Chapter 3, Facts and Figures.**

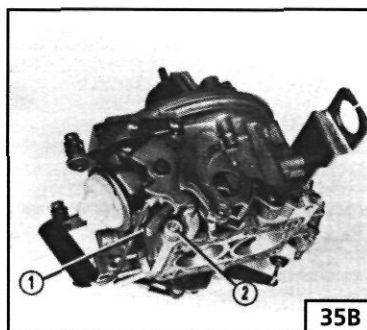

ROUGH GUIDE: Turn the screw until the engine is running at the slowest speed at which it runs smoothly and evenly.

MIXTURE ADJUSTMENT: Check that the idle speed is correct and make sure that the engine is at full operating temperature. Connect an exhaust gas analyser as instructed by the maker. If the CO reading is outside the range shown in **Chapter 3, Facts and Figures**, adjustment as follows: Use a narrow-blade screwdriver and turn the screw (2) clockwise to weaken (reduce) or anti-clockwise to richen (increase) the reading.

ROUGH GUIDE: Turn the mixture screw inwards (clockwise). As you do so, the tick-over speed will increase, until the point comes where the engine starts to run 'lumpily'. Back off the screw until the engine runs smoothly again, and then some more until the speed just starts to drop. At this point, screw the adjuster back in by a quarter-turn and you'll be somewhere near the optimum setting for smooth running.

IMPORTANT NOTE: After setting the mixture adjustment, re-check and, if necessary, re-adjust the idle speed.

35C. This illustration shows the correct settings for the choke fast idle adjustment (manual choke only) and the automatic anti-flooding device adjustment. See following page.

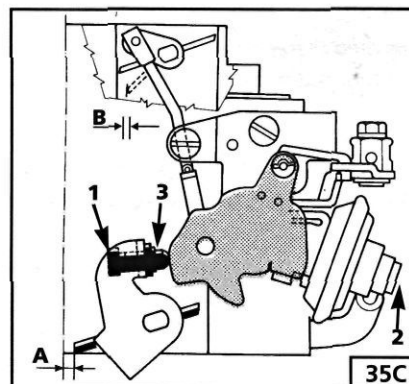

CHOKE (MANUAL) FAST IDLE ADJUSTMENT

Move the choke control lever by hand to the end of its travel and hold it there. The main butterfly aperture (A) should now be about 1.1 mm. If not, slacken the lock-nut (3), regulate the adjustment screw (1), and retighten the lock-nut.

AUTOMATIC ANTI-FLOODING DEVICE ADJUSTMENT

With the choke control lever still at the end of its travel as described in the previous paragraph, the strangler butterfly aperture (B) should be between 3 and 3.5 mm. If not, regulate the adjustment screw (2).

FUEL INJECTION MODELS

The idle speed and mixture settings are controlled by the Electronic Control Unit (ECU) which is 'self-learning' and is programmed to adjust itself to give the ideal settings under all conditions. No manual adjustment is possible, nor provided for. If there is a problem, see **Job 29**. You may need to take your car to a FIAT dealer, with the appropriate diagnostic equipment.

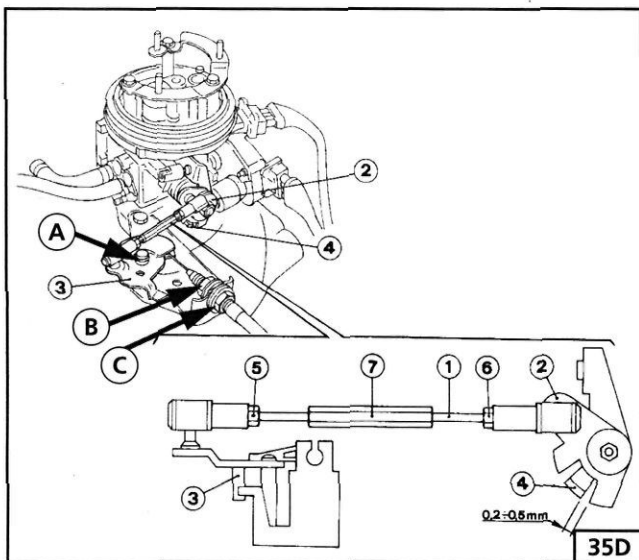

35D. At each service interval, the accelerator pivot (A)...

35E. ...should be lubricated with a dab of **TUTELA MRM2** grease.

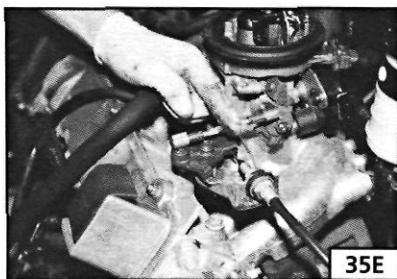

The **ACCELERATOR LINKAGE** must be adjusted correctly if the Mono-Jetronic injection system is to operate smoothly and correctly.

- Disconnect the rod (1) from the lever (2). The pulley (3) should now be against its closed stop.
- Check that the accelerator cable is not loose, but neither should it be taut, and check that there is no free play in the accelerator pedal.
- If necessary, adjust the accelerator cable by slackening the lock-nut (B) and turning the adjuster nut (C) until the cable is correctly tensioned. Then retighten the lock-nut.

Now reconnect the rod to the lever on the fuel injection unit and let the engine warm up until the cooling fan has cut in at least twice, then turn the engine off.

- With the accelerator pedal released check that the clearance between the levers (2) and (4) is between 0.2 and 0.5 mm.
- If necessary, loosen the lockouts (5) and (6). Use a spanner on the adjuster nut (7) to tighten or loosen the rod (1) until the clearance is between 0.2 and 0.5 mm.
- Retighten the adjuster nuts (5) and (6).
- Finally, make sure that with the accelerator pedal completely depressed, the butterfly in the fuel injection unit is fully open.
- If not, the accelerator cable may be too taut or the clearance between the levers (2) and (4) may be re-adjusted, keeping them within the acceptable tolerances.

Q Job 36. Check emission control systems.

PETROL INJECTION MODELS ONLY

36A. On petrol-injected Tipos and Tempras, sophisticated emission control equipment is fitted and must be tested with a proper emissions tester.

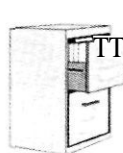
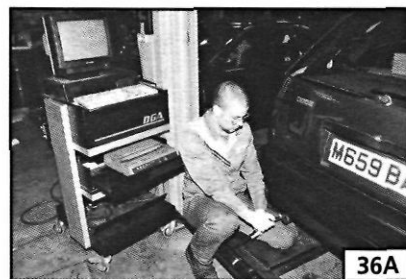

FACT FILE: EMISSION CONTROL SYSTEM

36B. The main features of the system are:

- an **Electronic Control Module Unit or (ECU)** (1) - the 'computer brain', which is programmed to alter the car's fuel and ignition settings according to information received from various sensors.
- a **catalytic converter** (2) in the exhaust system, to convert CO and other gases to less harmful gases.
- a **Lambda sensor** (3) in the exhaust manifold or front pipe (according to model) to detect the 'tune' of the exhaust gases and give a signal to the ECU.
- a petrol **evaporation control system**, to cut down on petrol vapour emissions from the fuel tank.
- **part 4** is the 'upstream' emission test point. See **Job 29**.

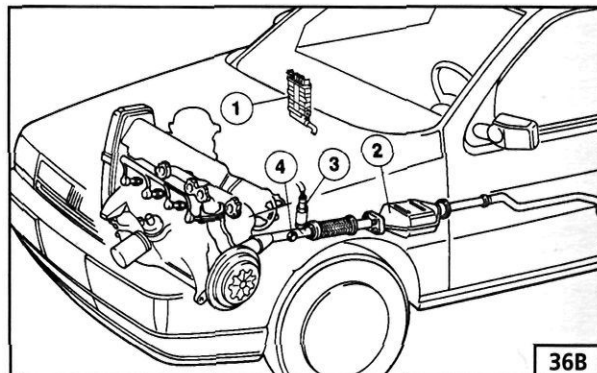

ELECTRONIC CONTROL MODULE: The ECU is not an item that requires any servicing. If you think it might be faulty, ask your FIAT dealer or fuel injection specialist to check it for you. This must be done by someone with the correct FIAT plug-in diagnostic equipment and data.

CATALYTIC CONVERTER: The CAT is not serviceable. If it fails, you will be told at the MoT test. Replacement is expensive, so we recommend you obtain a second opinion before replacing the 'cat'.

LAMBDA SENSOR: For information concerning the sensor, see Job 37.

36C. CHARCOAL

CANISTER: This unit is located behind the car's front panel, and does not need regular servicing. Check the canister one-way valve (see Chapter 6, Repairs and Replacements, Part F, FUEL AND EXHAUST for illustration) by disconnecting it and trying to blow through both ends. You should only be able to blow air towards the canister, not away from it. If the valve is faulty, renew it, making sure that it is fitted the right way round.

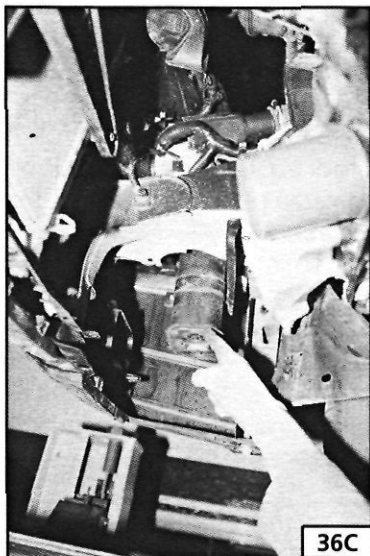

Q INSIDE INFORMATION: If the canister is flooded with petrol, it is probable that one of the **purge valves** or **purge valve floats** is faulty. Get this investigated and rectified by a FIAT dealer. If the engine cuts out and then restarts after a while, it could be the **breather hose valve**, fitted under the fuel filler neck. This one-way valve allows air to enter the tank as the fuel level falls, otherwise an air lock can prevent fuel reaching the engine. To test the valve, take off the pipe clips, remove the valve and test it as for the canister one-way valve, above. It should allow air to pass into the tank, but not the other way. **B**

LJ Job 37. Check Lambda sensor.

PETROL INJECTION MODELS ONLY

For a description of how the sensor works, see Job 36, FACT FILE: EMISSION CONTROL SYSTEM. It should be checked at the recommended interval - the cost of checking and replacing the sensor is far less than that of having to replace the catalytic converter because it has been polluted due to a sensor fault.

making it easy!

• Replacement of the sensor is a simple job (see Chapter 6, Repairs and Replacements, PART F: FUEL AND EXHAUST), but it can only be tested by your FIAT dealer with the correct equipment.

- If the sensor is faulty, have it renewed by your dealer.
- Lambda sensors are very delicate and easily damaged. It is not likely that you would be able to return one to the supplier if you fitted it yourself.
- Lambda sensors are only fitted to cars with a catalytic converter.

Job 38. Check/adjust diesel idle speed.

To accurately check and adjust the diesel's idle speed you need a diesel-specific rev-counter. If you're happy with the idle speed, leave well alone. But if you're convinced the idle is incorrect, it's best to take the car to a FIAT dealer. If you wish to adjust the speed yourself, get the engine to normal operating temperature, and check there is some free play in the accelerator cable before proceeding.

ADJUSTMENT - BOSCH PUMP

38A. Adjust the idle speed, which should be approximately 800 rpm, by slackening the lock-nut of the adjuster screw (1) then turning the screw inwards to increase the speed - or outwards to decrease. Retighten the lock-nut when the speed is correct.

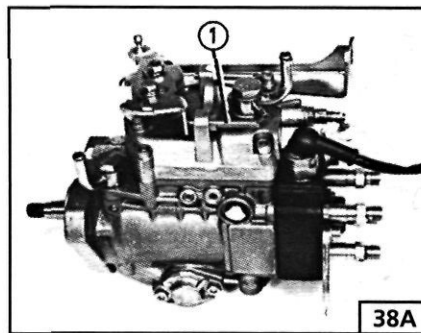

ADJUSTMENT - LUCAS/ROTODIESEUCAV PUMP

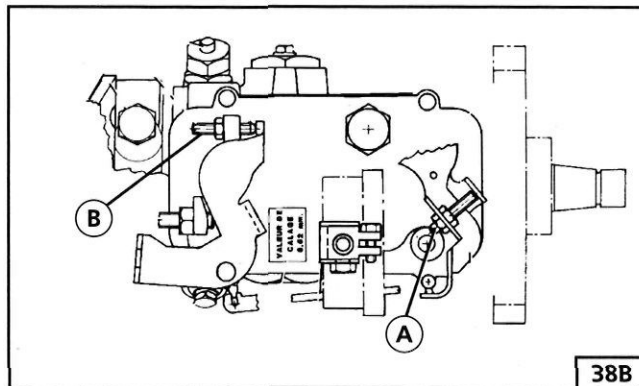

38B. Adjust the idle speed, which should be approximately 800 rpm, by slackening the lock-nut of the adjuster screw (A) and turning the screw to give the desired speed. Retighten the lock-nut, then rev the engine high and allow it to return to idle. If it goes below idle speed (i.e. it threatens to stall, or does stall), or if it decelerates too slowly, slacken the lock-nut of the adjuster screw (B), adjust it and check the deceleration again. Repeat as necessary to achieve comfortable deceleration without stalling, then tighten the lock-nut.

ZI Job 39. Check/adjust diesel injection timing.

Although a check of the injection timing is scheduled as a service item, there is no reason why the timing should have altered if the pump mounting bolts are tight and the pump has not been disturbed. Injection timing is best checked dynamically by a FIAT dealer or diesel specialist using specialised equipment. If you want to check the timing statically, and you have access to a dial gauge and the necessary adaptor to fit it to the pump, proceed as follows:

39A. Slacken the injection pump flange nuts - one can be seen (A) in illustration 39B - and rear support bracket lower bolt. Make sure that the manual cold start control lever (at the dashboard, where fitted) is fully off.

BOSCH PUMP ONLY

39B. Unscrew the plug (illustration 39A, part B) at the rear of the injection pump, and screw in a Bosch pump dial gauge and adaptor.

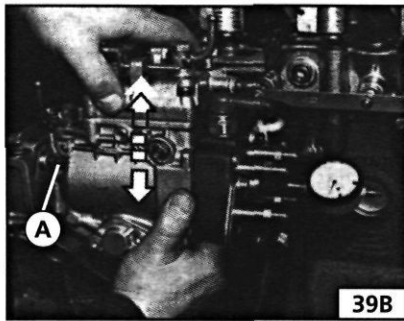

(The FIAT tool number for this is no. 1865090000.) With the tool fully screwed in, turn the engine in the opposite direction to normal rotation until the plunger inside the pump reaches its lowest

position - as indicated by gauge movement. In this position, zero the gauge. Now turn the engine in normal direction until engine piston No. 1 is at Top Dead Centre. The dial gauge should read 1 mm if the timing is correct. If it isn't, gently turn the injection pump housing relative to its mounting until the correct measurement is shown on the gauge. Now lock up the pump flange nuts and rear support bracket bolt. Remove the tool and refit the blanking plug to the back of the pump. Adjust the idle speed if necessary. See Job 38.

LUCAS/ROTODIESEUCAV PUMP ONLY

39C You will find a label attached to the top of the injection pump, quoting the correct timing measurement in millimetres. Slacken the pump flange nuts (as in, illustration 39B, part A) and the rear support bolt (as in, illustration 39A, part A). Remove the plastic cap from the pump top. Now turn the engine crankshaft in the opposite direction to normal rotation by about 20 degrees. Using either FIAT tool No. 1865091000 or, with the

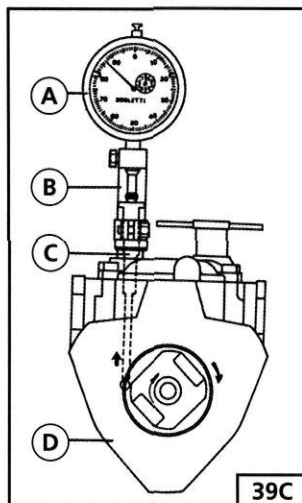
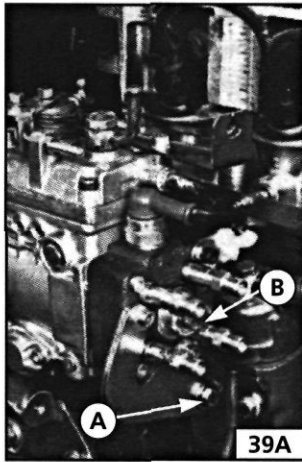

necessary Lucas dial gauge (A), the holder (B) and the probe (C) threaded into position in place of the plastic cap, position the engine crankshaft at Top Dead Centre. Ensure that the dial gauge is fitted to its holder and the pump (D) with a pre-loading of 10-15 mm, then zero it. Slowly turn the pump body, turning the upper part away from engine block. Now, slowly turn the engine crankshaft in the normal direction of rotation until the dial gauge indicates the measurement you read off the pump label (that's the correct timing point). Tighten the pump nuts/bolt. Turn the crankshaft by two complete revolutions in the normal direction of rotation, then re-check the timing. If incorrect, repeat the timing procedure. Remove the tool and refit the plastic plug. Adjust the idle speed if necessary. See Job 38.

Q Job 40. Check inlet and exhaust manifold fixings.

Check that the inlet and exhaust manifold nuts and bolts are tightened to the correct torque. See Chapter 3, Facts and Figures.

d Job 41. Check exhaust system.

Examine the silencer and exhaust pipes and joints for corrosion and signs of leaking, indicated by a 'sooty' deposit at the point of the leak.

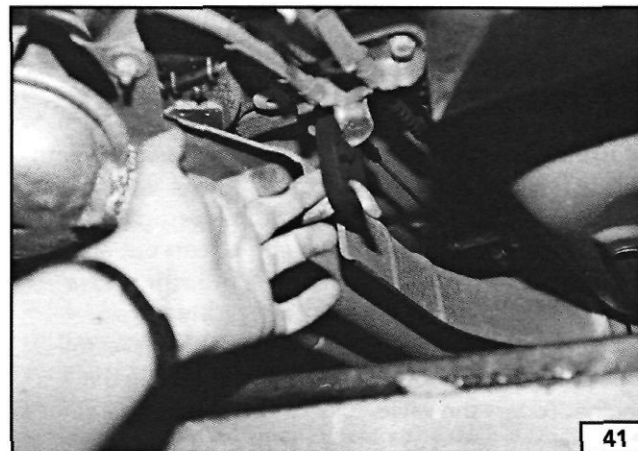

41. Also check the condition of the rubber 'hangers' that hold the system to the car. If any are missing or broken, the exhaust system can fracture due to extra stresses. Stretch the rubber, and look for cracks.

making it easy!

- If you suspect a leak but its location isn't obvious, start the engine and pressurise the system by holding a piece of board against the tailpipe.
- Under pressure, the leak should be more noisy and obvious.
- Don't burn yourself on the exhaust!

PART F: STEERING AND SUSPENSION

Q Job 42. Check front wheel bearings.

In order to check for wear:

- raise the front of the car on axle stands (see *Chapter 1, Safety First!*)
- place the gearbox in neutral
- pull the handbrake securely on and chock the rear wheels

Try spinning each wheel (as far as possible with a front-drive car), feeling for rough rotation. Rock the wheel about its centre, feeling for excess bearing play.

D INSIDE INFORMATION: If a wheel bearing is worn, you will normally hear a noise on the outer, loaded bearing when cornering. **B**

Q Job 43. Check front suspension.

BOTTOM BALL JOINT

Jack up the car underneath the suspension lower arm (wishbone), so that the wheel is two inches off the ground. See *Chapter 1, Safety First.*

43A. Place a long, rigid bar between the ground and the bottom of the tyre tread, and carefully 'jog' the wheel upwards repeatedly while a helper looks at and feels the



lower balljoint for vertical movement. The helper should NOT lie under the car, and you should be careful not to rock the car off the jack. Also examine the ball joint gaiter for any damage or leakage of grease - a simple, visual examination. You will have to replace the wishbone assembly if the gaiter is damaged. See *Chapter 6, Repairs and Replacements* for information.

TRACK CONTROL ARM INNER BUSHES

43B. Further raise the car and support it on an axle stand under the subframe so that the suspension on the side being checked can hang free. Lever between the arm and subframe, looking for excessive movement of the bushes. Some cushioned flexing is normal. See *Chapter 6, Repairs and Replacements* for bush replacement information. One bush is at the front inner end of the wishbone...



43C. ...and the other is at the rear of the wishbone.



SUSPENSION STRUT/SHOCK ABSORBER

43D. Examine the shock absorber, which is enclosed inside the coil spring, for leaks, looking for signs of a 'damp' oil stain seeping from underneath the top half of the shock absorber body.

The top of the strut/shock absorber is mounted in a rubber bush which can be checked for softness, cracking or deterioration from inside the engine bay.



BOUNCE TEST: Try 'bouncing' each front corner of the car in a rhythmical motion, pressing down as hard as you can. When you let go, the movement should continue for no more than one-and-a-half rebounds. If it does so, this is a sure indication that the shock absorber is worn and should be replaced. If one of the front shock absorbers needs replacing, replace both, for safety reasons.

ANTI-ROLL BAR BUSHES

43E. Check the outer mountings, on the suspension, and the body mountings.



Q Job 44. Check steering column, rack and TREs.

44A. Drive the car on to car ramps, firmly apply the handbrake and chock the rear wheels. Get your helper to sit inside the car, turn the ignition key to the 'MAR' (ON) position to release the steering column lock. Now, move the steering wheel repeatedly about 100 mm (4 in.) each way while someone checks for free movement in



each track rod end (TRE). Also, look out for a split gaiter. Replace the TRE if the gaiter is split, or it will rapidly fail.

H INSIDE INFORMATION: Try placing your hand over the TRE as the steering is moved. If there are any signs of wear, replace the TRE. **Q**

STEERING COLUMN

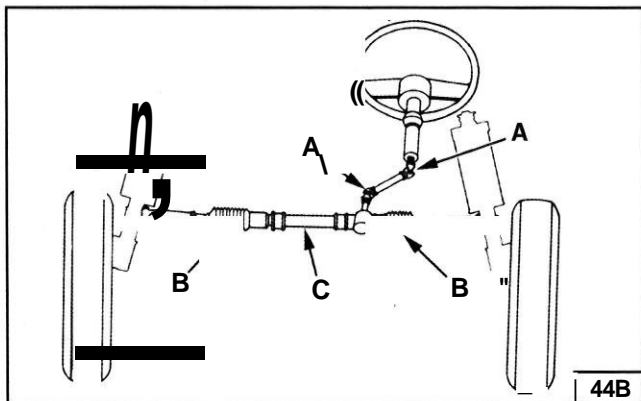

44B. The steering column has two universal joints (A) which need to be checked for wear. While your assistant is turning the steering wheel, check to see if there is any movement in the universal joints.

44C. The upper joint is found alongside the foot pedals.

Q INSIDE INFORMATION: Place your hand over the joint - you can usually feel the movement better than you can see it. If there is ANY movement at all, play at the steering wheel will be greatly exaggerated - replace the faulty universal joint. **Q**

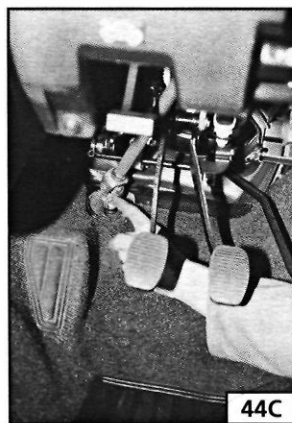

STEERING RACK GAITERS

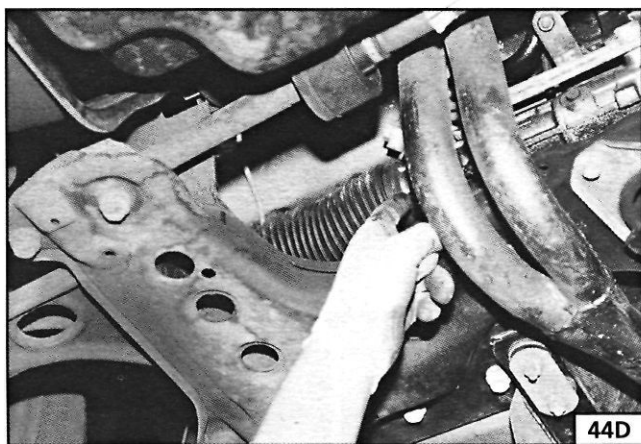

44D. Q INSIDE INFORMATION: Check the right hand gaiter from beneath; the left-hand from inside the engine bay. **Q**

Turn the ignition key to the 'MAR' (ON) position but take care not to start the engine. Turn the steering wheel to full right lock. From underneath the bonnet, examine the gaiter (see illustration **44B**, parts B) on the left-hand side, which will now

be fully extended. Check visually for splits or oil leakage. Turn the steering wheel to the opposite lock and examine the gaiter (B) on the other side of the rack. If necessary, replace IMMEDIATELY - the rack will rapidly be ruined if the gaiter is split.

Also, watch the steering rack body (C) to see if it is firmly attached. If there is any movement between the rack and its mountings, check the securing bolts for tightness.

LJ Job 45. Check power steering fluid.

45A. When the engine is cold, the power steering fluid should not drop below the LIVELLO (level) mark (B) on the reservoir (A)...

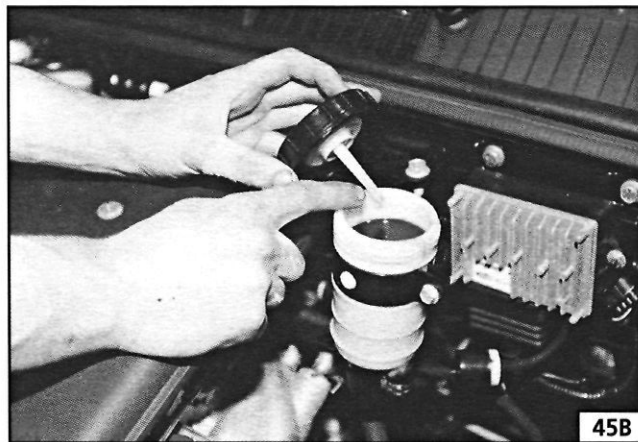
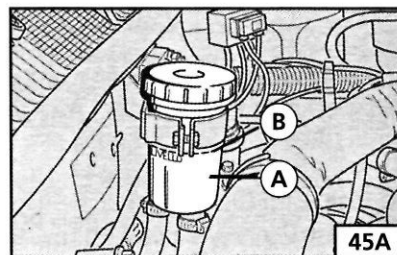

45B. ...or the mark on the dipstick, as shown. It's okay for the level to appear too high when the engine is hot.

IMPORTANT NOTE: The reservoir 'floats' around the engine bay - in different places in different models.

d Job 46. Check rear wheel bearings.

Tipo/Tempra rear wheel bearings are sealed in their hubs and are usually very long lived. See the checking procedures described in **Job 42**, but remember not to apply the handbrake! Also note that the rear wheels will be easier to spin than the fronts.

U Job 47. Check rear suspension.

Chock the front wheels, jack the rear of the car, and place stands under the axle, as close to the wheels as possible. Lower the car onto the axle stands.



47. Check the subframe mountings (x4), the trailing arm bush pivot bolts, the shock absorber lower mounting bolts and the anti-roll bar mounting bolts for tightness. Check the condition of the mounting bushes by levering them with a screwdriver. Replace if excessive movement or bush deterioration are noticed. See *Chapter 6, Repairs and Replacements*.

REAR SHOCK ABSORBERS

Look for signs of leaks coming from underneath the top part of each rear shock absorber and replace if necessary. Check the top and bottom rubber mounting bushes. If any are soft or split they must be replaced. Check that the bump stops are present and correct.

BOUNCE TEST: Bounce-test the shock absorbers as in **Job 43**.

[J] Job 48. Check wheel bolts for tightness.

Remove each wheel bolt in turn and ensure that they run smoothly. Clean the threads, if necessary. Refit and check that all are tightened to the correct torque - see *Chapter 3, Facts and Figures* - using a torque wrench.



48

PART G: BRAKING SYSTEM

SAFETY FIRST!

- Before raising the car, see **Chapter 1, Safety First!**
- Also, be sure to read the section on **BRAKES AND ASBESTOS** in **Chapter 1, Safety First!** for further important information.
- Your car's brakes are its most important safety-related items. Do NOT attempt any work on the braking system unless you are fully competent to do so.
- if you have not been trained in this work, but wish to carry it out, we strongly recommend you have a garage or qualified mechanic check your work before using the car on the road.
- Always start by washing the brakes with a proprietary brand of brake cleaner - brake drums removed where appropriate - and never use compressed air to clean off brake dust.
- Always replace brake pads and/or shoes in complete 'axle' sets of four - never replace them on one wheel only.
- After fitting new brake shoes or pads, avoid heavy braking for the first 150 to 200 miles (250 to 300 km), except in an emergency.

Job 49. Check front brakes.

You can check the thickness of the brake pads by looking through the 'window' in the caliper. However, this isn't recommended unless you are experienced and know what you are looking for, and you can't check the caliper or clean out accumulated brake dust.

Therefore, checking the Tipo's and Tempra's brake pads involves the same amount of work as changing them. For that reason, brake pad replacement is covered here in detail rather than in *Chapter 6, Repairs and Replacements*.

49A. Start by raising the wheel to be worked on and supporting it on an axle stand. Remove the road wheel - see *Chapter 1, Safety First!*

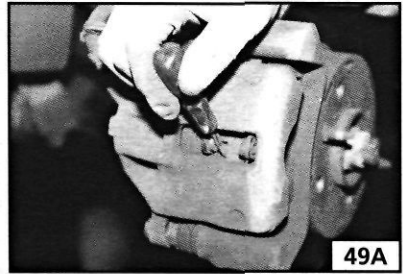

49A

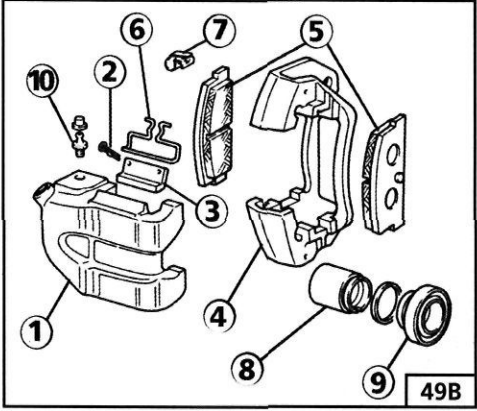

49B. This drawing illustrates the various components of the front brake assembly.

49C. Remove the bottom caliper bolt, using an open-ended spanner to allow the bolt to turn. ALWAYS refit with NEW FIAT caliper mounting bolts - they are a special type.

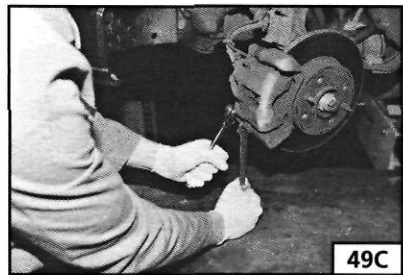

49C

49D. Slacken the top bolt, swivel the caliper up and the pads come free, for checking.

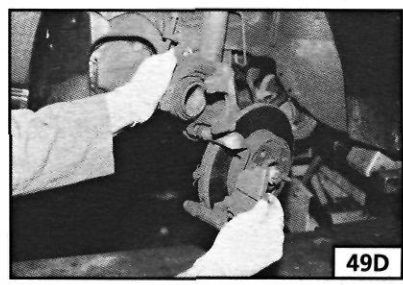

49D

IMPORTANT NOTE: If you remove the top caliper bolt, DO NOT allow the weight of the caliper to hang from the flexible hose - position it to rest on the driveshaft, or support it from the road spring using a length of wire.

Compare the thickness of the two pads - there should be no significant difference. The minimum recommended thickness of lining material is 1.5 mm, but bearing in mind the amount of time before the next service, you may wish to replace the pads before they get to this stage.

You can now check the thickness of the brake disc, which should not be below the figure given for your model in *Chapter 3, Facts and Figures*, at any point.

Mains Electricity

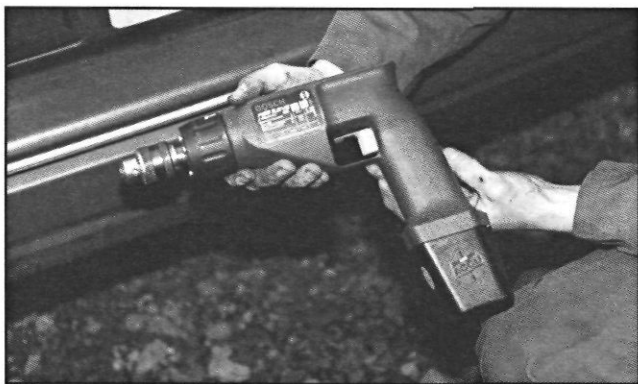

Avoid the use of mains electricity when working on the vehicle, whenever possible. Use rechargeable tools and a DC inspection lamp, powered from a remote 12V battery - both are much safer. However, if you do use mains-powered equipment, ensure that the appliance is wired correctly to its plug, that where necessary it is properly earthed (grounded), and that the fuse is of the correct rating for the appliance. Do not use any mains powered equipment in damp conditions or in the vicinity of fuel, fuel vapour or the vehicle battery.

Always use an RCD (Residual Current Device) circuit breaker with mains electricity. Then, if there is a short, the RCD circuit breaker minimises the risk of electrocution by instantly cutting the power supply.

Ignition System

Never work on the ignition system with the ignition switched on, or with the engine being turned over on the starter, or running and you are recommended never to do so.

Touching certain parts of the ignition system, such as the HT leads, distributor cap, ignition coil etc., can result in a severe electric shock or physical injury as a hand is pulled sharply away. Voltages produced by electronic ignition systems are much higher than those produced by conventional systems and could prove fatal, particularly to people with cardiac pacemaker implants. Consult your handbook or main dealer if in any doubt.

Cooling Fan

On many vehicles, the electric cooling fan can switch itself on even with the ignition turned off. This is especially likely after driving the car and parking it before turning off, after which heat rises to the top of the engine and turns the fan on, suddenly and without warning. If you intend working in the engine bay, it's best to do so when the engine is cold, to disconnect the battery, or keep away from the fan, if neither of these are possible.

Battery

Never cause a spark, smoke, or allow a naked light near the vehicle's battery, even in a well ventilated area. Highly explosive hydrogen gas is given off as part of the charging process.

Battery terminals on the car should be shielded, since a spark can be caused by any metal object which touches the battery's terminals or connecting straps.

IMPORTANT NOTE: Before disconnecting the battery earth (ground) terminal read the relevant **FACT FILE** in Chapter 5 regarding saving computer and radio settings.)

When using a battery charger, switch off the power supply before the battery charger leads are connected or disconnected. If the battery is not of the 'sealed-for-life' type, loosen the filler plugs or remove the cover before charging. For best results the battery should be given a low rate trickle charge overnight. Do not charge at an excessive rate or the battery may burst.

Always wear gloves and goggles when carrying or when topping up the battery. Acid electrolyte is extremely corrosive and must not be allowed to contact the eyes, skin or clothes.

Brakes and Asbestos

Obviously, a car's brakes are among its most important safety related items. **ONLY** work on your vehicle's braking system if you are trained and competent to do so. If you have not been trained in this work, but wish to carry out the jobs described in this book, we strongly recommend that you have a garage or qualified mechanic check your work before using the car.

Whenever you work on the braking system components, or remove front or rear brake pads or shoes: i) wear an efficient particle mask; ii) wipe off all brake dust from the brakes after spraying on a proprietary brand of brake cleaner (never blow dust off with compressed air); iii) dispose of brake dust and discarded shoes or pads in a sealed plastic bag; iv) wash your hands thoroughly after you have finished working on the brakes and certainly before you eat or smoke; v) replace shoes and pads only with asbestos-free shoes or pads. Note that asbestos brake dust can cause cancer if inhaled; vi) always replace brake pads and/or shoes in complete 'axle' sets of four - never replace the pads/shoes on one wheel only.

Brake Fluid

Brake fluid absorbs moisture rapidly from the air and can become dangerous resulting in brake failure. You should change the fluid in accordance with your vehicle manufacturer's recommendations or as advised in this book. Never store (or use) an opened container of brake fluid. Dispose of the remainder at your Local Authority Waste Disposal Site, in the designated disposal unit, not with general waste or with waste oil.

Engine Oils

Always wear disposable plastic or rubber gloves when draining the oil from your engine, i) Note that the drain plug and the oil are often hotter than you expect. Wear gloves if the plug is too hot to touch and keep your hand to one side so that you are not scalded by the spurt of oil as the plug comes away; ii) There are very real health hazards associated with used engine oil. In the words of one manufacturer's handbook "Prolonged and repeated contact may cause serious skin disorders, including dermatitis and cancer." Use a barrier cream on your hands and try not to get oil on them. Always wear gloves and wash your hands with hand cleaner soon after carrying out the work. Keep oil out of the reach of children; iii) **NEVER, EVER** dispose of old engine oil into the ground or down a drain. In the UK, and in most EC countries, every local authority must provide a safe means of oil disposal. In the UK, try your local Environmental Health Department for advice on waste disposal facilities.

Plastic Materials

Many of the materials used (polymers, resins, adhesives and materials acting as catalysts and accelerators) contain dangers in the form of poisonous fumes, skin irritants, and the risk of fire

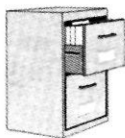

FACT FILE: BRAKE DISC WEAR SYMPTOMS

There are certain essential checks you should carry out for yourself, with brake pads removed:

- Look for any obvious grooves worn into the disc. Slight undulations are acceptable, but anything worse and the disc should be replaced.
- Look and feel for any wear-ridge on the outer edges of the disc. The depth will give an indication of wear.
- Check for corrosion of the disc surface. If any is found, the brake caliper is probably faulty, and needs checking.
- If any surface flaking is found on either side of the disc, replace them both.
- If you are not certain whether any wear is acceptable, ask your specialist or FIAT dealer to check.

Before reassembling the brake, check the condition of the brake caliper. Have an assistant **VERY SLOWLY AND GENTLY** apply pressure to the brake pedal while you watch the piston (see illustration 49B, part 8), which should move outwards. If it doesn't easily move, it is seized and the caliper should be replaced. **DO NOT** allow the piston to project more than 10 mm or it may be forced from the caliper - use a G-clamp as an 'end stop'.

49E. Check inside the caliper housing for signs of corrosion. If any is found, or the seal is damaged, the caliper should be exchanged for a new or overhauled unit from your FIAT dealership.

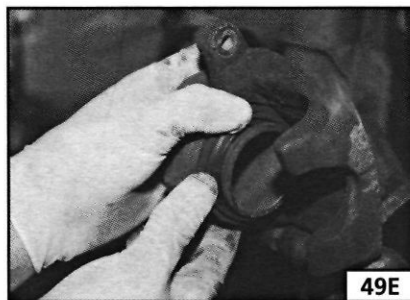

Examine the piston's protective gaiter (see illustration 49B, part 9) for splitting and fluid leaks. This one is in poor condition and the caliper requires immediate replacement.

making it easy!

- In order to fit new pads, the caliper piston must be pushed back into the bore.
- Use an old battery hydrometer to draw about half of the fluid from the master cylinder.
- Push the piston back into the caliper, using a G-clamp.
- Keep an eye on the master cylinder so that it doesn't overflow as fluid is pushed back up the pipe.

49F. Before fitting the pads, put a light smear of brake grease (NOT ordinary grease) on the pads' metal backplates at the points shown.



IMPORTANT NOTE: Be very sparing or grease could migrate to the friction linings!

WEAR SENSORS

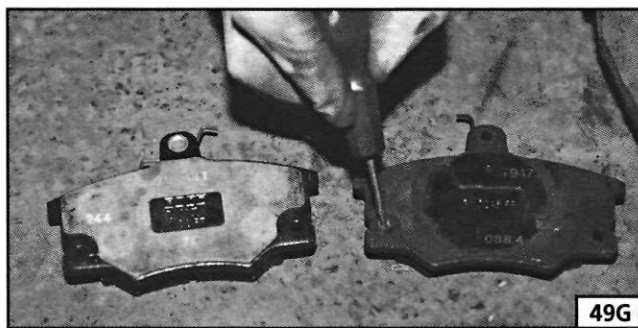

49G. If these are fitted, the contact has to be transferred from the old backing plate to the new. Pull off the wire, push out the brass pin...

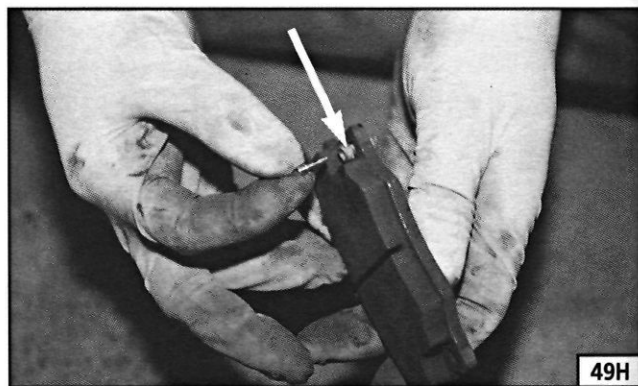

49H. ...and push out the nylon bush (arrowed). Reassemble on the new pad and reattach the wire.

IMPORTANT NOTE: After fitting the pads, apply the brakes firmly several times to adjust them.

- Job 50. Check rear brakes.

SAFETY FIRST!

Read SAFETY FIRST at the start of Job 49 before proceeding!

GENERAL. The majority of Tipo/Tempra models are fitted with rear drum-type rear brakes, but models with ABS anti-lock braking have a disc-and-caliper arrangement instead.

Slacken the wheel bolts, raise the wheel, remove it and support the car with an axle stand. Make sure that the wheels remaining on the ground are chocked in both directions and that the handbrake is off.

DRUM REAR BRAKES

making it easy!

- If the drum sticks, try:
- screwing a pair of bolts into the two threaded holes in the drum. Evenly tightening the bolts will force the drum off the shoes.
 - tapping carefully around the drum with a hide mallet to help loosen it.

50A. Remove the two bolts (one or both of them also the wheel positioning stud/s)...

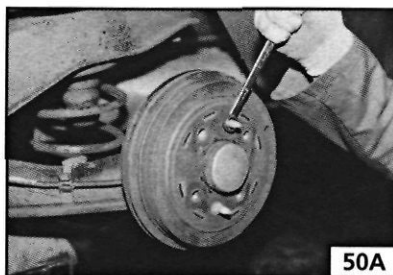

50A

50B. ...and remove the drum. Clean the inside of the drum and the brake with aerosol brake cleaner. If the drum is badly scored or cracked, replace it.

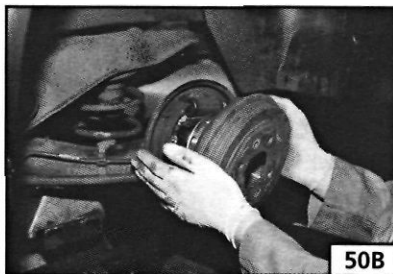

50B

Examine the brake shoes for wear or oil contamination. If the latter, the wheel cylinder is probably leaking (see **50Q** and the shoes will have to be scrapped. FIAT recommend a minimum 1.5 mm shoe lining thickness, but it's advisable to replace shoes well before they're this thin.

50C. Fold back each of the two rubbers on the wheel cylinder. Any fluid found inside requires a new cylinder. However, newish cylinders will have a little of their special grease still in there.

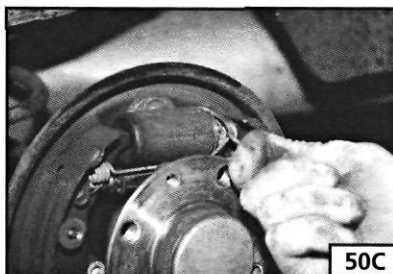

50C

50D. Take special care to wash all the brake dust away from the automatic adjuster mechanism with aerosol brake cleaner. Make sure that it is not seized but if it is, you will have to strip down the assembly (see *Chapter 6, Repairs and Replacements*) and free off or replace. Add brake grease very sparingly (NOT ordinary grease) to the mechanism.

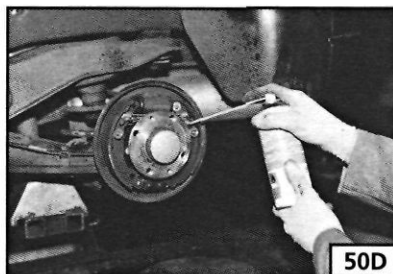

50D

IMPORTANT NOTE: For information on replacing missing or damaged springs, brake shoes or wheel cylinders, see *Chapter 6, Repairs and Replacements*.

DISC REAR BRAKES

With the rear of the car raised and safely supported (see *Chapter 1, Safety First*) and the rear wheels removed, brake pad inspection can be carried out by looking through the aperture in the caliper body. However, as for the front brakes, you are recommended to remove the calipers. See notes at the start of *Job 49*. The pads should be replaced as detailed in *Chapter 6, Repairs and Replacements*. Minimum thickness is 1.5 mm- but don't let them get this low!

50E. Using a pair of spanners, as shown, remove the two retaining bolts. These bolts are self-locking and FIAT recommend that they should be replaced each time they are removed or if they become loose.

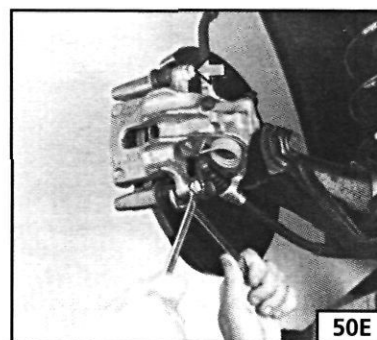

50E

50F. So that you don't have to bleed the system, release and disconnect the parking brake cable (arrowed) and lift the caliper out of the way, suspending it on a piece of wire so that no strain is placed on the flexible hydraulic hose.

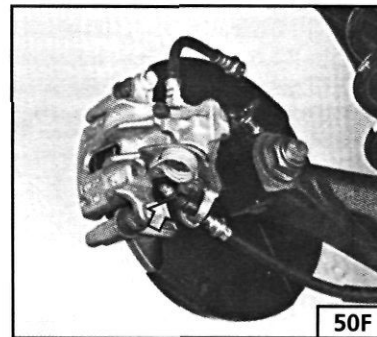

50F

50G. The brake pads are simply lifted away.

IMPORTANT NOTE:

- Follow *Job 49* carefully for further information such as on checking the caliper seals, the condition of the disc, and lubricating the pad backing plates.
- Before fitting new pads, turn the caliper piston clockwise until it goes fully in.
- Pump the brake pedal repeatedly to adjust the pad positions and top up with fresh brake fluid.

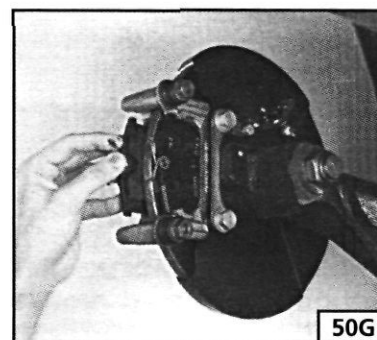

50G

□ Job 51. Check/adjust handbrake.

The handbrake is intended to 'set' itself in use as the rear brake self-adjusters operate. If the handbrake seems not to work, even though lever travel is not excessive, remove the rear drums and examine the brake shoes (see *Job 50*) and the self-adjuster mechanism, to ensure that it has not seized. The handbrake may need adjusting when, after a time, the handbrake cable stretches or if the rear brake friction materials are replaced.

IMPORTANT NOTE: On rear disc brake cars, the handbrake-end of the mechanism is the same as for drum brake cars. At the brakes, the clearance is adjusted automatically, provided that the adjuster, built in to the caliper assembly, has not seized. If it has, replace the caliper.

SAFETY FIRST!

Raise the rear of the car to adjust the handbrake. It is ESSENTIAL to ensure the front wheels are securely chocked in both directions, and that axle stands are used to support the car.

51. Apply the handbrake lever by one 'click' of the ratchet. From inside the car, turn the adjusting nut (a) until the cable is drawn taut. Pull the handbrake up two

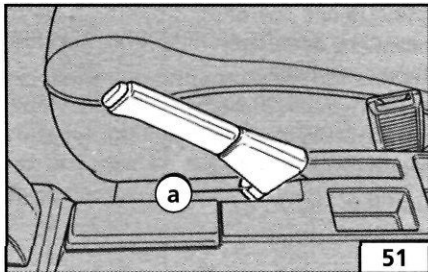

more 'clicks' and check that both rear wheels are now 'locked'. Check also that both rear wheels are completely free when the handbrake is fully OFF. When everything works properly, lower the car to the ground, and check again that moving the handbrake through about three notches is sufficient to hold the car stationary. A proper check of handbrake efficiency can only be carried out by a garage with a 'rolling road' brake tester.

Job 52. Check brake pipes.

FLEXIBLE HOSES

Check the flexible brake pipes that connect the calipers to the metal pipes on the body. Try bending back on themselves

those that are not contained in a protective coil, and look for any signs of cracking, particularly at the bends. Check them all for signs of rubbing, splitting, kinks and perishing of the rubber. Check hoses for 'ballooning' with the brake pedal pressed.

RIGID PIPES

Check all rigid pipes for signs of damage or corrosion and check that all of the locating clips are sound and in place.

d Job 53. Change brake hydraulic fluid.

Change the brake fluid at the recommended interval. See *Chapter 6, Repairs and Replacements, PART H: BRAKES Job 15.*

Q INSIDE INFORMATION: Brake fluid absorbs water from the air. This corrodes brake components and can cause total brake failure. With brakes applied heavily, the fluid can heat to above 100 degrees Celsius, the water vaporises, and the pedal goes to the floor! Q

PART H: BODYWORK & INTERIOR

LJ Job 54. Lubricate hinges and locks.

Apply a few drops of light oil (from either an aerosol or oil can) to the hinges of the bonnet, doors and tailgate. Dip the door/tailgate key in graphite powder and insert the key to lubricate the lock barrels. Grease the door and tailgate latch mechanism (aerosol grease is handy), the bonnet release mechanism (and the tailgate's, if applicable) and the cable end. Don't forget the fuel tank flap hinge and the locking cap - it's a stopper when it jams!

Job 55. Check windscreen.

Clean the windscreen with a proprietary glass cleaner and examine it for stone chips, cracks and scoring. While some degree of damage is acceptable, the strict MoT Test regulations limit the amount and position of such defects. Some screen chips can be repaired and made invisible.

Q Job 56. Check seat and seat belt mountings.

Your car's seat and safety belt mountings and backrest adjustment locking mechanism will be checked as part of the annual test, but it pays to check them beforehand. Also, regularly check that the seat belts: a) retract easily and smoothly, and b) 'hold' when you snatch them, or under sharp braking.

Q Job 57. Check headlight alignment.

Some vehicles are fitted with an automatic headlight levelling device. On these vehicles, each of the headlights is adjusted according to the vehicle height and no height levelling adjustment is possible.

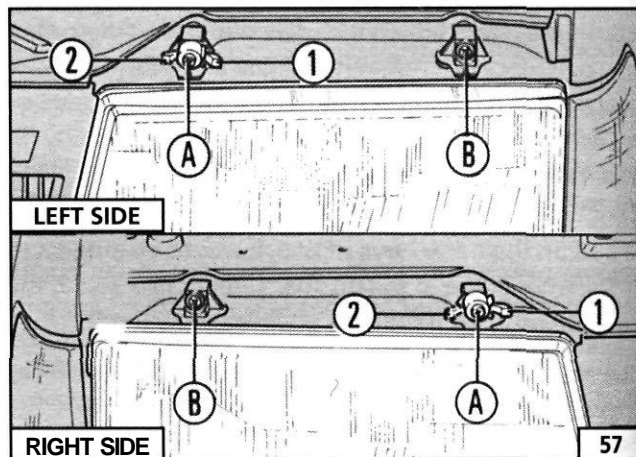

57. On the majority of vehicles, there is a manual height adjuster. When the vehicle is unladen, the lever should be in position (1); when fully laden, in position (2). The height adjusters are on the inner side of each headlight and are visible with the bonnet open. Make sure that the adjusters are set to the 'unladen' position before the headlights are adjusted. Don't confuse the beam correctors with the vertical alignment screw (A) and the horizontal adjuster screw (B).

Q Job 58. Check underbody.

Check the condition of the underbody for damage and corrosion. Take a tin of waxy underbody seal and a brush under the car and replace any missing underbody seal.

• **Job 59. Check spare tyre.**

This job should ideally be carried out every month or two - you never know when you're going to need that spare! But if you haven't remembered, do it at the time shown on the Service Interval Chart at the latest.

H INSIDE INFORMATION: Put in the maximum recommended pressure for heavy-duty use - it's always easier to let some air out if necessary, than to put some in. Lift the spare out check the 'hidden' lower side wall for cracking. See **Job 6. Q**

You'll have to remove the toolkit and the wheel to get at the valve - under the boot floor on most models but to one side of the rear compartment on Estate versions.

• **Job 60. Change pollen filter.**

When fitted to the fresh air intake, replace it at the scheduled mileage interval.

Q Job 61. Replace airbag gas generator.

Have your FIAT dealer replace the airbag gas generator 10 years after the car was built - see the label inside the car's glove compartment door.

PART I: ROAD TEST

Q Job 62. Road test and specialist check - after every service.

Before you can claim to have 'finished' working on your car, you must check it, test it, and, if necessary, have a qualified mechanic check it over for you.

If you are not a qualified mechanic, we strongly recommend having someone who is a properly qualified mechanic - your FIAT dealership perhaps - inspect all of the car's safety-related items after they have been worked on at home and before using the car on the road.

- Before setting out, check that the lights, indicators and in-car controls, as well as seat belts and seat adjustments, all work correctly.
- Run the car for several minutes before setting out then turn off, check fluid levels and check underneath for leaks.
- Check that the steering moves freely in both directions and that the car does not 'pull' one way or the other when driving in a straight line - but do bear in mind the effect of the camber on the road.
- Make sure that the brakes work effectively, smoothly and without the need for 'pumping'. There should be no juddering or squealing.
- Check that the car does not 'pull' from one side to the other when you brake firmly from around 40 mph. (Don't cause a skid and don't try this if there is any following traffic.)

WURTH PRODUCTS FROM FIAT



A. Wurth produce a huge range of very high quality, FIAT-approved products, from zinc-rich aerosol paints, rust-proofing products and the safety-related items shown here...

B. ...to electrical connectors and tools and that wonderful 'shrink-fit' wire insulation tubing - slide it on, heat it up, and it 'shrinks' into place and can't come undone again. See your FIAT dealer or other specialist supplier for the vast range of top-quality Wurth products.



CHAPTER 6 REPAIRS AND REPLACEMENTS

This chapter shows you how to remove and overhaul all the major 'wearing' parts of the car. We deliberately don't show how to rebuild major components, such as the gearbox, or differential. You are much better off, in terms of time, cost and the provision of a guarantee, to buy a replacement unit.

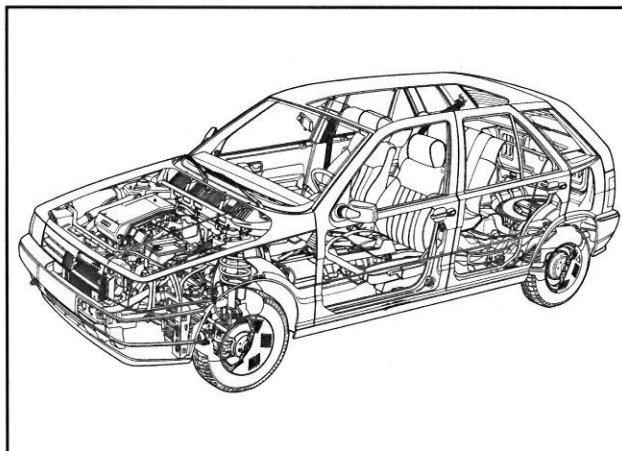

The same applies to major electrical components, such as alternator and starter motor. If, as we recommend, you stick to 'original' FIAT replacement parts, you will maintain the original quality of your car.

Chapter Contents

| | Page No. | | Page No. |
|------------------------------------|----------|---------------------------------|----------|
| PART A: ENGINE | 65 | PART f: FUEL AND EXHAUST | 116 |
| PART B: TRANSMISSION AND CLUTCH | 98 | PART G: STEERING AND SUSPENSION | 127 |
| PART C: COOLING SYSTEM | 106 | PART H: BRAKES | 134 |
| PART D: IGNITION | 107 | PART I: BODY AND INTERIOR | 143 |
| PART E: ELECTRICAL AND INSTRUMENTS | no | | |

Illustration and Section Numbers

- In this chapter, each area of the car is dealt with in a different PART of the chapter, such as, **PART A: ENGINE**.
- Each job in each PART has a separate identifying number. For example **Job 2. Cylinder head removal**.
- Every Job is broken down into easy-to-follow Steps, numbered from 1-on.
- Illustrations are numbered so that you can see at a glance where they belong!
- The illustration **Job 1-3** (in PART A) for example, relates to the text in **Job 1, Step 3**.

SAFETY FIRST!

- Before carrying out any of the work in this chapter, be sure to read and understand **Chapter 1, Safety First!**
- Be sure to read any safety notes supplied with any of the materials for equipment you purchase in connection with the work described in this chapter.
- If you are not sure about your competence or skills in carrying out any of the work described in this chapter, have the work carried out by your FIAT dealership.



FACT FILE: TIPO and TEMPRA ENGINE TYPES

PETROL ENGINES: The engines covered by this manual are by far the most commonly found in the UK. There may be the odd few with different capacities or specifications which have been imported from other countries but even they are usually similar. Here we are concerned with one type of OHC (overhead camshaft) PETROL engine, in 1372cc (1400) and 1581cc (1600) capacities. They are best identified by the fact that the 1400 has its

distributor mounted on the side of the cylinder block and the 1600 has a distributor which is mounted on the end of the camshaft, flywheel end.

DIESEL ENGINES: The Diesel engines covered here are the 1697cc (1700), the 1929cc (1900) and the 1929cc (1900) turbo. It would take a trained eye to spot any differences between the normally aspirated engines, but the turbo mounted on the exhaust manifold together with its associated extra 'plumbing' easily identifies the most powerful version.

PART A: Contents

Job 1. Petrol engine. Timing belt - replacement and adjustment.

Job 2. Petrol engine. Cylinder head - removal.

Job 3. Petrol engine. Cylinder head and camshaft housing - refitting.

Job 4. Petrol engine. Cylinder head - dismantling and overhauling.

Job 5. Petrol engine - dismantling.

Job 6. Petrol engine - checking and reassembly.

Job 7. Petrol engine. Valve clearances - adjustment.

Job 8. Petrol engine/transmission - removal.

Job 9. Petrol engine/transmission - refitting.

Job 10. Petrol engine/transmission (removed from car) - separation.

Job 11. Petrol engine/transmission (removed from car) - reconnection.

Job 12. Petrol engine. Mountings - replacement,

Job 13. Diesel engine. Timing belt - replacement and adjustment. -

Job 14. Diesel engine. Cylinder head - removal.

Job 15. Diesel engine. Cylinder head - refitting,

Job 16. Diesel engine. Cylinder head - overhaul,

Job 17. Diesel engine. Valve clearances - adjustment,

Job 18. Diesel engine - removal,

Job 19. Diesel engine - refitting,

Job 20. Diesel engine. Mountings - replacement,

Job 21. Diesel engine/transmission (removed from car) - separation.

Job 22. Diesel engine/transmission (removed from car) - reconnection.

Job 23. Diesel engine - dismantling,

Job 24. Diesel engine - reassembly.

Job 1. Petrol engine. Timing belt - replacement and adjustment.

IMPORTANT NOTE: It is false economy to refit a used timing belt. If the belt breaks, it will cause complete engine failure so always fit a new one.

Step 1:

Disconnect the battery and remove the alternator drivebelt as described in **PART C: COOLINGSYSTEM**.

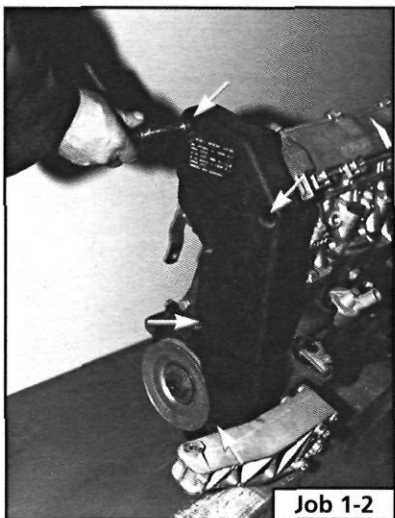

Job 1-2

Step 2: Take off the timing belt cover. This is held by a total of four bolts (arrowed).

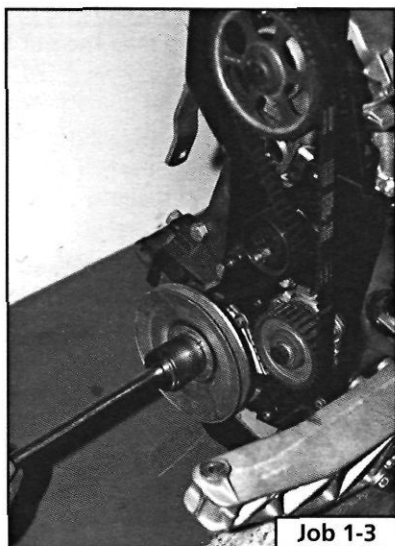

Job 1-3

Step 3: Take off the crankshaft pulley nut and remove the pulley.

making it easy! * The crankshaft pulley nut will be difficult to turn.

• If the engine is in the car, engage a gear (or 'Park' in the case of an automatic) and have an assistant hold the footbrake down very firmly. This will stop the engine from turning.

• Alternatively, with the starter motor removed, you can have a helper prevent the flywheel ring gear from turning with a large screwdriver.

Q Step 4: Before removing the belt, put the pulley nut back onto the crankshaft, take the car out of gear (if the engine is still in the car) and remove the spark plugs. You can now turn the engine in a clockwise direction using the refitted crank pulley nut - without the pulley, of course!

• **Step 5A:** With the timing belt still in place, turn the engine so that the timing mark on the camshaft sprocket lines up with the one on the front cover. On some engines, the front cover looks like this...

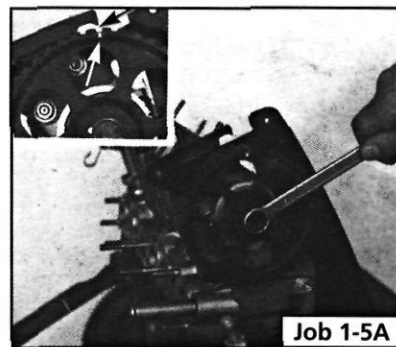

Job 1-5A

J Step 5B:

...while on the majority, it looks like this. The top part of the cover backplate slides out so that the plastic pip is level with the camshaft sprocket. Turn the sprocket so that the timing mark on the sprocket lines up with this pip.



Job 1-5B

LJ Step 6A: You must also check that the mark (a) on the timing belt pulley lines up with the reference mark (b) on the oil seal housing. It will be essential that all of these marks align when the new belt is fitted!

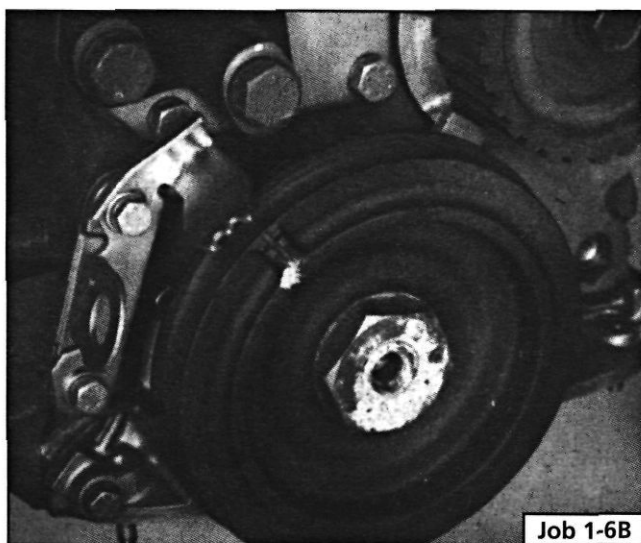
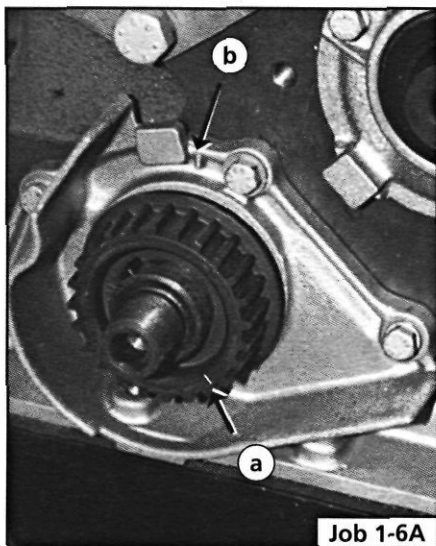

LJ Step 6B: On earlier engines rotate the crankshaft so that the reference mark on the driving pulley is in line with the TDC reference mark on the front cover. If the engine is in the vehicle, position the crankshaft at TDC using the reference marks on the flywheel and bellhousing window.

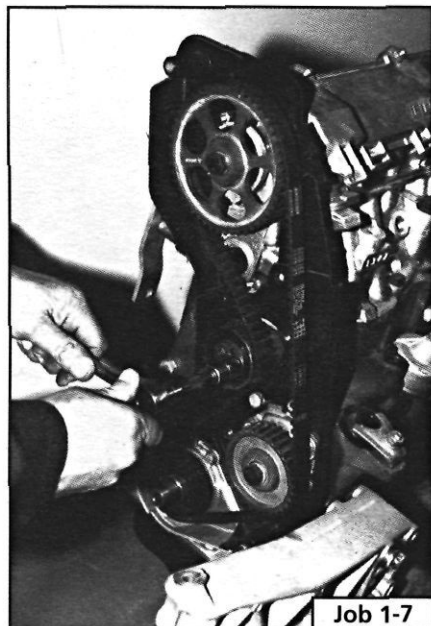

• **Step 7:** Slacken off the belt tensioner...

• **Step 8:** ...and remove the camshaft timing belt.

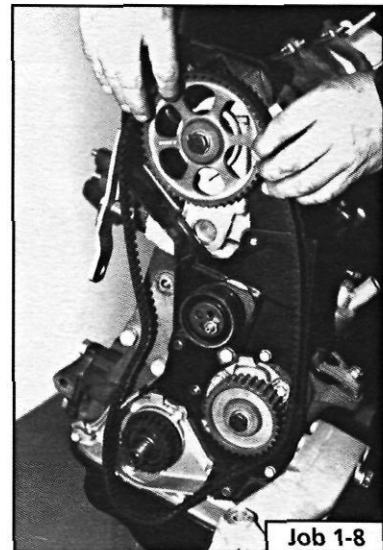

• **Step 9:** The new belt must be fitted with the arrows, printed on the outside of the belt, pointing in the direction of engine rotation. Ensure that the timing marks are still aligned.

L) Step 10: Engage the belt with the crankshaft sprocket first, then in turn, the auxiliary and camshaft sprockets. Finally, feed it round the tensioner pulley. Also, as a double-check that the belt is not 'out', ensure that the yellow lines on the belt align exactly with the timing marks on the camshaft sprocket and crankshaft sprocket.

LJ Step 11: Slacken the tensioner nut and push the pulley onto the belt until taut. Check that the timing marks are still correctly aligned. Still pressing the pulley against the belt, tighten its locking nut.

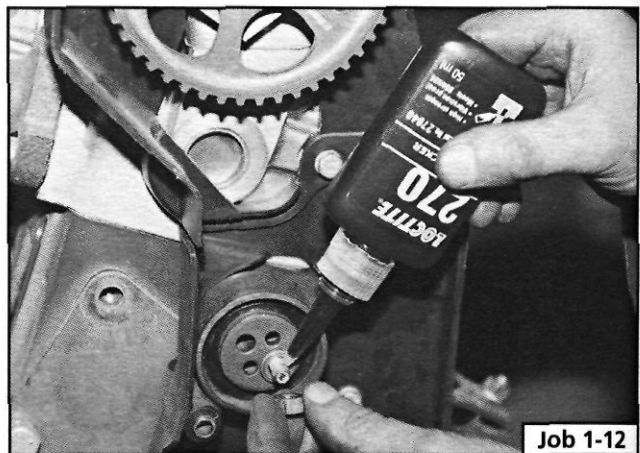

• **Step 12: B INSIDE INFORMATION!** Before finally tightening the tensioner nut when adjusting the tension, remove it, clean the thread and apply Loctite Threadlocker to help stop the nut and washer shaking loose. **Q**

Q Step 13: Turn the engine through two complete turns clockwise and re-check the belt tension. Adjust again if necessary.

H INSIDE INFORMATION! Without the special tools used by FIAT, you can make an approximate adjustment by tensioning the belt so that it can be twisted through 90 degrees (one quarter turn) mid way between the camshaft and auxiliary shaft sprockets, using your finger and thumb. If you can't put enough pressure on the belt tensioner with your fingers, push a pair of bolts into the two holes in the tensioner and lever between them to turn the tensioner. **B**

Job 2. Petrol engine. Cylinder head - removal.

Cj Step 1: Take note of the parts shown in this drawing - which is also relevant to several other jobs on Tipo and Tempra petrol engines.

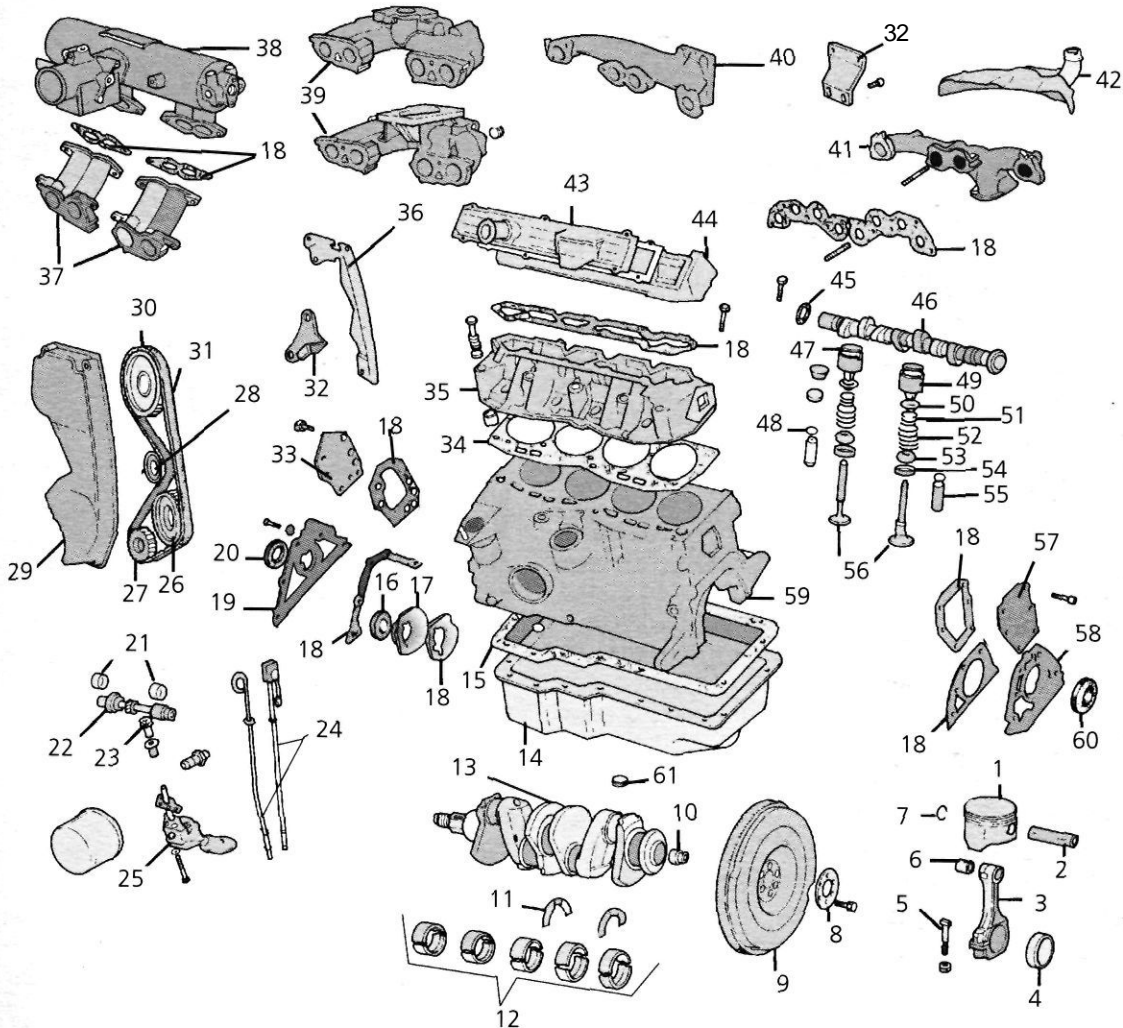

- | | | | | |
|---------------------|-------------------------------|---------------------------------|-----------------------------------|----------------------------|
| 1 - piston | 14 - sump | 27 - crankshaft sprocket | turbo | 51 - valve spring - inner |
| 2 - gudgeon pin | 15 - sump gasket | 28 - tensioner pulley | 40 - exhaust manifold - turbo | 52 - valve spring - outer |
| 3 - connecting rod | 16 - oil seal | 29 - timing belt cover | 41 - exhaust manifold - non-turbo | 53 - valve, top cap |
| 4 - big-end bearing | 17 - auxiliary shaft cover | 30 - camshaft sprocket | 42 - heated air duct | 54 - washer |
| 5 - big-end bolt | 18 - gasket | 31 - camshaft belt | 43 - camshaft cover | 55 - valve guide |
| 6 - small-end bush | 19 - front oil seal housing | 32 - bracket | 44 - camshaft housing | 56 - valve |
| 7 - circlip | 20 - oil seal | 33 - end plate | 45 - oil seal | 57 - end plate |
| 8 - plate | 21 - bush | 34 - cylinder head gasket | 46 - camshaft | 58 - rear oil seal housing |
| 9 - flywheel | 22 - auxiliary shaft | 35 - cylinder head | 47 - tappet shim | 59 - block |
| 10 - spigot bearing | 23 - drive gear | 36 - timing belt - rear cover | 48 - oil seal | 60 - oil seal |
| 11 - thrust bearing | 24 - dipstick | 37 - inlet manifolds - turbo | 49 - tappet body | 61 - sump drain plug |
| 12 - main bearing | 25 - oil pump | 38 - plenum chamber - turbo | 50 - valve, top cap | |
| 13 - crankshaft | 26 - auxiliary shaft sprocket | 39 - inlet manifold - non-turbo | | |

Job 2-1

Q INSIDE INFORMATION! • Before removing the cylinder head, make sure the engine is stone cold.
 • Undo the cylinder head bolts strictly in the order laid out in **Step 18**.
 • These precautions help to prevent cylinder head distortion.
 • The new cylinder head gasket should stay in its packaging until required, to avoid contamination by oil or grease. **Q**

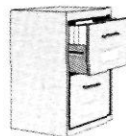

FACT FILE: SPECIAL TOOL PROBLEMS SOLVED!

- It is possible to remove and replace the cylinder head complete with the camshaft housing - but it is very difficult without FIAT's special cranked tool to get round the camshaft housing.
- You CAN undo the bolts with a ring spanner, but you CANT torque them down properly again!
- Because the gasket between the housing and the head could also be suspect, we strongly recommend that you do it 'our' way, by removing the camshaft housing even though you will have to re-set the valve clearances.

SAFETY FIRST!

G Step 2: Disconnect both battery leads, negative terminal first

d Step 3: Drain the cooling system and depressurise the fuel system, if yours is a fuel injection engine - see **PART F: FUELAND EXHAUST.**

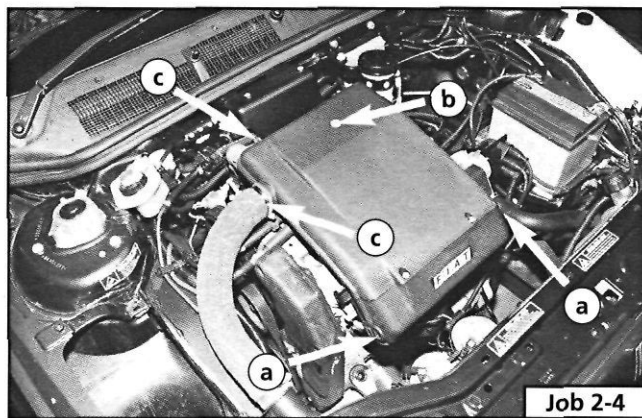

Job 2-4

Q Step 4: Remove the air cleaner by releasing the spring clips (a) at the front of the unit and the screw on the top face (b) and disconnect the hoses <c). Remove the oil vapour recovery pipe clips from beneath the rear of the housing, once it is free to lift up.

CJ Step 5: Disconnect the crankcase vent hose from the cylinder head and the inlet tract or the SPI injector unit, as appropriate and blank off with a bolt of suitable size.

• Step 6A: CARBURETTOR ENGINES.

Disconnect the engine end of the accelerator cable from its idler and the choke cable from its mounting.

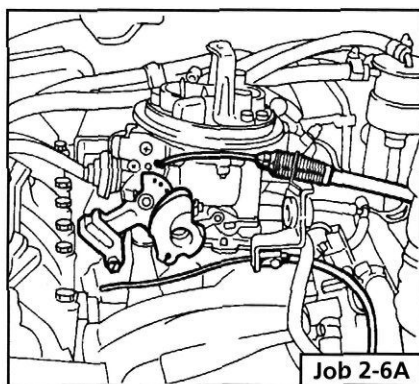

Job 2-6A

• Step 6B: INJECTION ENGINES.

Disconnect the engine end of the accelerator cable fa), the idle speed check actuator (b) and the injector supply (c).

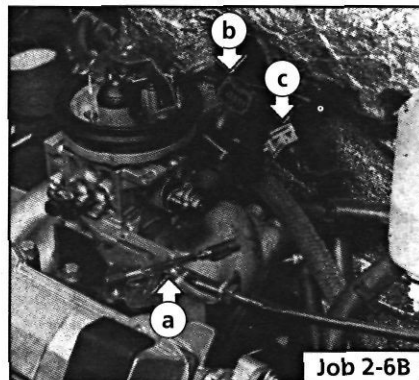

Job 2-6B

• Step 7: Disconnect the electrical leads from the following: the inlet manifold vacuum sensor (arrowed), the manifold coolant temperature sensors (arrowed) and the throttle position switch and any other leads which your engine may have.

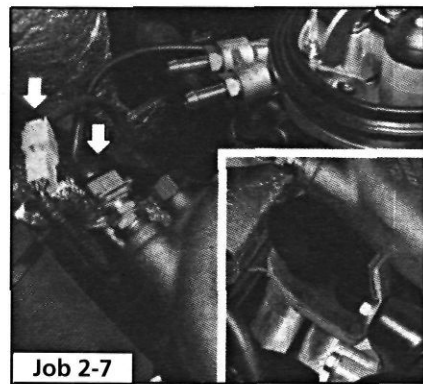

Job 2-7

• Step 8: Detach the exhaust downpipe from the manifold.

d Step 9: Remove the dipstick (arrowed) and the cylinder head coolant temperature sensor (arrowed).

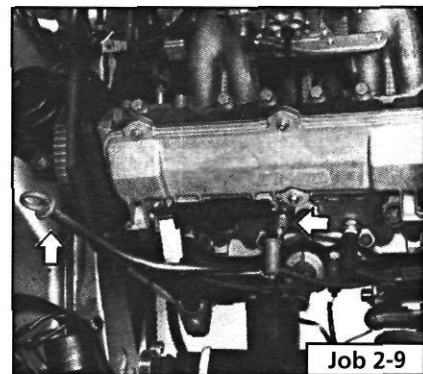

Job 2-9

LJ Step 10: Also remove all the HT leads (along with the distributor cap). Place them to one side.

Q Step 11: Undo the brake servo hose from the manifold.

• Step 12: Remove the water hoses connected to the inlet manifold and thermostat.

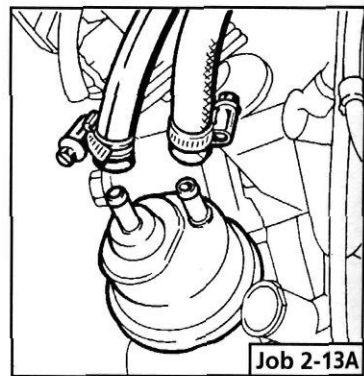

Job 2-13A

J Step 13A: CARBURETTOR ENGINES. Disconnect the fuel pipe from the carburettor and both pipes from the fuel pump. (Label both the pipes and stubs so that they will be reconnected the right way round.)

U Step 13B: INJECTION ENGINES.

Disconnect the fuel supply and return hoses from the injector unit housing (a). Plug the ends.

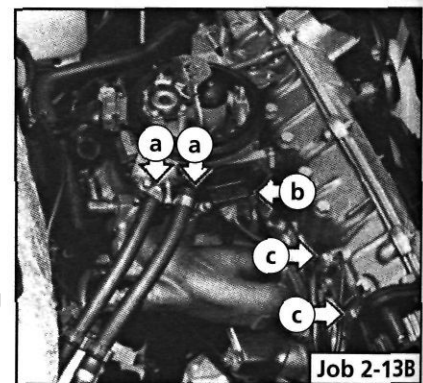

Job 2-13B

• Step 14A: CARBURETTOR ENGINES. Disconnect the distributor vacuum pipe and oil vapour pipes from the carburettor.

• **Step 14B:** INJECTION ENGINES. Disconnect the butterfly valve opening sensor connection (see illustration *Job 2-13B, part b*) and the earth cable (*Job 2-13B, part c*).

• **Step 15:** Remove the timing belt. See *Job 1*.



• **Step 16:** Unbolt and remove the camshaft sprocket. If necessary, use a screwdriver held through the sprocket against a mounting bolt behind it, to stop it from turning.

• **Step 17:** Remove the timing belt tensioner but note that it is in three parts.

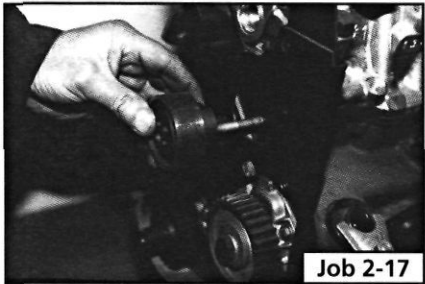

• **step 18:** Unbolt and remove the timing belt backplate. You could leave the bottom half in place, if you are going no further than removing the cylinder head.

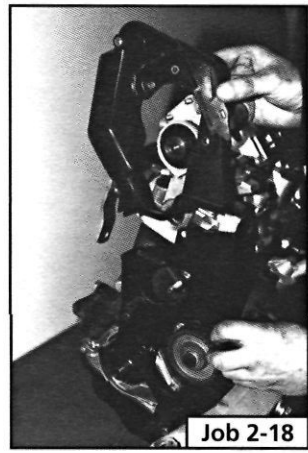

• **step 19:** Take off the six nuts and washers holding the cam cover in place and remove it.

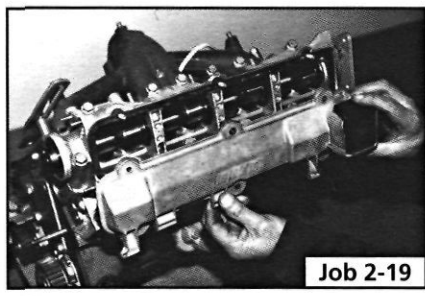

• **Step 20:** The camshaft housing can now be removed in order to access the cylinder head bolts. Slacken the 12 housing bolts progressively, so that no strain is put on the housing through the valve springs.

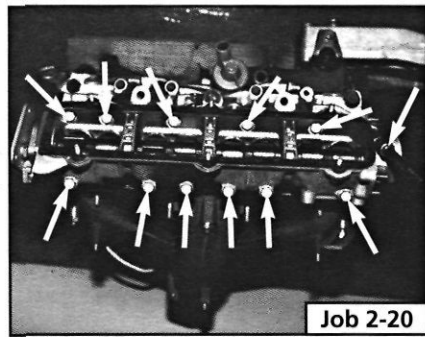

• **step 21:** The camshaft housing can now be lifted away. Note the gasket positioning and fit a new one on reassembly.

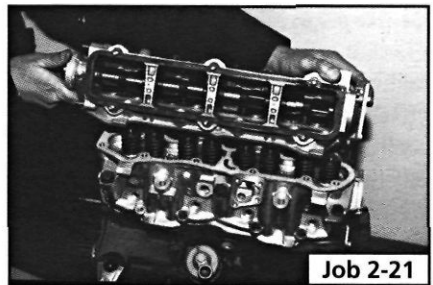

• **Step 22:** Q **INSIDE INFORMATION:** If the cam followers are loose, you may wish to remove them now so that they don't fall out and lose their position. Keep them in the correct order so that they can go back where they came from on reassembly. Q

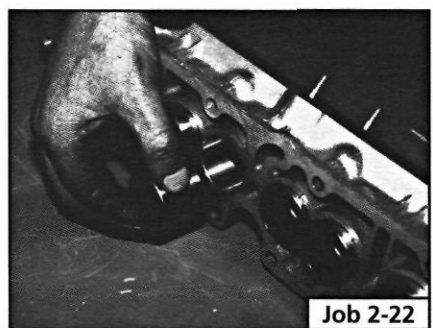

• **Step 23:** Start removing the cylinder head by removing the 4 or 5 small cylinder head bolts (according to model)...

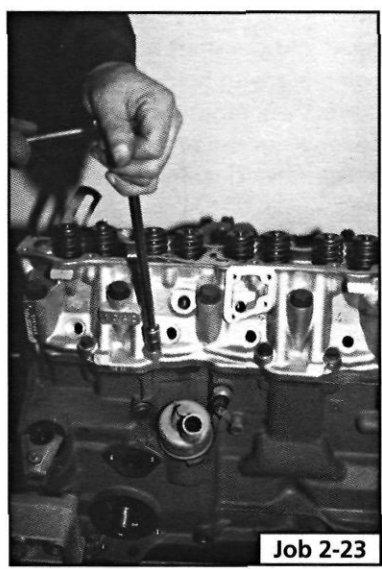

U Step 24: ...numbered 1 to 4 or 5, slackening them in the order shown.

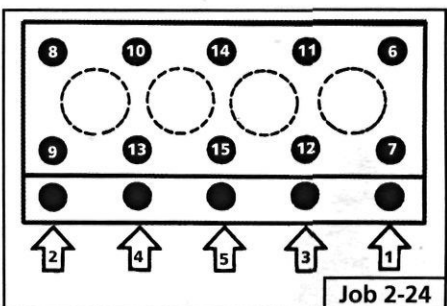

• **Step 25:** Now slacken the remaining 10 bolts half a turn at a time, in the order shown in *Step 24*, until all are loose, and then remove them with their washers.

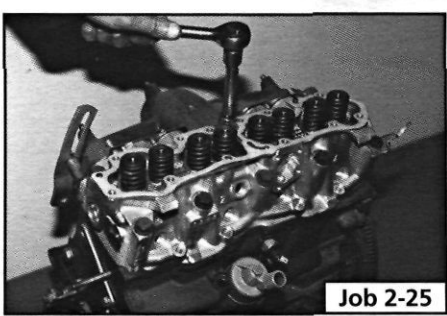

and explosions. Do not allow resin or 2-pack adhesive hardener, or that supplied with filler or 2-pack stopper, to come into contact with skin or eyes. Read carefully the safety notes supplied on the can, tube or packaging and always wear impervious gloves and goggles when working with them.

Fluoroelastomers

Fluoroelastomers are commonly used for oil seals, wiring and cabling, bearing surfaces, gaskets, diaphragms, hoses and 'O' rings. If they are subjected to temperatures greater than 315 degrees C, they will decompose and can be potentially hazardous. Some decomposition may occur at temperatures above 200 degrees C, and it is obvious that when a car has been in a fire or has been dismantled with the assistance of a cutting torch or blow torch, the fluoroelastomers can decompose in the manner indicated above.

According to the Health and Safety Executive, "Skin contact with this liquid or decomposition residues can cause painful and penetrating burns. Permanent irreversible skin and tissue damage can occur". Damage can also be caused to eyes or by the inhalation of fumes created as fluoroelastomers are burned or heated.

After a vehicle has been exposed to fire or high temperatures:

1. Do not touch blackened or charred seals or equipment.
2. Preferably, don't handle parts containing decomposed fluoroelastomers, but if you must, wear goggles and PVC (polyvinyl chloride) or neoprene protective gloves whilst doing so. Never handle such parts unless they are completely cool.
3. Contaminated parts, residues, materials and clothing, including protective clothing and gloves, should be disposed of by an approved contractor to landfill or by incineration according to national or local regulations. Oil seals, gaskets and 'O' rings, along with contaminated material, must not be burned.

WORKSHOP



1. Always have a fire extinguisher of the correct type at arm's length when working on the fuel system. If you do have a fire, DON'T PANIC. Use the extinguisher effectively by directing it at the base of the fire.
2. NEVER use a naked flame anywhere in the workplace.

3. KEEP your inspection lamp well away from any source of petrol (gasoline) such as when disconnecting a carburettor float bowl or fuel line.
4. NEVER use petrol (gasoline) to clean parts. Use paraffin (kerosene), white spirits, or, a proprietary degreaser.
5. NO SMOKING. There's a risk of fire or of transferring dangerous substances to your mouth and, in any case, ash falling into mechanical components is to be avoided.

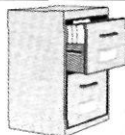

FACT FILE; FOUR WHEEL DRIVE CARS

- Whenever you have to raise a wheel off the ground and turn it by hand, always ensure that the opposite-side's wheel to the one being lifted is also off the ground and free to turn and that both wheels remaining on the ground are held by the parking brake (if possible) and securely chocked in both directions.
- ALWAYS have the gearbox in neutral (or 'N' in the case of automatics). In the case of some 4 wheel drive automatics and those with permanent 4WD, it is necessary to disengage the 4WD system by special means.
- Consult your handbook or seek advice from your main dealer.

6. BE METHODICAL in everything you do, use common sense, and think of safety at all times.

ENVIRONMENT FIRST!

The used oil from the sump of just one car can cover an area of water the size of two football pitches, cutting off the oxygen supply and harming swans, ducks, fish and other river life.

When you drain your engine oil - don't oil the drain!

Pouring oil down the drain will cause pollution. It is also an offense. Don't mix used oil with other materials, such as paint and solvents, because this makes recycling difficult. Take used oil to an oil recycling bank.

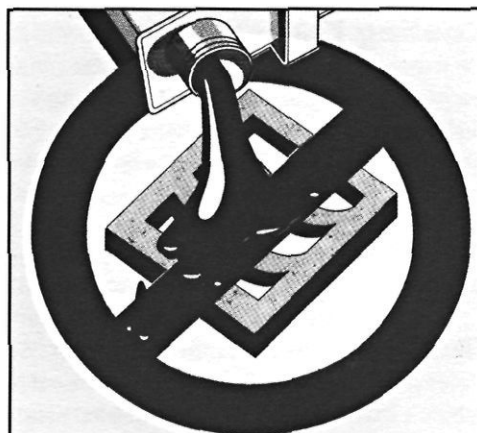

**OH POLLUTES WATER
USE YOUR BRAIN-
NOT THE DRAIN!**

Telephone FREE on 0800 663366 to find the location of your nearest oil bank, or contact your local authority recycling officer.

J Step 26:

Check that nothing remains attached to, or obstructs the cylinder head and lift it clear of the block. If stuck, it is permissible to tap the head

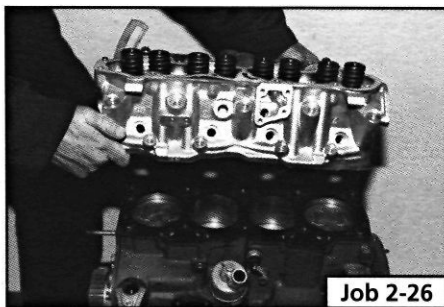

Job 2-26

lightly with a soft mallet to free it. Never use a wedge between the joint faces and remember that the head will not slide off as it is located on dowels.

L Step 27: Remove the old gasket.

Job 3. Petrol engine. Cylinder head and camshaft housing - refitting.

IMPORTANT NOTES: • Here, we show how to refit the head and camshaft housing, separated. The head complete with housing cannot be torqued down correctly without the use of FIAT's special, cranked spanner for use on the semi-hidden head bolts.

• The valve clearances will have to be re-set. See Job 7.

Refer to the illustration to **Job 2-1** in connection with the work described here.

Q INSIDE INFORMATION: FIAT recommend that you should not re-use cylinder head bolts which have been refitted more than three times before. Fit new ones if in doubt, so that you can ensure reliability. **H**

L Step 1: Lubricate the cylinder head bolts and washers and leave them to drain for AT LEAST 20 minutes before fitting them.

Clean the block and cylinder head mating surfaces with a straight edge, taking particular care with the light alloy head. Any gouging of the metal could prove very expensive to have put right!

Make sure that all the holes and coolant passages are clear of any foreign matter, particularly the cylinder head bolt holes which must be clear right down to the bottom.

making it easy!

• Carburettor cleaner - or the purpose-made Loctite 'Chisel' aerosol spray, available from your FIAT dealer, will help to remove pieces of stuck-on gasket.

• **Step 2:** With the block face perfectly clean, remove the cylinder head gasket from its wrapping and, keeping it away from oil or

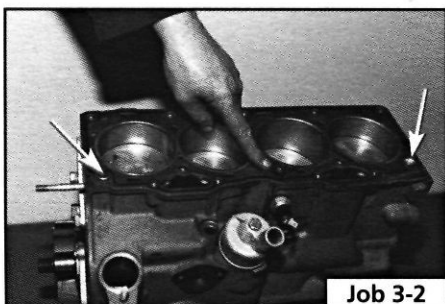

Job 3-2

grease, place it on the block with (on FIAT gaskets) this copper-ringed hole above the correct water passage. The gasket only fits correctly one way round.

IJ Step 3:

Lower the cylinder head into position and locate it on the two dowels (see illustration **Job 3-2**, arrowed).

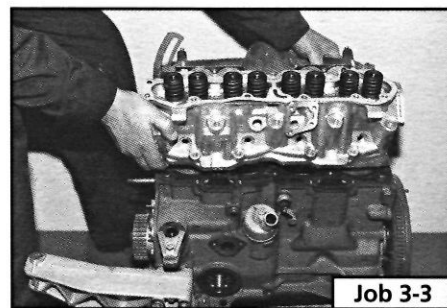

Job 3-3

• **Step 4:** The 10 main cylinder head securing bolts and washers can now be screwed in by hand. Don't fit the smaller ones (arrowed) yet.

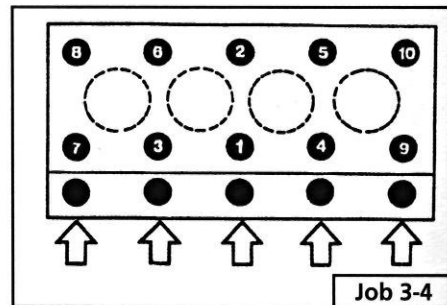

Job 3-4

UI Step 5A: Tighten the 10 larger bolts in their correct sequence as shown in illustration **Job 3-4**. All of the settings are shown in *Chapter 3, Facts and Figures*.

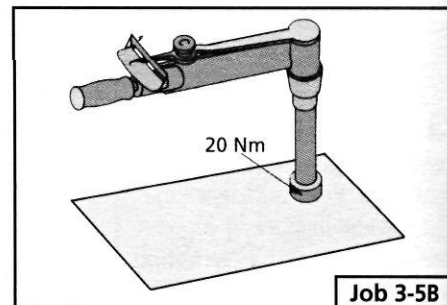

Job 3-5B

• **Step 5B:** Tighten the head down to the first torque setting, following the correct tightening order.

U Step 5C: In the same order, tighten the bolts to their second torque setting.

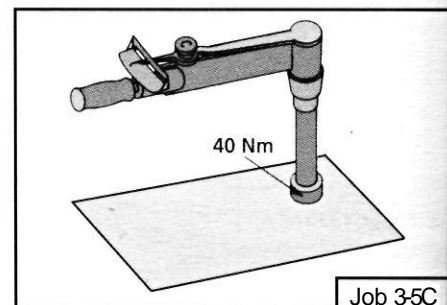

Job 3-5C

• **Step 5D:** Tighten each bolt, once again in the correct order, by a further 90 degrees. You could use an angle gauge (available from auto-accessory stores) in order to be precise.

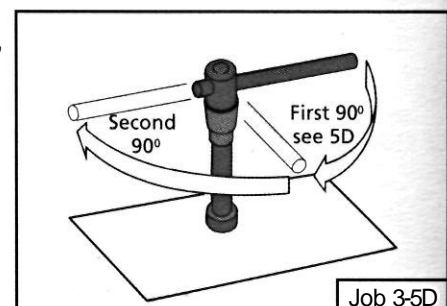

Job 3-5D

Tighten by another (second) 90 degrees, bolt-by-bolt, again in the correct order.

LJ Step 6: Fit the four or five smaller bolts, according to model (see illustration *Job 3-4*, arrowed) close to the spark plug holes, and tighten to their specified torque. See *Chapter 3, Facts and Figures*.

LJ Step 7: All items previously removed in *Job 2* can now be fitted in reverse order. When connecting the exhaust always use a new flange gasket.

LJ Step 8: Ensure that all connections are sound and secure.

LJ Step 9: All items previously removed in *Job 2* can now be fitted in reverse order. Refer to *Job 1* when fitting the timing belt. When connecting the exhaust always use a new flange gasket.

LJ Step 10: Ensure that all connections are sound and secure.

LJ Step 11: Top up the cooling system with the correct 50/50 solution of FL 'Tutela' anti-freeze solution. Check the oil level.

LJ Step 5: Clean and check all components for wear and signs of 'scuffing'.

Q INSIDE INFORMATION! If the camshaft is changed, the followers should be changed as well. If the bores in the housing have 'picked up', these cannot be machined and the housing should be replaced together with new cam followers. B

LJ Step 6: Refit the camshaft to the cam housing and insert the cam followers and shims in their correct bores, using grease to keep them in place. For adjustment of valve clearances see *Job 7*.

making it easy! • When re-inserting the camshaft, it can be difficult to get the camshaft fully in to its end seal. DON'T try hammering it in • all you'll do is damage the seal. Lubricate the seal with fresh engine oil, insert the camshaft until it is aligned with and just touching the seal. Push the camshaft with a twisting motion until it eases its way into the seal.

Job 4. Petrol engine. Cylinder head - dismantling and overhauling.

Refer to the illustration *Job 2-1* for the components covered in this Job.

LJ Step 1: Remove the camshaft housing from the cylinder head. See *Job 2*.

Q Step 2: Remove the camshaft housing end plate (or the distributor mounted in the same place on certain models).

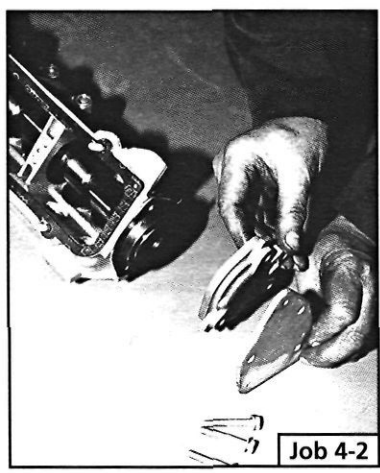

Job 4-2

G Step 3: Remove the cam followers and shims from the housing, keeping them in the correct order for refitting in the same positions.

• Step 4: Slide the camshaft out, taking care not to damage the camshaft bearings with the cam lobes.



Job 4-4

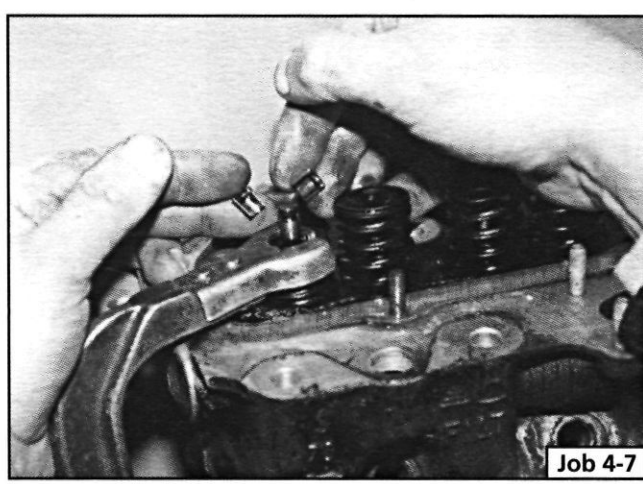

Job 4-7

LJ Step 7: Use a suitable valve spring compressor to compress each spring in turn to allow the removal of the split collets from the valve stems. Inexpensive valve spring compressors are readily available from auto, accessory stores.

Take care not to lose the collets when releasing the spring compressor.

• Step 8: These are the items to be removed once the valve is withdrawn.

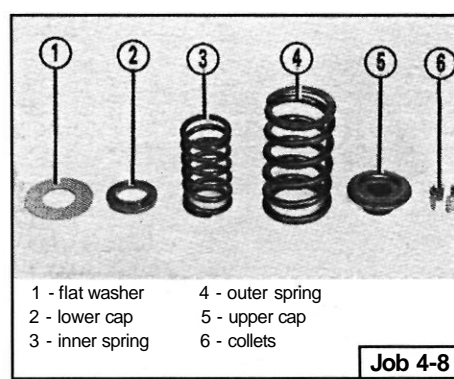

Job 4-8

LJ Step 9: The valve spring caps, springs and spring seats can all be lifted clear and the valves withdrawn from their guides.

making it easy!

• **LJ Step 10:** The valves should slide freely out of their guides. Any resistance may be caused by a build up of carbon, or a slight burr on the stem where the collets engage. This can usually be removed by careful use of fine wet-or-dry paper, allowing you to withdraw the valves without scoring their guides. Keep the valves in their correct order by wrapping a numbered piece of masking tape around each stem.

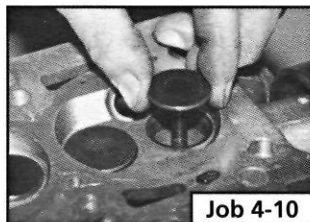

Job 4-10

LJ Step 11: The cylinder head is made of light alloy and is easily damaged when being cleaned. Use a rotary wire brush for the combustion chambers and ports, but no sharp objects such as screwdrivers should be used. The machined surfaces must have all traces of old gasket removed by use of a straight edge. Then wash down with paraffin to remove old oil and dirt and dry with clean rag. At all costs, avoid gouging the cylinder head. This can be very expensive to have put right.

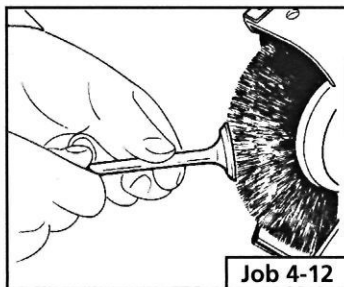

Job 4-12

• **Step 12:** Clean the carbon from the valves with a rotary wire brush and wash them in paraffin. Wash the valve springs, caps, seats and collets and dry.

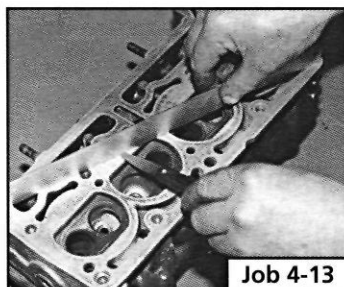

Job 4-13

LJ Step 13: The cylinder head can be checked for distortion by use of a straight edge and feeler gauge. At the same time check for excessive corrosion. If you are in doubt, or if the old gasket had blown, have the cylinder head refaced by your FIAT agent or engine specialist. The valves should be checked for side movement in their guides. Anything but the very slightest tells you that the valve guides are in need of replacement. Your local FIAT agent or engine specialist should do this job. Examine the valve seats for pitting or burning, also check their mating seats in the cylinder

making it easy!

• Before grinding-in the valves, clean the tops of the valve heads back to shiny metal. Now the sucker on the end of your valve grinding stick won't keep falling off when you grind-in the valves!

head. Don't hesitate to seek the advice of your local agent if you have any doubts.

LJ Step 14: Examine the valve seats for pitting or burning. Also, check the valve seats in the cylinder head. Small pits can be removed by grinding the valves onto their seats. The seats in the cylinder head will have to be recut (again, by your local FIAT agent if the pitting is too deep), and new valves fitted.

Q INSIDE INFORMATION! These cylinder heads use hardened valves and seats for use with unleaded petrol. We advise you to consult your FIAT agent or engine specialist for machining if anything other than light valve grinding is required. Q

FACT FILE: VALVE GRINDING

LJ Step 15: Apply a small quantity of coarse grinding paste evenly round the valve seat. A valve grinding stick with a suction pad slightly smaller than the valve head should

be selected. Put a dab of moisture onto the suction pad and press the grinding stick to the first valve.

LJ Step 16: Lower the valve stem into its guide and, holding the grinding stick between the palms of your hands, rub your hands together (like a bushman making a fire), rotating the valve and grinding the two seats together.

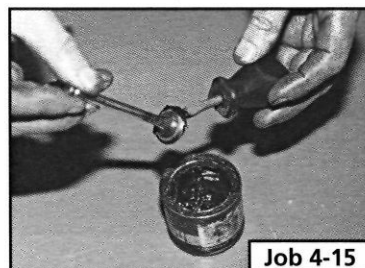

Job 4-15

Lift the valve regularly, say every ten or so turns, to allow the grinding paste to be redistributed. When you can feel the paste wearing smooth, remove the valve and wipe all the surfaces clean. A complete ring of grey contact area should be visible on the valve head and its seat in the cylinder head. If necessary, start off with coarse paste to remove the deeper pits, and finally use fine paste to obtain a smooth finish.

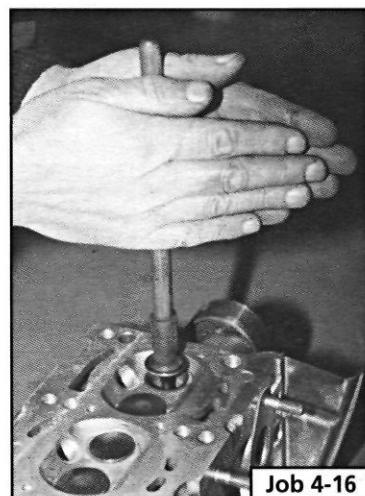

Job 4-16

- Make sure that no paste is allowed to enter the guide. This would cause a lot of wear to the valve stem and guide.
- A narrow contact band means more seat pressure and longer life. A wide band allows rapid valve burning.
- A complete ring of grey contact area should be visible on the valve head and its seat in the cylinder head.
- If necessary, start off with coarse paste to remove the deeper pits, and finally use fine paste to obtain a smooth finish.
- If pitting is too bad, you could have the valve face and the valve seats resurfaced or, in worst cases, the valve and/or valve seat (in the cylinder head) will have to be replaced.
- Consult your FIAT dealer or engine specialist if in doubt.

G Step 17: Now repeat this operation on the remaining valves.

Q Step 18: Wash the whole cylinder head again using paraffin and an old brush, making sure that all traces of grinding paste are removed, then dry off. Use compressed air if available.

SAFETY FIRST!

- Treat compressed air with respect. Always wear goggles to protect your eyes.
- Never allow the airline nozzle near any of the body apertures.

B INSIDE INFORMATION! Check the height of the valve springs against new ones if possible, but if not, compare them with each other. If any are shorter than the others, play safe and replace the complete set. They are bound to have suffered fatigue which could cause premature valve failure. **Q**

G Step 19: To install the valves, start from one end. Lubricate a valve stem with fresh engine oil and slide it in to its guide.

G Step 20: Locate a new valve stem seal over the stem of the valve (if applicable) and push down into contact with the guide. Position the seal on its seat using a suitable metal tube.

G Step 21: Refit the flat washer and spring seat.

G Step 22: Position the inner and outer springs and the spring cap.

G Step 23: Re-apply the valve spring compressor and compress the springs enough to allow you to engage the split collets in the stem grooves.

D INSIDE INFORMATION! Grease the grooves so that the collets will 'stick' in place. The collets are easily fitted by 'sticking' the backs of them onto the end of a screw-driver with some grease and feeding them into position, **f**

G Step 24: Carefully release the spring compressor and check that the collets are correctly located. Tap the end of the stem with a hammer, to bed them in.

G Step 25: Fit the remaining valves.

Job 5. Petrol engine - dismantling.

G Step 1: Familiarise yourself with the layout of the engine. Refer to illustration **Job 2-1** for an exploded view of the engine components.

U Step 2: Drain the engine oil. Remove the cylinder head. See **Job 2**.

G Step 3: Remove the distributor. See **PART D: IGNITION**.

• **Step 4:** Remove the petrol pump and spacer block, if the mechanical type (a). (Electric fuel pumps are in the fuel tank.)

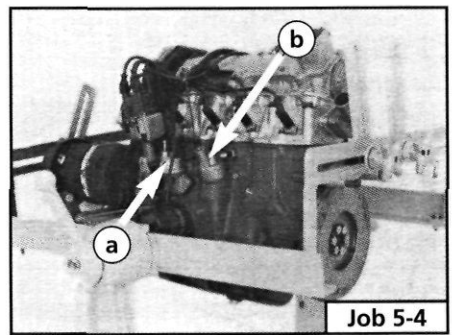

Job 5-4

• **Step 5:** Remove and discard the oil filter and remove the crankcase breather (see illustration **Job 5-4, part b**) with its pipe.

IJ Step 6: Remove the water pump complete with its distribution pipe, and the power steering pump (if fitted).

Q Step 7: Remove the alternator, the crankshaft pulley, the crankshaft and camshaft sprockets, the cam belt tensioner and the cam belt cover backplate.

• **Step 8:** Remove the auxiliary shaft sprocket...

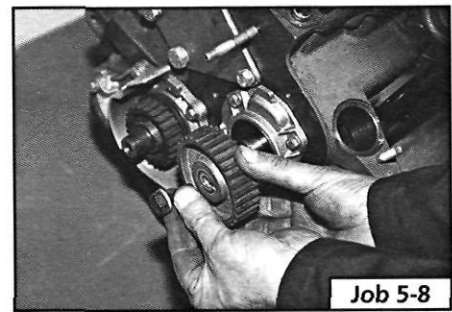

Job 5-8

• **Step 9:** ...the end plate and seal, and remove the auxiliary shaft.

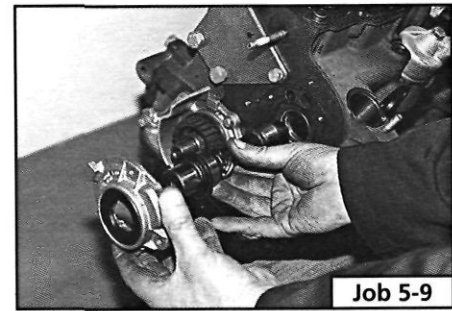

Job 5-9

• **Step 10:** Undo and remove the clutch, and then the flywheel.



Job 5-10

• **Step 11:** Turn the engine assembly over and remove the sump.

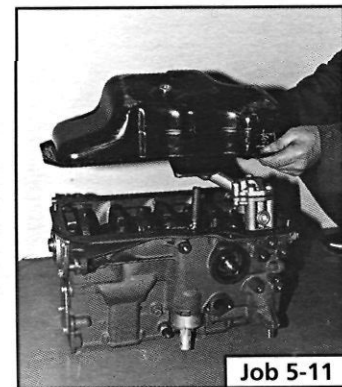

Job 5-11

• **Step 12:** Take off the oil pump (the three larger bolts)...

LJ Step 13: ...and the return pipe.

Q Step 14: Undo and remove the front crankshaft seal carrier (5 bolts)...



Job 5-12



Job 5-13

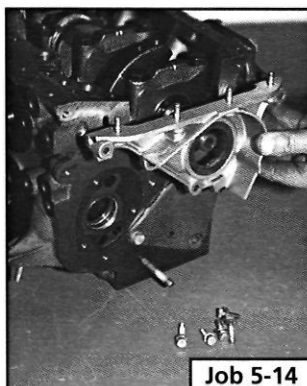

Job 5-14

• **Step 15:** ...and the rear crankshaft seal carrier (6 bolts).

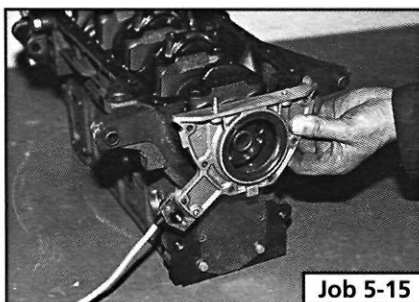

Job 5-15

• **Step 16:** Check that all the connecting rods and their big-end bearing caps are marked with matching numbers, starting from the timing cover end. Make sure that the markings tell you which way round they go! If not, add your own marks with a centre punch before removing.

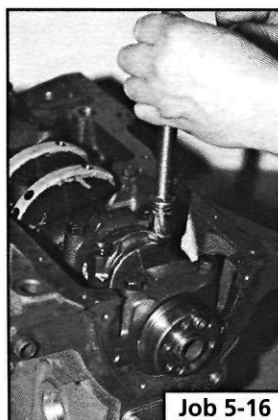

Job 5-16

• **Step 17:** Undo the securing bolts and remove the caps, keeping them in their correct order.

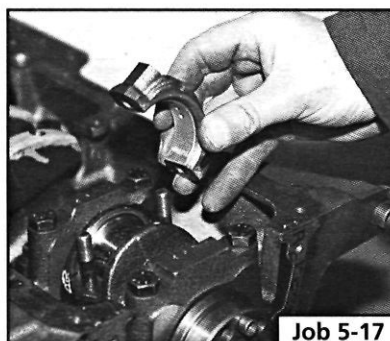

Job 5-17

making it easy!

• **Step 18:** Use a hammer handle and tap

*the piston!
connectingrod
assemblies
carefully up
and out of the
bores...*



Job 5-18

• **Step 19:** ...keeping them in the correct order and the matching conrods and bearing caps together.



Job 5-19

making it easy!

• • **Step 20:** Bearing shells are best removed by sliding them out, pushing the tab-end out first.

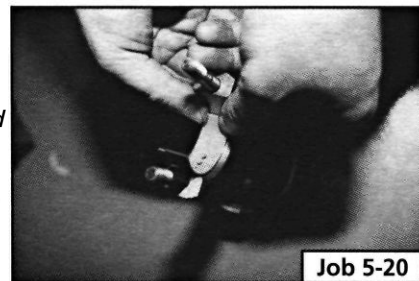

Job 5-20

• **Step 21:** Check that the five crankshaft main bearing caps are correctly marked, starting from the timing cover end.

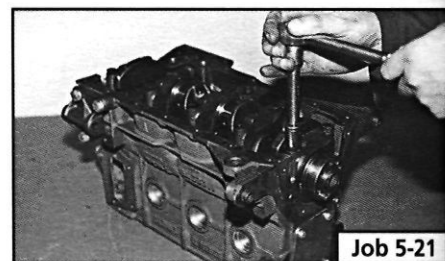

Job 5-21

• **Step 22:** Undo and remove them, keeping them in order.

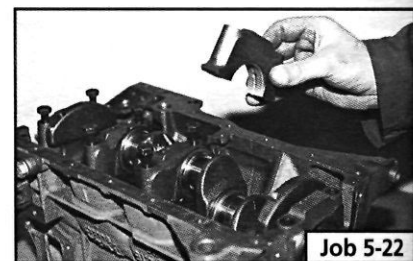

Job 5-22

• **Step 23:** Lift the crankshaft clear of the cylinder block.

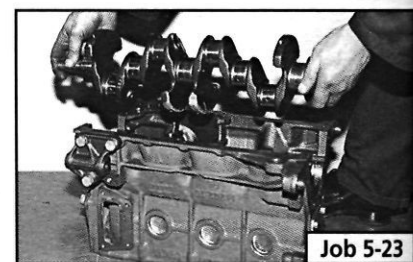

Job 5-23

• **Step 24:**

Remember to retrieve the two thrust washers from the end main bearing in the block. There are none in the cap.

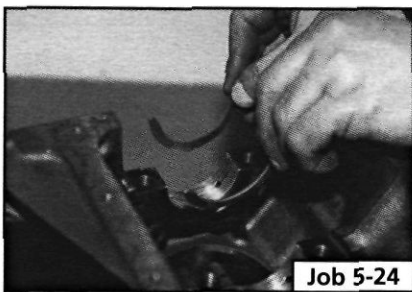

If so, you will probably need a new housing. If you are replacing the camshaft, fit new followers as well.

IMPORTANT NOTE: All bearings, shells, piston rings and ALL seals that bear on moving parts MUST be copiously lubricated with fresh engine oil as the engine is being reassembled. Work ONLY in clean conditions, with clean components and clean hands. Re-assemble in the reverse order of the dismantling procedure and take note of the following steps which will help you carry out a smooth operation.

Job 6. Petrol engine - checking and reassembly.

D INSIDE INFORMATION: It is good policy to change the oil pump when carrying out an engine overhaul. A replacement engine supplied by your FIAT agent would include a new pump. Q

Checking for Wear

GENERAL

All parts must be thoroughly cleaned for inspection - still! keeping them in the right order for reassembly in case they are to be re used. Check each component as follows:

CYLINDER BLOCK

Look for any cracks in the casting, particularly at bolt holes and between cylinders. Check the bores for score marks, caused by burned pistons or broken rings. Check for a wear ridge just below the top of the bore where the top piston ring ends its travel. If any of these defects are present in any of the cylinders, they will have to be rebored. Ask your FIAT dealer or engine specialist to inspect and measure the bores for wear if you are unsure. It is sometimes possible to 'glaze bust' the bores and fit new piston rings, assuming the pistons and bores to be in reasonable condition. All of this work can be carried out by your FIAT dealer.

CRANKSHAFT

Check all the mains journals and crankpins for any signs of wear ridges round the circumference or scoring of the surface. Check for ovality with a suitable micrometer, 0.005 mm being the maximum permissible amount. Check the shell bearings, which should have an even, dull grey finish. If this has worn through to the copper coloured backing, or if the crankshaft has any of the previously mentioned faults, the crankshaft should be reground by your specialist who will also supply the new shell bearings and thrust washers.

Check the crankshaft end float by using a feeler gauge between the thrust washer and the crankshaft. Thicker washers are available if required, see *Chapter 3, Facts and Figures*.

CAMSHAFT

Check each cam lobe for wear, which can be quite rapid once started. The cam followers should also be checked, particularly where they contact the cam lobe. Check the five camshaft bearings and their corresponding surfaces in the housing for a smooth shiny surface without wear ridges. Check the cam follower bores in the camshaft housing for pitting or scoring.

Engine Reassembly

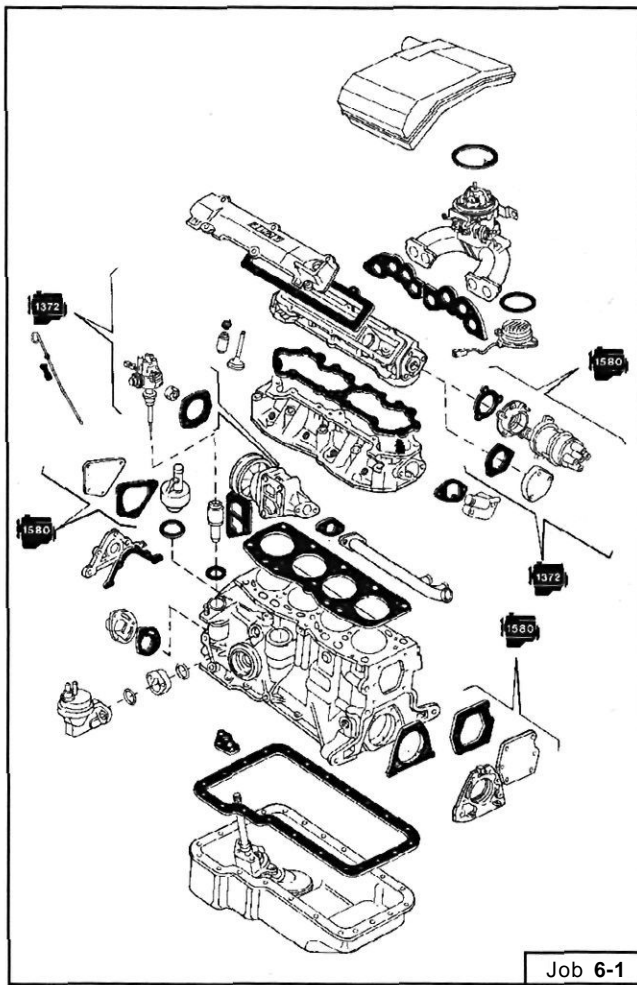

[J] **Step 1:** Make sure you have all the necessary gaskets, available from your FIAT dealership.

CRANKSHAFT

Q Step 2: Apply some grease to the smooth side of the thrust washers and 'stick' them in position either side of No. 1 main bearing.



ENGINE REPAIR

d Step 3: Make sure the bearing seats in the block are perfectly clean and locate the shells so that their tabs engage with the slots. Lubricate the shells liberally with fresh engine oil and lower the crankshaft into position.

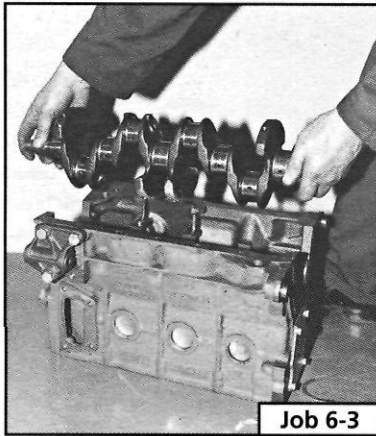

Job 6-3

Q Step 4: Fit the remaining halves of the shells into the bearing caps, lubricate them and position the caps the right way round and in the correct order.

LJ Step 5: Screw the bolts in finger tight and check that the crankshaft rotates freely and smoothly.

LJ Step 6: Tighten the bolts evenly and progressively until the specified torque setting is reached. See **Chapter 3, Facts and Figures**. Check again that the crankshaft rotates smoothly.

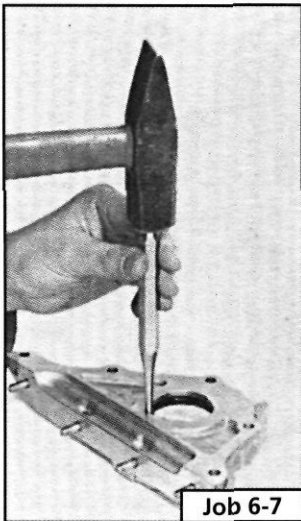

Job 6-7

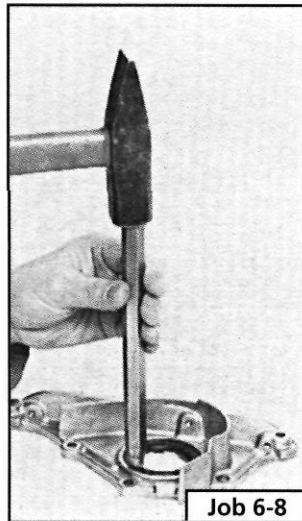

Job 6-8

Q Step 7: Using a suitable screwdriver, prise out the old oil seal from the front housing or drift it out, as shown.

Q Step 8: Clean the oil seal recess in the housing and drive the new seal into position, preferably using a suitably sized socket - the lip of the seal facing in towards the block. Lubricate the seal with copious amounts of fresh engine oil.

Q Step 9: Refit the housing with a new gasket and make sure that the housing face is flush with the face of the cylinder block by using a straight edge across the surfaces, then tighten the bolts.

Q Step 10: Take the rear oil seal housing and repeat **Step 7** to **Step 9**.

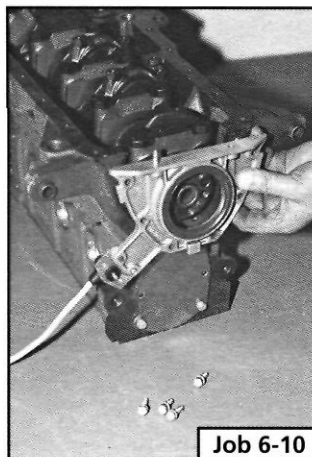

Job 6-10

PISTON/CONNECTING ROD ASSEMBLIES

• Step 11: Fitting the gudgeon pin in connecting rod - piston assembly.

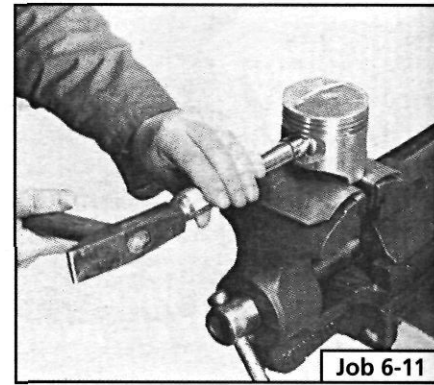

Job 6-11

Fit the piston in the connecting rod, positioning it so that the flat part of the crown is facing the same way as the cylinder bore number on the connecting rod. See **Step 12**.

Fit new circlips to the ends of the gudgeon pins.

• Step 12: Note the correct piston offset relative to the auxiliary shaft (1). Note the positions of the con-rod cylinder bore numbers (2).

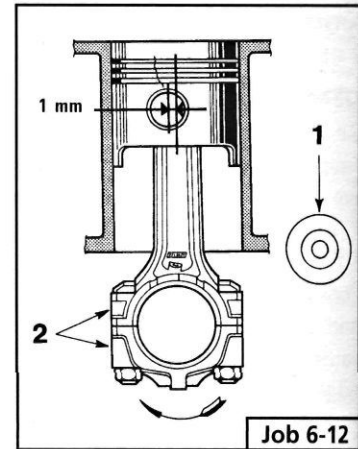

Job 6-12

• Step 13A: Make sure the bores and pistons are clean. Position the piston ring gaps at equal intervals round the pistons circumference and lubricate well. Make sure the rings are fitted with the word 'TOP' facing upwards where marked.



Job 6-13A

• Step 13B: Alternatively, use a special piston ring fitting tool, if you have one - or have your dealer do it for you.

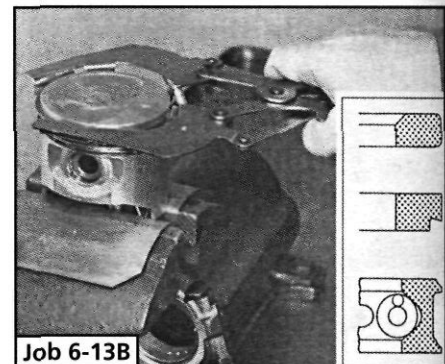

Job 6-13B

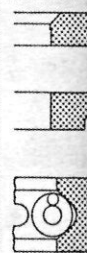

• **Step 14:** Locate a ring clamp over the piston rings and tighten enough to close the ring gaps, but not too tight! Lubricate the rings so that they compress and slide easily within the damp.



Job 6-15

• **Step 15:** With the ring damp touching the cylinder block, use a hammer shaft to carefully tap the piston through the damp and into the bore.

• **Step 16:** Locate the upper half of the big end shell bearing in the conrod, making sure that the mating surfaces are clean. Lubricate the crankpin and the big-end shell and draw the conrod down the bore so that the big end locates with the crankpin.

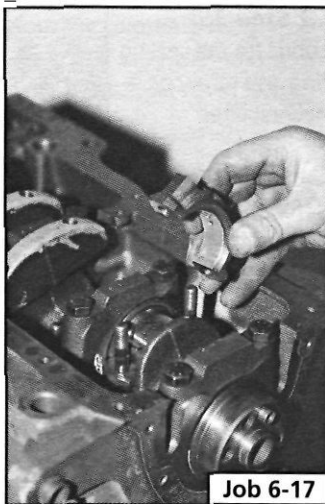

Job 6-17

• **Step 17:** Fit the other half of the big-end shell to the bearing cap and lubricate. Offer the cap to the connecting rod and make sure that the numbers match. Screw in the fixing bolts and tighten progressively to the correct torque. See Chapter 3, *Facts and Figures*.

• **Step 18:** Fit the remaining piston/conrod assemblies and stand the engine upside down on a clean surface.

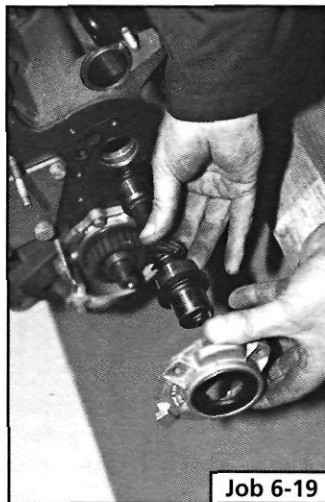

Job 6-19

• **Step 19:** Lubricate the auxiliary shaft bearings and position the shaft in the cylinder block.

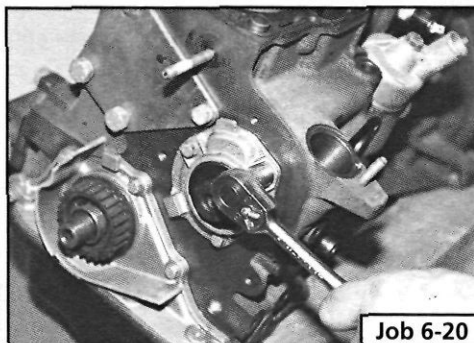

Job 6-20

• **Step 20:** Fit the auxiliary shaft end plate complete with a new seal and gasket.

J Step 21: Prime the oil pump with new oil. Fit the pump and the oil return pipe, tightening the bolts to their specified torque. See

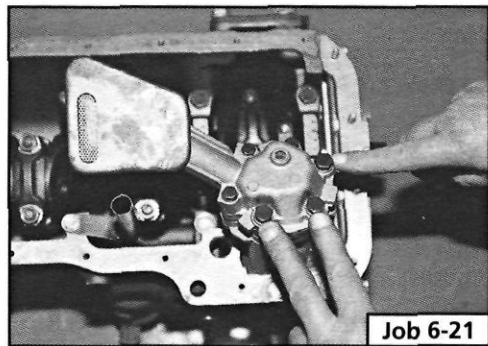

Job 6-21

Chapter 3, *Facts and Figures*. The three larger bolts, shown here, locate the pump to the block.

• **Step 22:** Apply FIAT sealing compound No. 5882442 (or Loctite equivalent) to the joints between the cylinder block and the front and rear oil seal housings.

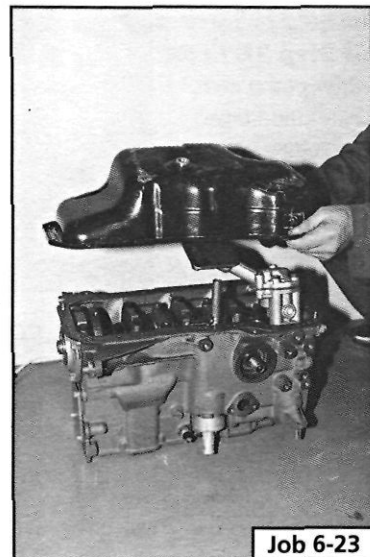

Job 6-23

Q Step 23: Place a new gasket on the cylinder block and fit the sump. Make sure that the securing nuts and bolts have their plates under them and tighten them progressively.

LJ Step 24: Turn the engine over so that it is now standing on its sump.

Q Step 25: Refit the cylinder head, the camshaft housing and camshaft assembly. Refer to **Job 3**.

Q Step 26: Refit the two inner parts of the timing belt cover.

LJ Step 27: Refit the cam belt tensioner and lock, temporarily, in the non-tensioning position.

Q Step 28: Fit the crankshaft, auxiliary and camshaft sprockets, and tighten to their correct torques. See Chapter 3, *Facts and Figures*.

IMPORTANT NOTE: When refitting the crankshaft pulley nut, note that the stepped side must face the engine.

• **Step 29:** Fit the timing belt. See **Job 1**.

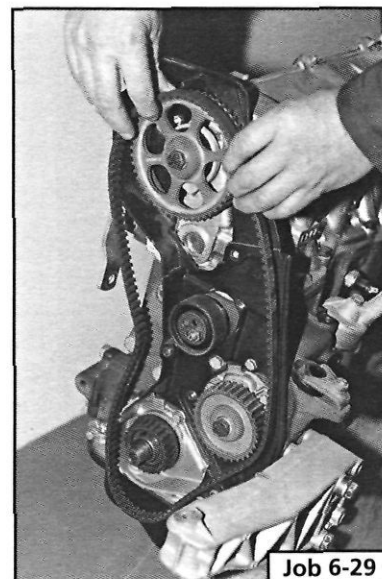

Job 6-29

- **Step 30:** Fit the crankshaft pulley and tighten. See **Chapter 3, Facts and Figures.**

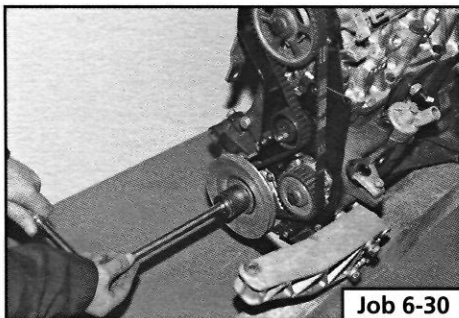

Job 6-30

- **Step 31:** Fit the water pump and distribution pipe.

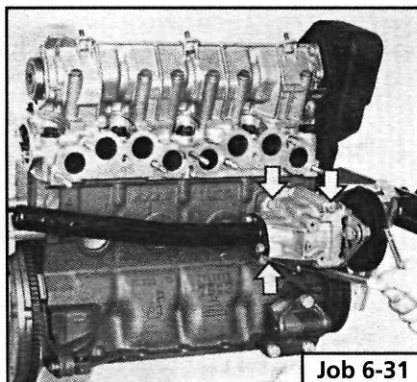

Job 6-31

- **Step 32A:** Refit the flywheel. Do not unbolt the TDC sensor (1) from the oil seal housing at its mounting plate bolts (2) unless it is essential to do so.

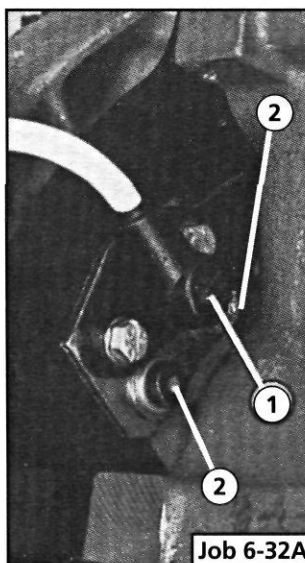

Job 6-32A

- G Step 32B:** If the sensor mounting plate has to be disturbed, you will need the FIAT special tool illustrated here (inset) in order to reposition it correctly. Position the timing mark on the crankshaft pulley with the zero degrees mark on the outer timing belt cover (and double check that the timing mark on the flywheel - rubber bung removed - is aligned at zero degrees).

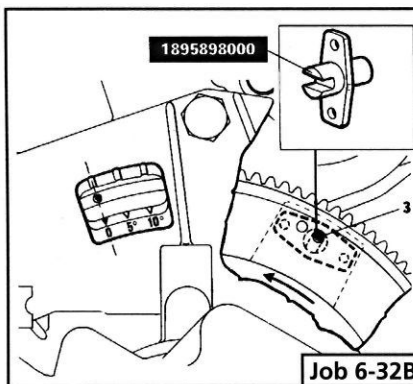

Job 6-32B

With the bracket fitted to the oil seal housing, fit the FIAT special tool onto the bracket in place of the sensor with a slot in the tool fitting exactly over the TDC pin on the flywheel.

When everything is lined up, position the bracket accurately and tighten the bolts. Remove the tool and refit the sensor.

IMPORTANT NOTE: During assembly, a shear-bolt will have been fitted to prevent accidental movement of the bracket. If you need to undo it, you will need to drill it out and you should replace it with a new one obtained from your FIAT dealership.

- **Step 33:** Refit the clutch See **PART B: TRANSMISSION, Job 4.**

LA Step 34: Refit the fuel pump and pushrod using new gaskets on both sides of the spacer block, 0.3 mm thick between the spacer and the engine and 0.7 mm between the spacer and the pump. See **PART F: FUEL AND EXHAUST** for information on setting the pump position.

- U Step 35:** Lubricate the sealing ring and screw on a new oil filter.

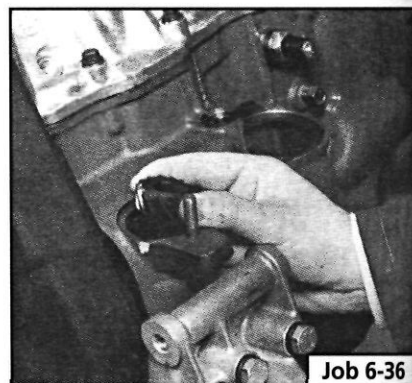

Job 6-36

- **Step 36:** Before refitting the distributor, (see **PART D: IGNITION**) refit, if necessary, the oil pump drive gear.

- **Step 37:** Refit all remaining auxiliary components (including the oil vapour recovery device, shown here), using new gaskets as necessary and referring to **Chapter 3, Facts and Figures** for the torque settings.



Job 6-37

- Q Step 38:** Reconnect the engine to the transmission. See **Job 11.**

- **Step 39:** Refit the complete unit to the car. See **Job 9.**

- **Step 40:** **H INSIDE INFORMATION!** Before fitting the spark plugs and with a fully charged battery, turn the engine on the starter until the oil warning light goes out. This primes the lubrication system and gives more immediate oil pressure on initial start up after overhaul - a critical time in the life of an engine. **Q**

LJ Step 41: Fit the spark plugs and start the engine - this might take a few seconds more than normal on the initial start up.

LJ Step 42: Allow the engine to warm up on fast idle until it reaches working temperature and then slow it down to its normal speed (if adjustable - see **PART F: FUEL AND EXHAUST**)

G Step 43: Stop the engine and allow it to cool, check the oil and coolant levels and look for any leaks.

[1 Step 44: Avoid over-revving or overloading the engine during its settling down period of 600 miles. We recommend an oil and filter change at this mileage - this will help to extend the life of your new engine.

Job 7. Petrol engine. Valve clearances - adjustment.

B INSIDE INFORMATION! Adjustment should always be made with the engine cold. **Q**

U Step 1: Remove the camshaft cover and the spark plugs. Jack up a front wheel and engage top gear. Turning the wheel will rotate the engine and therefore the camshaft. If the engine is out of the car, use a socket and long lever on the crankshaft pulley nut. If the cylinder head is detached, turn the camshaft belt sprocket, by hand.

Q Step 2: The inlet and exhaust valves use different clearances which are checked when each cam lobe is pointing directly away from its follower. See *Chapter 3, Facts and Figures*.

Q Step 3: The order in which the valves are fitted in the cylinder head is:

Inlet: 2-3-6-7

Exhaust: 1-4-5-8

from the timing cover end.

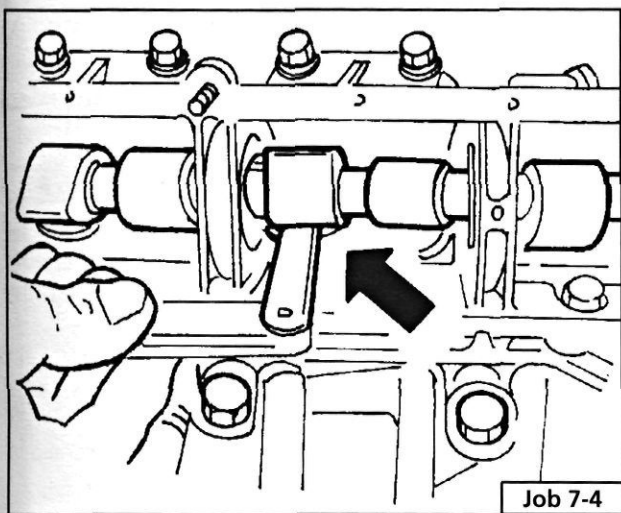

G Step 4: Select a feeler blade which is about the thickness of the correct valve clearance and insert it between the heel of the cam and the cam follower shim when the cam lobe is uppermost. If necessary, select different thicknesses of feeler blade until a small amount of drag can be felt as the blade is pushed in and out. Record the total blade thickness. This is the valve clearance for this valve.

Q Step 5: Rotate the camshaft and repeat this operation on each of the remaining seven valves, noting their respective clearances. Those which have clearances within limits obviously don't need any further attention.

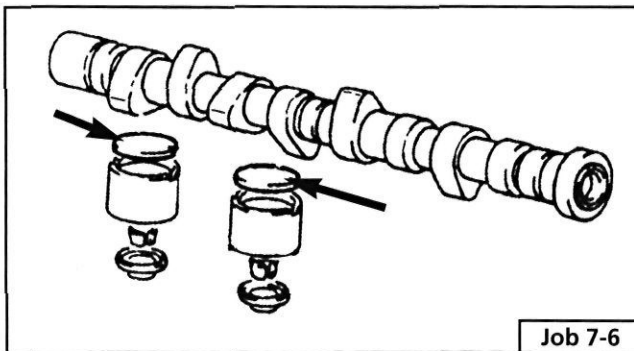

Q Step 6: The remaining valves will now need to have their shims (arrowed) changed for thicker or thinner ones, bringing their clearances to within the specifications shown in *Chapter 3, Facts and Figures*.

Q Step 7: A special tool is needed to depress the cam follower and allow extraction of the shim. This is available from your FIAT dealer, or you will have to make a lever with a fork that locates nicely on the rim of a cam follower allowing removal of the shim by prising it from the follower.

- Step 8:** The thickness of a shim is engraved on it in mm (arrowed). If this is worn away, you will have to measure the thickness with a metric micrometer - or have your FIAT dealer do it for you. Your FIAT dealer can also supply any new thickness of shim you may require.



- Step 9:** Where a clearance is too small with the thinnest shim in position, the valves should be removed and the stem ground just sufficiently to make the correction. Your FIAT dealer can do this, keeping the end square and retaining a smooth finish.

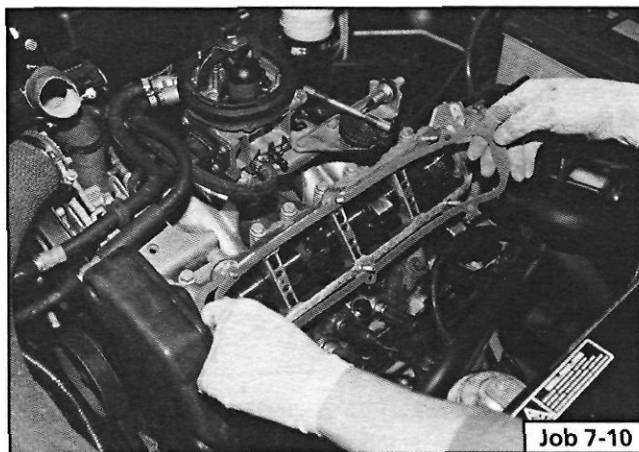

Q Step 10: Be sure to use a new gasket when the cover is replaced.

CHAPTER 2 USING YOUR CAR



We recommend that you read this chapter carefully, so that you will become familiar with your vehicle's controls and instruments.

This Chapter is taken from FIAT's own official Handbooks on the Tipo and Tempra. It contains important and helpful information for the operation of your FIAT Tipo or Tempra.

KEYS AND LOCKS

J 1. DOORS AND BONNET

DOOR LOCKS

Most FIAT Tipos and Tempras have manual locking. You turn the key in the lock in the normal way to lock and unlock the door.

CHILDPROOF LOCKS

1A. Some models are fitted with childproof locks. You will find them in the ends of the rear doors, when open.

- Place your ignition key in notch A, in the end of the door, when open.

- Turn to the right to lock the childproof rear door locks; turn to the left to unlock.

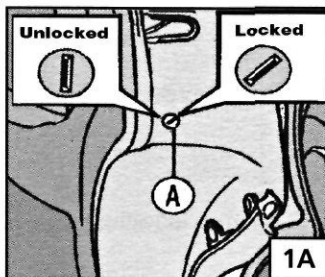

REMOTE LOCKING/UNLOCKING

1B. A directional signal is emitted when you press button A on your remote unit (early models) or on your ignition key (later models).

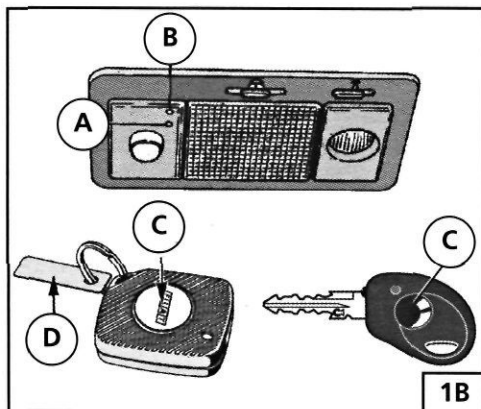

Receiving Unit In Car: The receiving unit can store up to 6 codes. Tag D, supplied with every receiver, has a code number stamped on it. **Keep this tag in a safe place - replacements are very expensive.**

To Store the Code of Your Transmitter:

- Press and hold down button A with a ball-point pen. The red LED B illuminates, indicating that the receiving unit is ready to store the code.
- Hold down button C on your remote unit/ignition key.
- The LED at B turns off, indicating that the receiver has stored the code.
- Release Button A. Red LED B flashes for about 8 seconds to confirm that the code has been stored.

If you press button A again within 8 seconds, the red LED B illuminates indicating that the receiving unit is ready to store another code. Repeat the procedure.

If you lose a remote unit there are two ways to store a new code:

Using a Remote Unit With Code Already Stored:

- Press and hold down button A. After about 2 seconds red LED B flashes once.
- Press button C on the remote whose code has been stored. Red LED B illuminates.
- Release button A. Red LED B flashes for 8 seconds indicating new code has been stored.

Manual Operation: Have tag D ready. The four numbers stamped on the tag will be used in this procedure:

- Press Button A twice. Red LED B flashes 3 times and then turns off for about 2 seconds.
- When LED B lights up again, press button A the number of times indicated by the first code number on tag D (if 0 do not press the button). Two seconds after pressing button A, LED B will turn off for 2 seconds.

IMPORTANT NOTE: The presence of dirt, snow or ice on the side windows may prevent operation.

Job 8. Petrol engine/transmission - removal.

IMPORTANT NOTE: See **PART B: TRANSMISSION** for gearbox removal by itself.

B INSIDE INFORMATION! The complete engine/transmission unit is removed and replaced from under the car - and this applies to all types. Make sure you can raise the front of the car high enough (and support it safely and securely!) to allow the power unit to be pulled clear from underneath, before starting work! Q

• **Step 1:** Remove the bonnet - see **PART I: BODY AND INTERIOR, Job 1.**

• **Step 5:** Disconnect the carburettor or injector fuel lines, choke and throttle cables and hoses and electrical connections (arrowed).

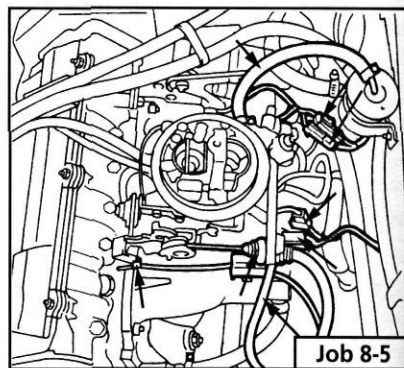

LJ Step 6: Disconnect the starter motor cables, HT leads, fuel pump lines, sensors and electrical connectors arrowed.

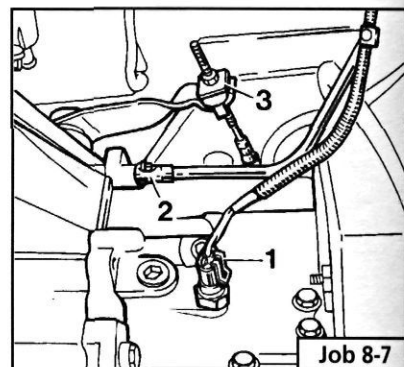
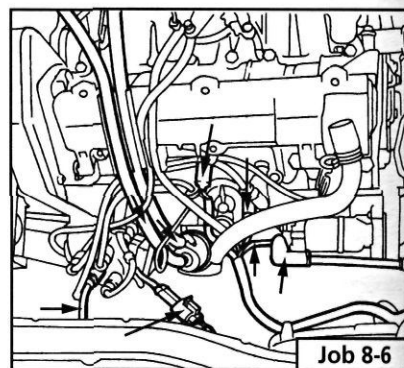
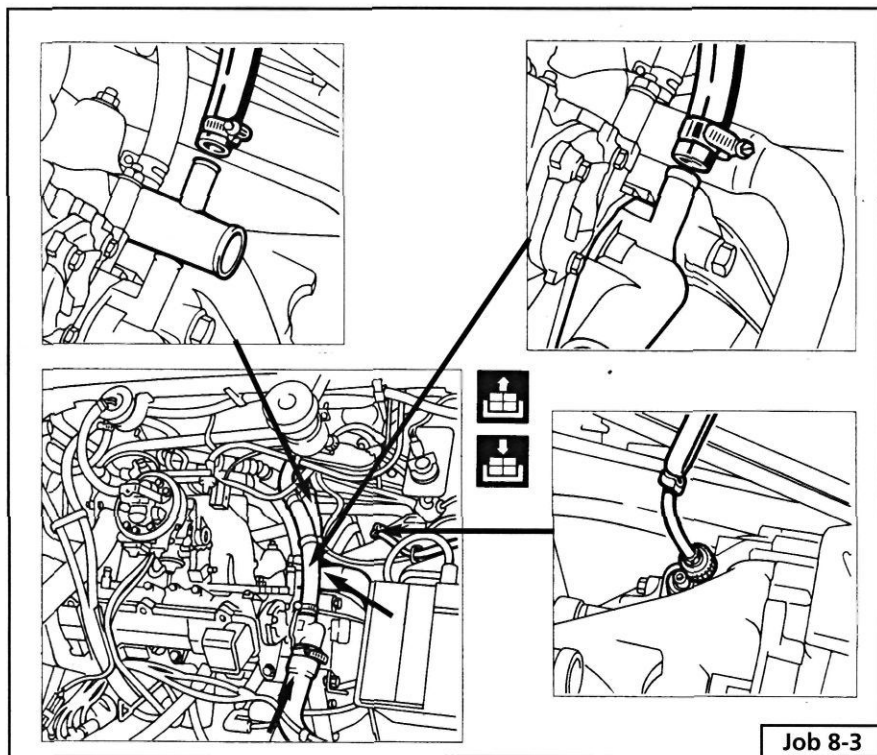

□ **Step 2:** Disconnect the battery earth lead.

Q **Step 3:** Drain the cooling system and the engine oil. Disconnect all hoses shown.

• **Step 4:** Remove the air filter-to-engine connections - earlier type illustrated. (There are some hose connections underneath on the later type, mounted on top of the engine.) Disconnect the electrical connection and all other hoses from the filter housing.

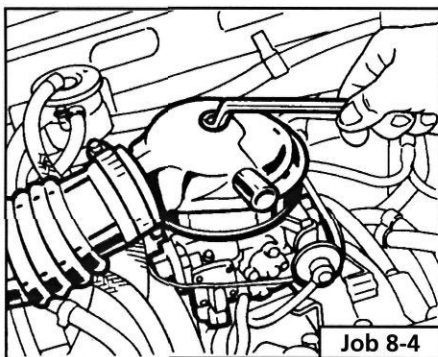

L) **Step 7:** Disconnect the clutch cable (3) or clutch slave cylinder, if hydraulic, the earth cable (2) and the reversing lights switch cable (1) from the top of the gearbox.

d **Step 8:** Disconnect the alternator cables.

C.) **Step 9:** Slacken the front wheel bolts, raise the car and support securely on axle stands. Remove the wheels.

• **Step 10:** Drain the gearbox oil.

J **Step 11:** Remove the buttons (gearbox side, arrowed) fixing the dust shield to the wheel arch on each side.

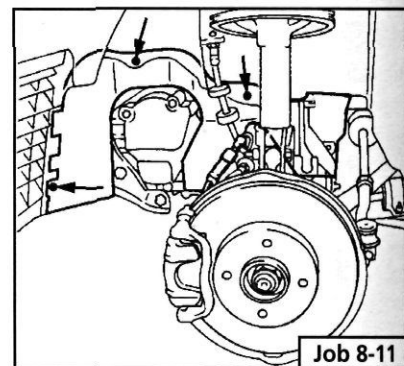

G Step 12:

Disconnect both trackrod ends from their steering arms.

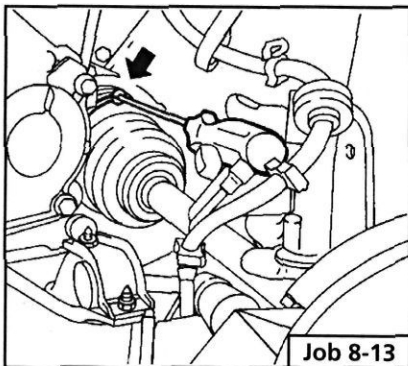

Job 8-13

LJ Step 13:

Remove the fixing bands (arrowed) on the protective boots on the inner ends of the drive-shafts.

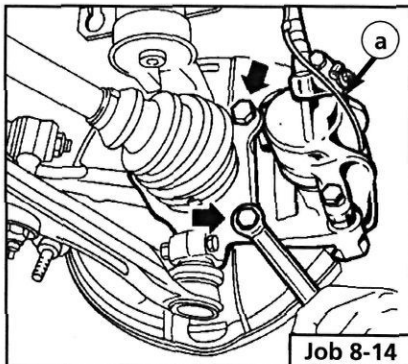

Job 8-14

Step 14:

Unplug the brake pad wear sensors (a) if fitted. Unbolt (see arrows) the complete caliper support bracket. Hang each caliper and bracket in their wheelarches, taking care not to strain or damage the hydraulic hoses.

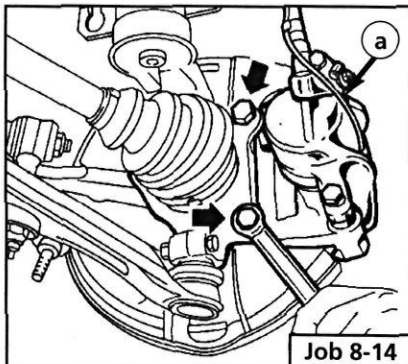

Job 8-14

Step 15:

Undo and remove the suspension strut to stub axle nuts and bolts (arrowed - two each side). Pull the tops of the stub axles clear of the struts.

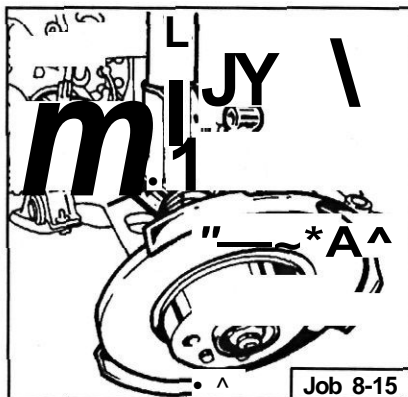

Job 8-15

Step 16:

Unbolt the lower suspension arms (arrowed)...

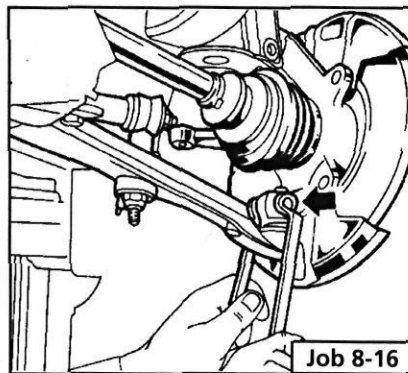

Job 8-16

Step 17:

...remove the drive shaft assemblies from their housings in the gearbox...

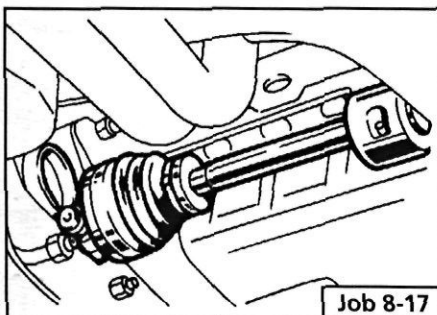

Job 8-17

Step 18: ...and remove each complete front hub, drive-shaft and brake disc assembly.

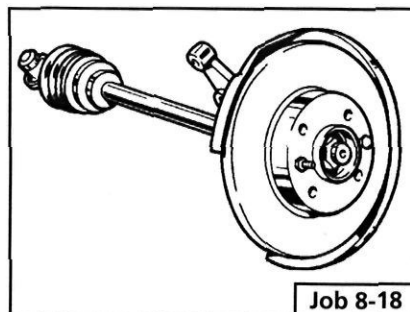

Job 8-18

LI Step 19:

Disconnect the gear selector linkage and place it out of the way, in the lower part of the engine compartment.

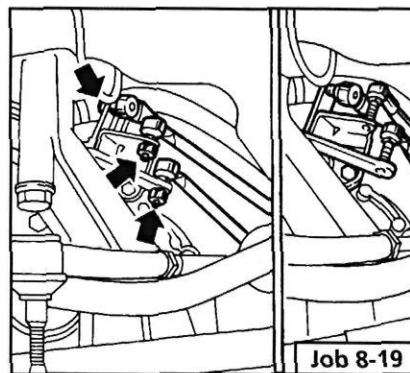

Job 8-19

L) Step 20:

Support the power unit, just keeping its weight off the mountings.

Q INSIDE INFORMATION! This can be done from underneath with a trolley jack and piece of wood on its pad to prevent damage - or by means of a hook from above. **Q**

Step 21:
Remove the nuts (1) holding the centre support to the gearbox, and those (2) holding the flywheel shield.

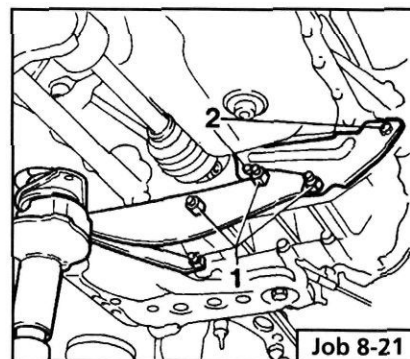

Job 8-21

Step 22:

Remove the centre support/mounting (a) and the flywheel shield (b).

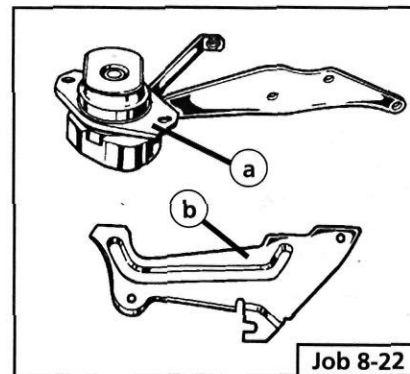

Job 8-22

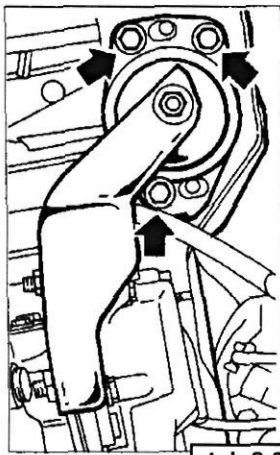
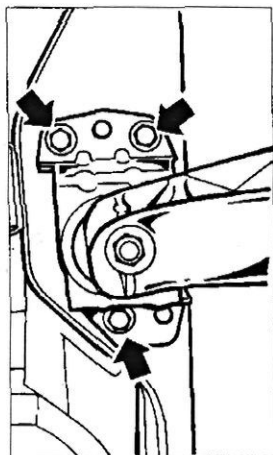
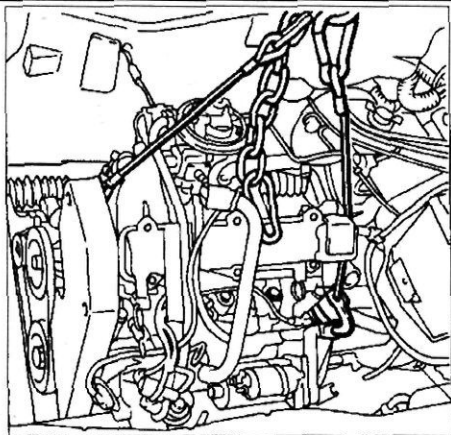

Job 8-23

Q Step 23: Undo the mounting bolts, making sure the power unit is supported safely as you take the last bolts out.

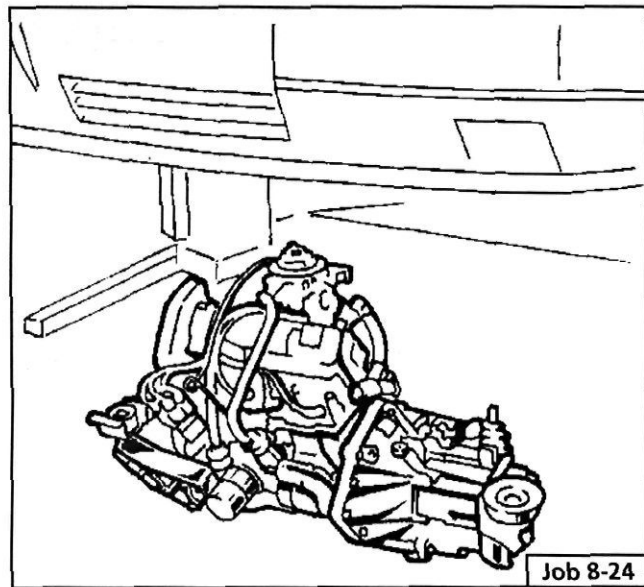

Job 8-24

Q Step 24: Lower the power unit to the ground and pull clear.

Job 9. Petrol engine/transmission - refitting.

Q INSIDE INFORMATION! The power unit can be refitted by simply reversing the order of the operations for removal as set out in the previous job. However, the following points should receive your attention as the work progresses. **Q**

Q Step 1: Refer to *Chapter 3, Facts and Figures* for the torque settings when refitting the various components.

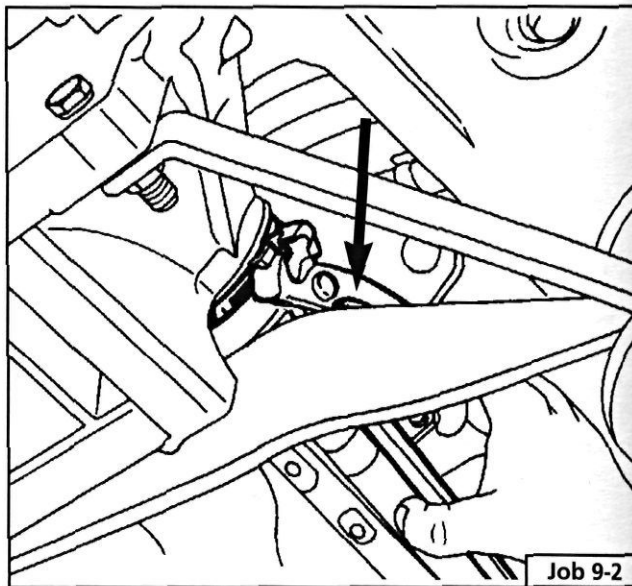

Job 9-2

Q Step 2: If you don't have the FIAT tool (arrowed) to fit the special Oetiker bands on the drive-shaft boots, use woodworker's pincers, or fit new jubilee clips and screw them reasonably tight.

Q Step 3: Check the condition of all hoses and clips and replace them if suspect.

Q Step 4: Make sure all the electrical connections are correctly made and are sound.

L) Step 5: Make sure the engine and gearbox have the correct grades and quantities of oil. See *Chapter 3, Facts and Figures*.

QI Step 6: Check that the cooling system has the correct coolant mixture. See *Chapter 3, Facts and Figures*.

d Step 7: Make a final check that nothing has been left unconnected before starting up.

Q Step 8: Run the engine up to working temperature and then switch off. Check for leaks and re-check the fluid levels when cold.

**Job 10. Petrol engine/
transmission (removed from car)
- separation.**

making it easy!

- Clean the whole unit with a proprietary degreaser - and dry off before starting work.

• This makes these heavy components easier and safer to handle and greatly reduces the risk of contamination when you strip them down.

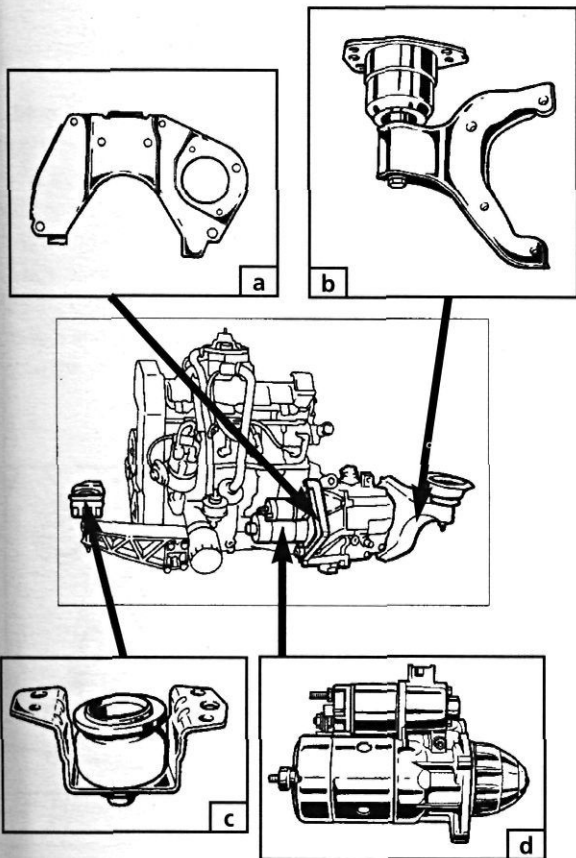

Job 10-1

Step 1: Undo and remove the transmission mounting bracket (b), the starter motor (d) and unbolt and remove the pressed steel cover plate (a) from the lower face of the flywheel housing. Undo the flywheel housing connecting bolts and note the position of the engine and transmission mounting brackets and lifting eyes. The engine mounting arm can be left in place but the mounting itself (c) can now be removed, if required.

Step 2: Support the weight of the transmission so that it doesn't 'hang' on the clutch and withdraw it from the engine in a straight line.

**Job 11. Petrol engine/
transmission (removed from car)
- reconnection.**

Refer to **Job 10** for the location of components referred to here.

U Step 1: Offer the transmission to the engine. The input shaft should slide easily through the splined hub of the driven plate, provided that it is still centralised. See **PART B: TRANSMISSION** Re-centre the clutch if necessary.

making it easy!

- If the input shaft and hub splines are not aligned, ask a helper to turn the crankshaft pulley nut while you apply gentle pressure to bring the two units together.

LJ Step 2: Once the input shaft is properly engaged, use two bolts, tightened evenly, to draw the units together. **DON'T** force it! If the units don't come together easily, separate them, check clutch centring and try again. Fit the remaining bolts, not forgetting the lifting eyes and brackets.

LJ Step 3: Refit the flywheel housing cover plate and mounting bracket.

I Step 4: Refit the starter motor.

**Job 12. Petrol engine.
Mountings - replacement.**

See **Job 8, Steps 21 to 23** for details of engine and transmission mounting positions.

making it easy!

- Change one mounting at a time.
- The others will help you keep the power unit correctly positioned.

LJ Step 1: Support the weight of the power unit with a jack until there is no upward or downward pressure on the mounting to be changed.

LJ Step 2: Undo the securing bolts and fit the new mounting. Remove the supporting jack.

B INSIDE INFORMATION! If you unbolt the whole of the rear mounting bracket, be sure to replace the two bolts which go into the gearbox casing to prevent oil leakage. Q



FACT FILE: DIESEL ENGINES AND SPECIAL TOOLS

•As the construction and assembly of the diesel engine is, for the best part, the same as the petrol engines, this section details only those procedures which are specific to the diesel.

• Major differences lie in the areas of the cylinder head and camshaft drive belt.

•Where inspection of components such as crankshaft, camshaft, pistons, conrods, cylinder head face, flywheel etc. is not detailed within this section, refer to the relevant information in the *Petrol Engine* section, *Job 6*, under *Checking for wear* - information which is common to all engine types.

• In view of the complexity of the diesel engine's camshaft drive arrangement, the need for special tooling and the accuracy required in adjusting camshaft timing and injection pump timing, we strongly recommend that any work involving disturbance of the timing belt or injection pump is entrusted to a FIAT dealer.

• The following information is provided only for those who have technical experience of diesel engines, along with access to the required tooling.

• Familiarise yourself with this drawing, showing the cylinder head, block and other major components referred to in the following text.

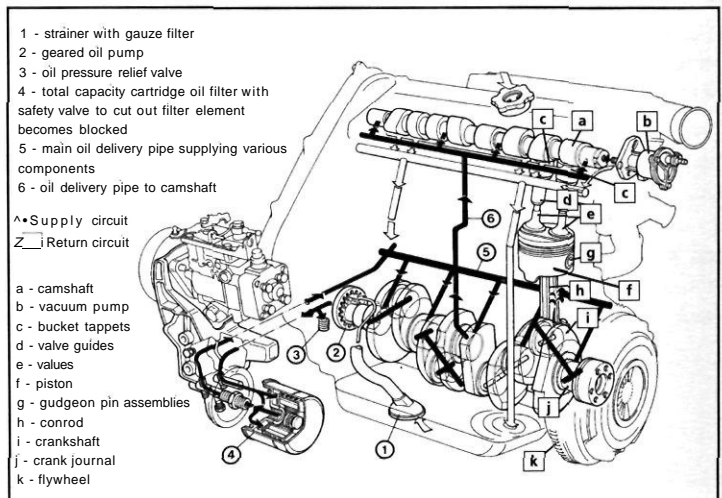
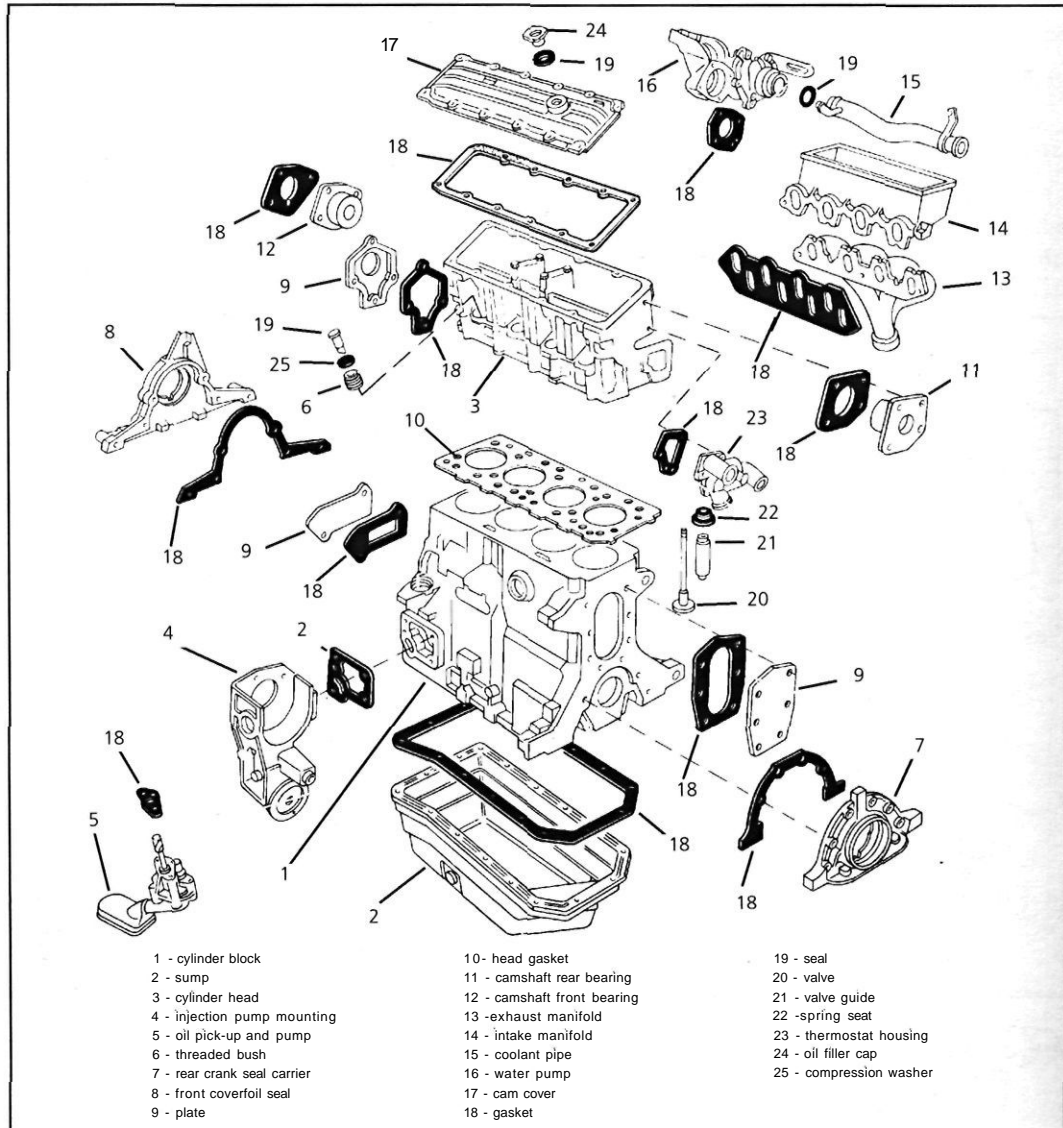

Job 13. Diesel engine. Timing belt - replacement and adjustment.

- **Step 1:** Undo the bolts and remove the top timing belt cover.

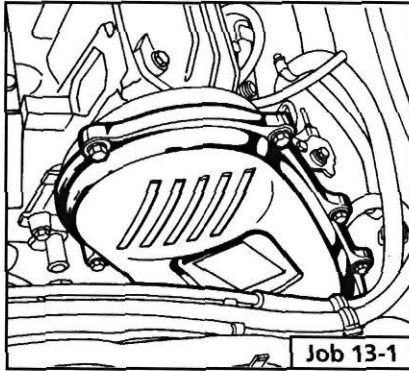

- **Step 2:** Securely support the car and remove the right hand front wheel for access to the wheel arch dust shield. Undo the fasteners (arrowed) and remove the shield.

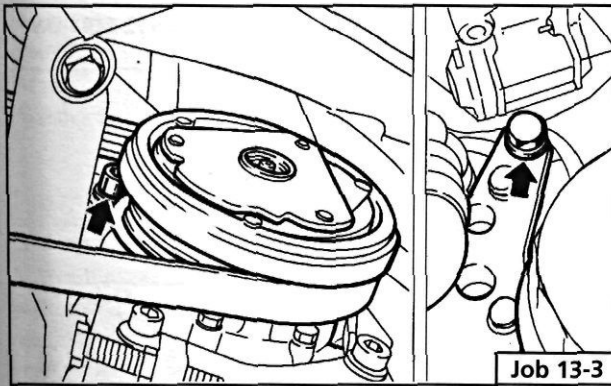
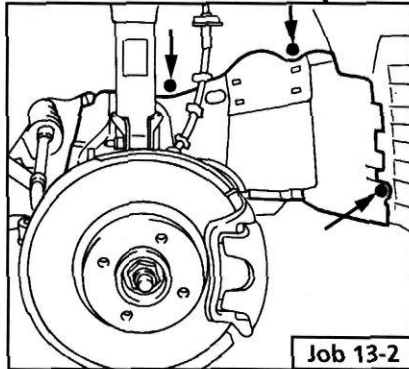

- **Step 3:** Slacken the power steering pump support bracket securing bolts (arrowed).

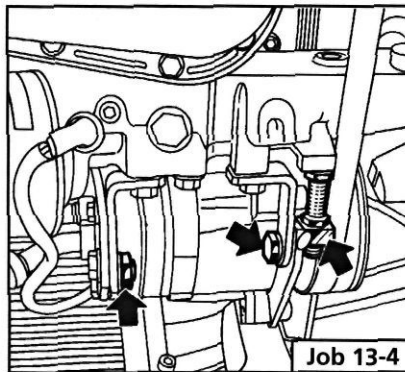

- **Step 4:** Slacken the bolts holding the power steering pump to the bracket (arrowed).....

- **Step 5:**and remove the drive belt, allowing it to hang on the engine support bracket (arrowed).

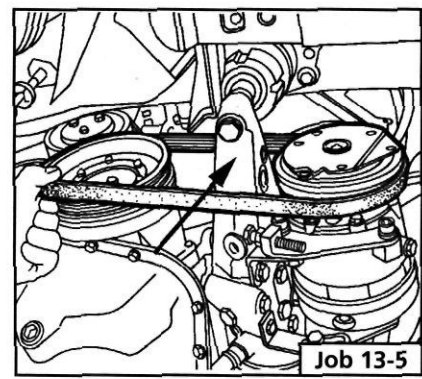

- **Step 6:** Slacken the alternator mounting bolts, and remove the drive belt.

- **Step 7:** Ensure that the notch on the crankshaft pulley/damper (arrowed) is aligned with the ridge on the lower half of the timing belt cover (arrowed),.....

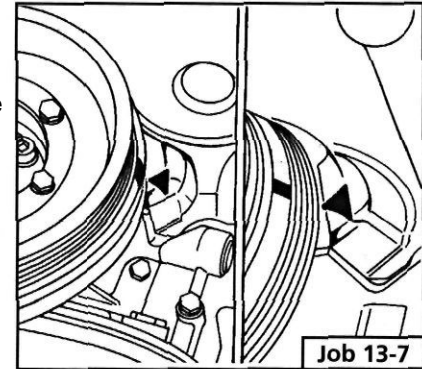

- **Step 8:**then undo the securing bolts (arrowed) and remove the cover (inset).

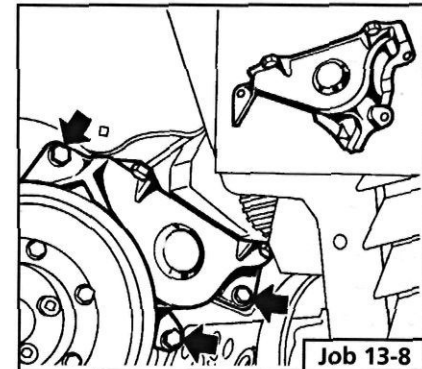

- **Step 9:** Undo the bolts (arrowed) and remove the flywheel cover guard (inset).

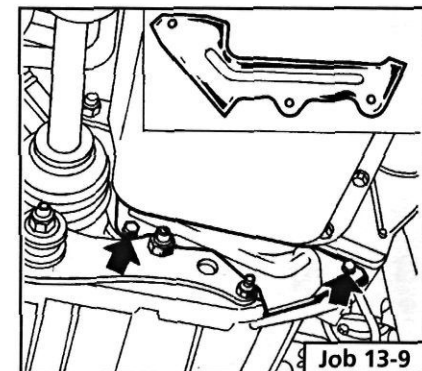

IMPORTANT NOTE: From now on, one of two different procedures will be required, depending upon the age of your diesel engine, as modifications were made from engine No. 1723291 -on to allow fine adjustment of camshaft timing. Both procedures require the use of FIAT special tooling, which it may be possible to hire from your local specialist - otherwise you will have to make your own tools or have the work carried out for you.

PART A - ENGINES PRIOR TO ENGINE NO. 1723291

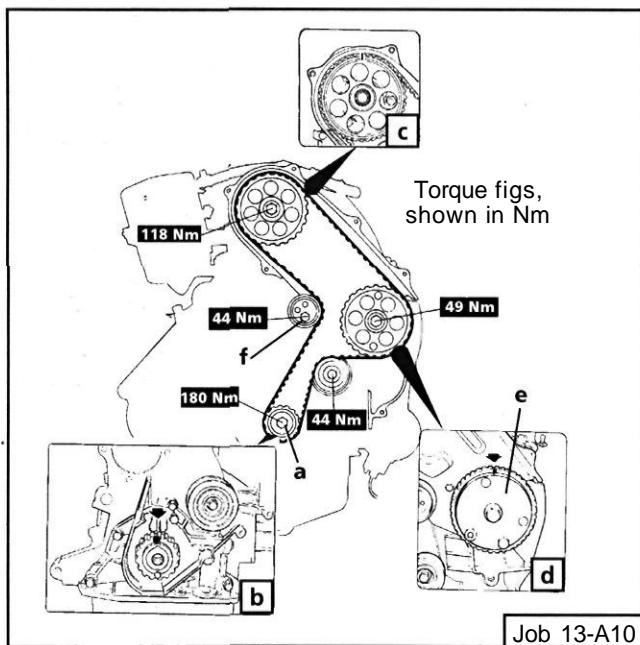

LJ Step A10: Use a spanner on the crankshaft bolt (a) to turn the engine until the timing marks on the crankshaft, camshaft and injection pump sprockets align with their respective reference marks. Align the crankshaft sprocket with the notch on the front cover (b). Align the camshaft sprocket with the hole in the timing belt cover (c). Align the injection pump sprocket with the reference on the timing belt rear guard (d).

LJ Step A11: Use the FIAT flywheel lock, part no. 1860766000 (or construct your own tool) to stop the crankshaft from turning.

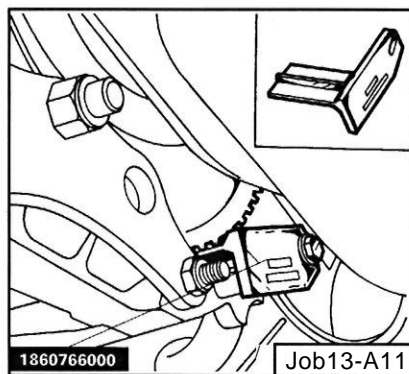

• **Step A12:** Remove the alternator belt pulley/damper.

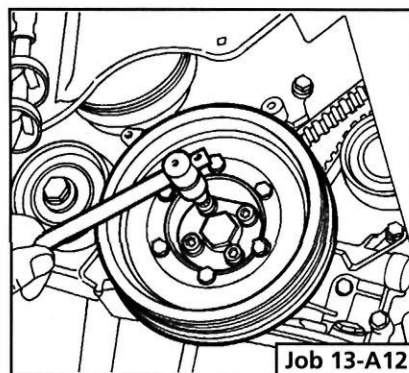

• **Step A13:** Using FIAT tool no. 1842128000 (see illustration *Job 13-A10, parte*), lock the injection pump sprocket to prevent it turning.

Q Step A14: Slacken the belt tensioner nut (see illustration *Job 13-A10, part f*), move the tensioner away from the belt and temporarily lock it in position.

U Step A15: Ease the timing belt off the sprockets.

H Step A16: Fit the new belt, first making sure that all of the timing marks still align.

Q Step A17: If you do not have access to the correct FIAT tensioning tool, release the locknut, push the tensioner firmly into the belt and lock it up by tightening its bolt.

If you do have the FIAT special tool (a weighted bar), attach it to the tensioner, which will move to the position of correct tension. Lock the tensioner bolt. Remove the special tool locking the injection pump sprocket.

Q INSIDE INFORMATION: If you can't put enough pressure on the tensioner with your fingers, carefully use a long screwdriver as a lever. Alternatively, push a pair of bolts into the two holes in the tensioner and lever between them to turn the tensioner. **Q**

H Step A18: Rotate the engine through two revolutions. If the belt is correctly tensioned you should just be able to twist it through a quarter-turn when gripping it between thumb and finger in the centre of its longest run between sprockets. Adjust as necessary.

H Step A19: Refit the remaining parts in the reverse order, then check the injection timing (see *Chapter 5, Servicing Your Car, Job 39*).

PART B - ENGINES FROM ENGINE NO. 1723291-ON

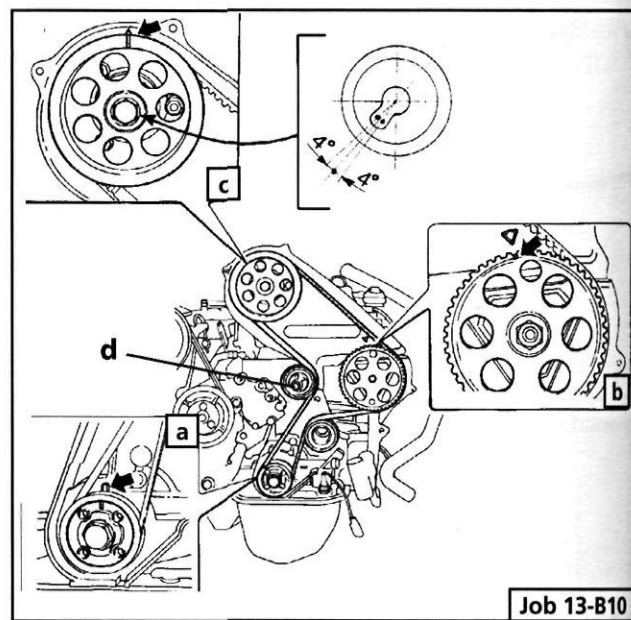

Q Step B10: Turn the crankshaft in its normal direction of rotation until the marks on the crankshaft sprocket (a) and fuel injection pump sprocket (b) line up with the fixed marks on the engine. This will place cylinder No. 1 at Top Dead Centre TDC and set the camshaft for the power stroke of the same cylinder. Lock the flywheel (see *Step A11*) and remove the alternator belt pulley (see *Step A12*).

IMPORTANT NOTE: The hole for fixing the camshaft sprocket (c) has a fine-adjustment slot, so it is possible that the mark on the sprocket may not line up exactly with the mark on the cover.

L) **Step B11:** Undo the belt tensioner nut (see illustration *Job 13-B10, part d*), then remove the timing belt.

L) **Step B12:** Undo the nuts securing the brake vacuum pump to the cylinder head (see illustration *Job 16-1*), and remove it.

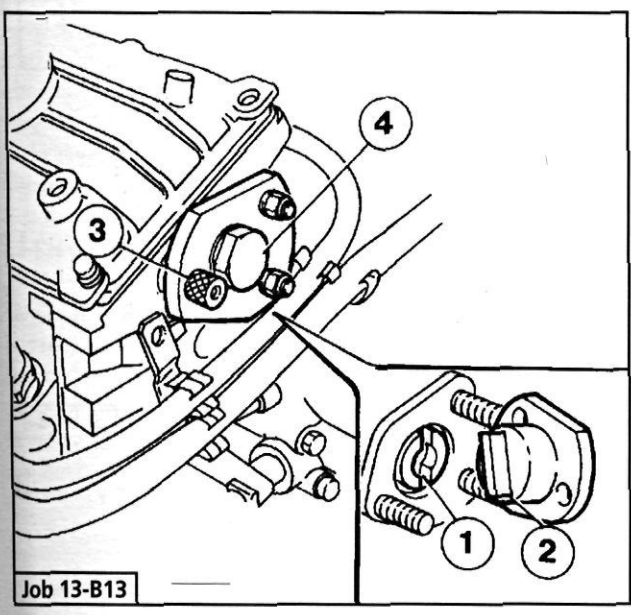

Q Step B13: Fit FIAT tool no. 1860932000 (for setting camshaft timing) to the vacuum pump end of the camshaft, matching the camshaft groove (1) with the lug (2) on the tool. Secure the tool to the cylinder head, positioning the centring dowel (3) as shown. The dowel must be perfectly centred on the tool, and if it isn't, you should adjust the hexagonal bolt (4) with a spanner, and centre it with tiny movements.

Step B14: Remove the bolt (arrowed) which secures the front cover to the engine block, then fit the timing belt on the crankshaft sprocket.

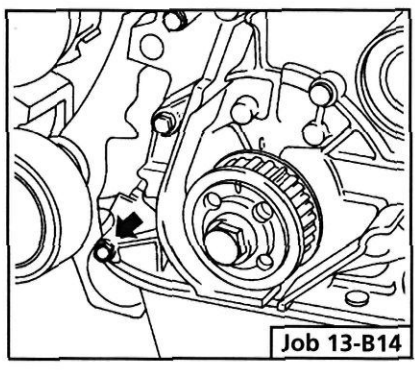

U Step B15: Fit FIAT tool No. 1860933000 for precise determination of TDC on cylinder No. 1. The tool must be secured firmly by two bolts to the crankshaft sprocket, and by another bolt to the crankshaft front cover (where the bolt was previously removed in **Step B14**).

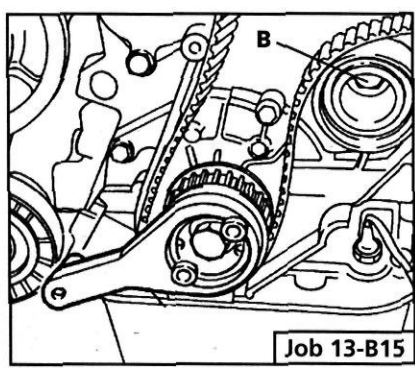

Step B16: Lock the injection pump sprocket (see **Step A13**). Now, using FIAT tool no. 1860831000, slacken the bolt securing the camshaft sprocket.

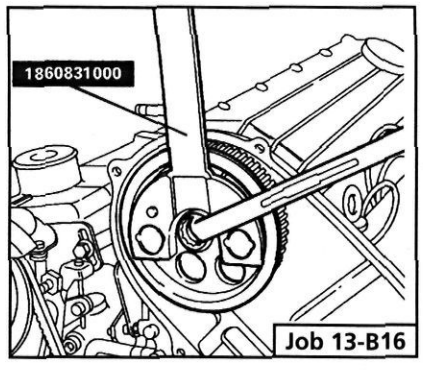

Q Step B17: Continue fitting the timing belt in the following sequence: crankshaft sprocket, fixed tensioner, injection pump sprocket, timing sprocket, belt tensioner... and check that the mark on the injection pump lines up with the fixed mark on the rear cover.

Q Step B18: Use the timing belt tensioner to correctly tension the belt.

H INSIDE INFORMATION: If you do not have the correct tensioning tool, follow **Steps A16** and **A17**.

Q Step B19: Tighten the camshaft sprocket bolt to the specified torque (see **Chapter 3, Facts and Figures**).

LJ Step B20: Turn the crankshaft by two revolutions (clockwise), tighten the belt tensioner to the specified torque (see **Chapter 3, Facts and Figures**) and remove the tensioning tools. If the belt is correctly tensioned you should just be able to twist it through a quarter-turn when gripping it between thumb and finger in the centre of its longest run between sprockets. Adjust as necessary.

Q Step B21: Refit the remaining components in the reverse order of removal, then check the injection timing. See **Chapter 5, Servicing Your Car, Job 25**.

Job 14. Diesel engine. Cylinder head - removal.

SAFETY FIRST!

- Disconnecting the high pressure pipes on a diesel injection system can be dangerous!
- Head the **Safety First!** information at the start of **PART F: FUEL AND EXHAUST SYSTEMS** before starting work.

Q Step 1: Refer to **Job 13** and remove the timing belt.

Q Step 2: Drain the cooling system and disconnect the air pipes from the inlet manifold.

Q Step 3: Disconnect and remove the oil vapour pipes from the cylinder block device.

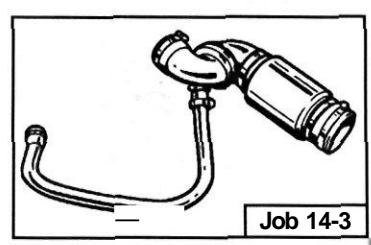

- **Step 4:** Disconnect the brake servo pipe from the vacuum pump (a) and all the water hoses from the thermostat (b).

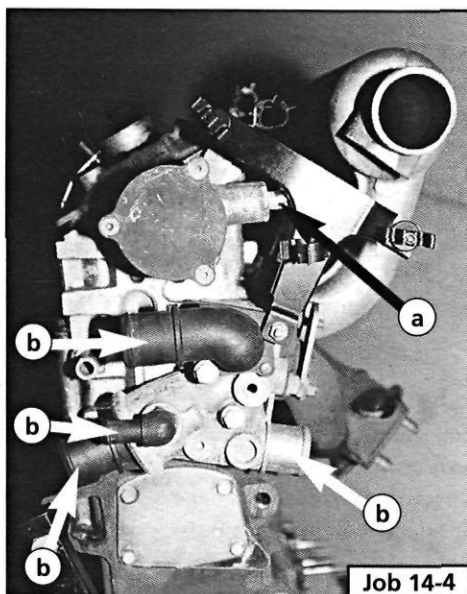

- **Step 5:** Disconnect the heater supply hose from the cylinder head.

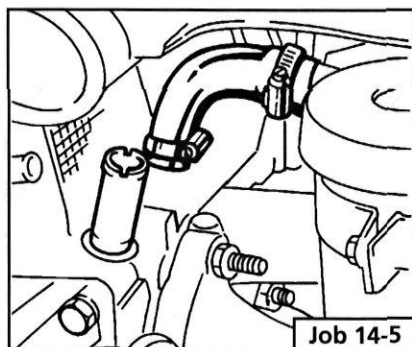

- **Step 6:** Unplug the temperature warning light connector from the cylinder head.

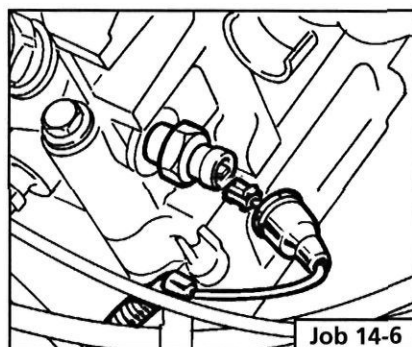

- **Step 7:** Disconnect the glow plugs, supply lead (arrowed).

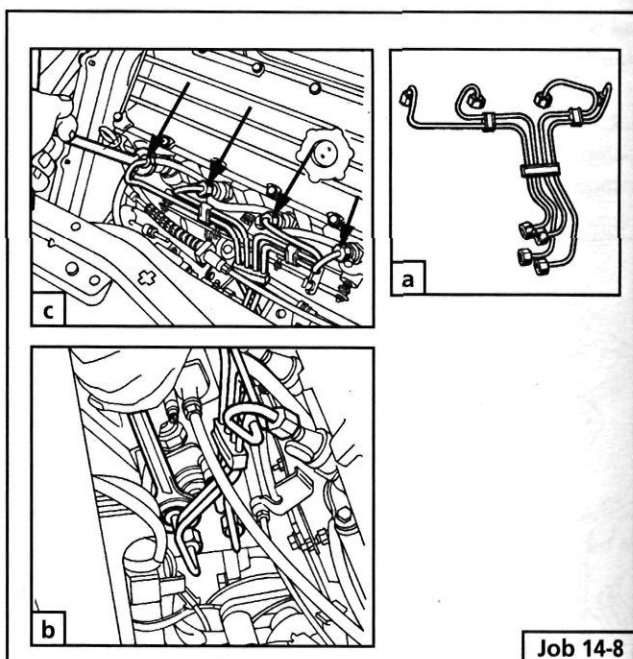
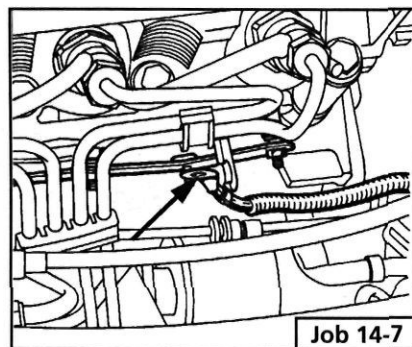

- U Step 8:** Disconnect and remove the fuel delivery pipes (a) - from the pump (b) and from the injectors (c).

- Q Step 9:** From the cylinder head, disconnect the coolant hoses leading to the expansion tank and the coolant pump.

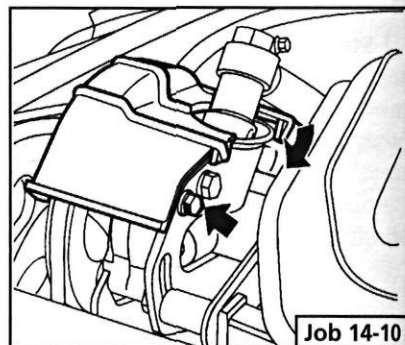

- **Step 10:** Undo the bolts (arrowed) and remove the power steering pump cover.

- Q Step 11:** Undo the bolts securing the pump to the inlet manifold (arrowed) and tie the pump clear.

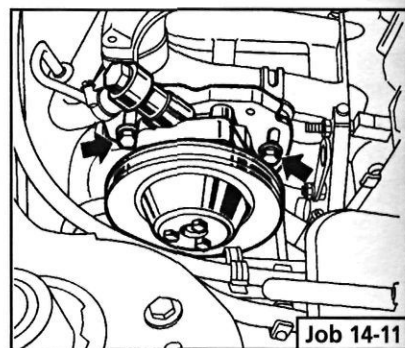

- **Step 12:** Undo the bolts (arrowed) and remove the power steering pump support bracket.

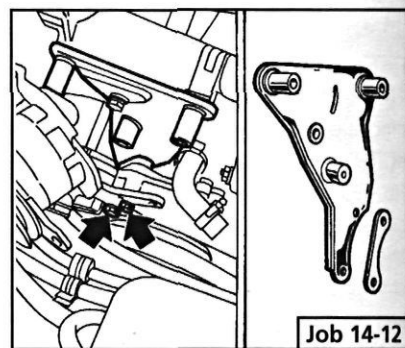

Step 13:
Remove the bolt securing the dipstick tube (arrowed) and the bolts fixing the rear timing belt cover to the injection pump support bracket (arrowed). Also, remove the dipstick tube, if fitted to the support bracket.

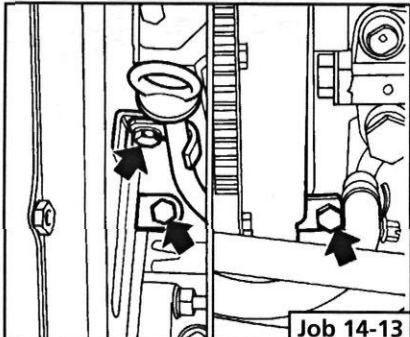

Job 14-13

Step 14: Undo the three exhaust flange nuts (arrowed) and remove the springs from behind them. Separate the pipe from the manifold.

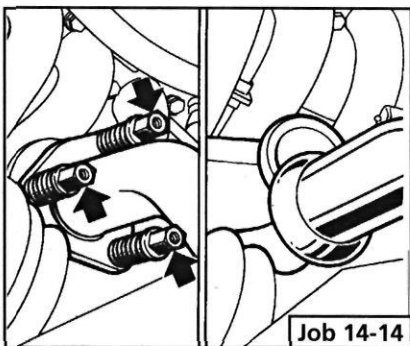

Job 14-14

Step 15:
Unbolt the inlet and exhaust manifold bolts...

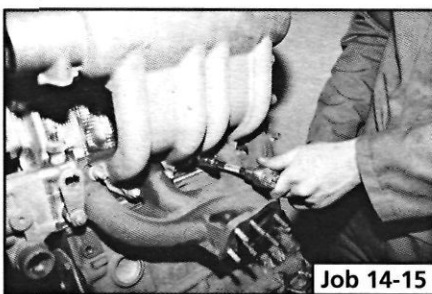

Job 14-15

Step 16:
...and remove the manifolds.



Job 14-16

Step 17:
Unscrew the twelve bolts and remove the cam cover.



Job 14-17

Step 18:
Unbolt the cylinder head (removing the oil pipes, if fitted)...

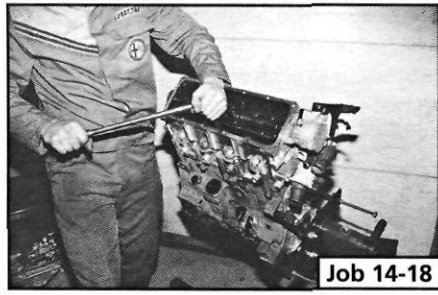

Job 14-18

Step 19:
...undoing the head bolts half a turn at a time, in the order shown, until all are loose.

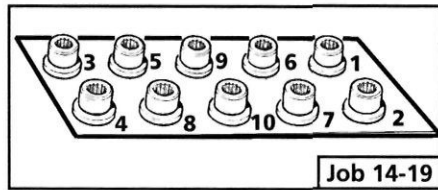

Job 14-19

Step 20: Not forgetting the row of five smaller, outer bolts.

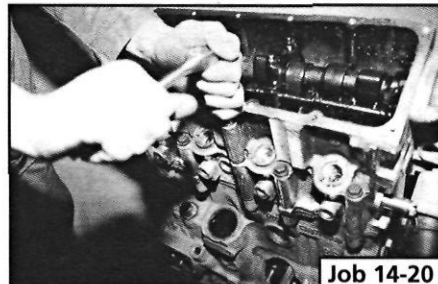

Job 14-20

Step 21: Have a good look to check that there is nothing still connected and preventing removal of the cylinder head. With the help of an assistant, lift the cylinder head from the engine block. If you prefer, you can lift the head complete with manifolding, (turbo charger if fitted) and the inner top part of the timing cover and remove them later.

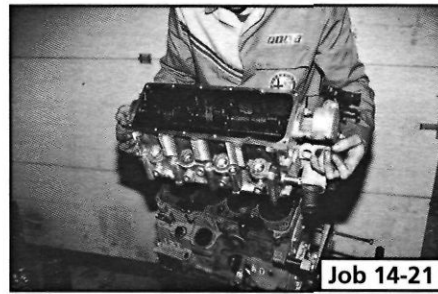

Job 14-21

SAFETY FIRST!

• The cylinder head is heavy and should be lifted from the engine bay by two people.

Job 15. Diesel engine. Cylinder head - refitting.

Step 1: Put the pistons at TDC - two at a time - and measure how much they protrude above the block surface. This is ideally done using a dial gauge and holder (FIAT tools 1895882000 and 1870404000, respectively) but if surfaces

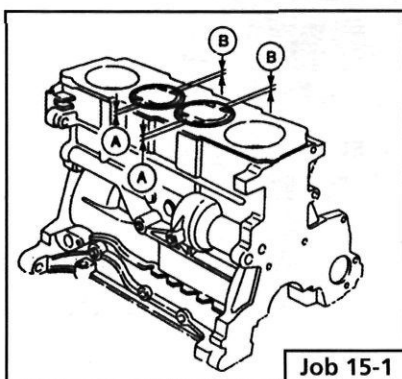

Job 15-1

- Repeat this operation three more times until the complete code number has been entered, if the code has been entered in correctly LED B will start flashing.
- Release button A (see illustration 1B). Red LED B flashes for 8 seconds indicating the new remote unit's code has been stored.

IMPORTANT NOTE: If the LED does not illuminate when remote unit button (illustration 1B, button O is pressed, change the remote unit's battery.

SWITCHING OFF THE ALARM

1C. Some models are fitted with an alarm exclusion switch, which can be found inside the glove compartment. If the alarm is faulty or the remote control batteries are flat:

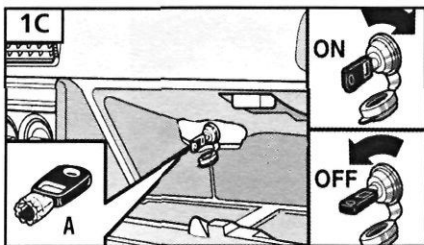

- Insert the emergency key A into the emergency switch slot in the glove compartment turn the key to the left to switch the alarm off (see inset).
- Turn the key back towards its original position to switch the alarm system back on.

IMPORTANT NOTE: As the alarm system absorbs energy, if you are not planning on using the car for a long period of time, turn the alarm exclusion key to the off position, so as not to run the vehicle battery down.

• 2. IGNITION SWITCH AND STEERING COLUMN LOCK

IGNITION SWITCH

2. The ignition/steering column lock key, once inserted in the ignition lock, can be placed in any of the following four positions:

- **PARK**-With the key in this position the side and tail lights can be turned on, the steering column locked and the keys can be removed. Press button A to turn the key to PARK.



- **STOP** - When the key is turned to the STOP position the steering column will be locked, and the keys can be removed.

- **MAR** - This is the driving position. When the key is in this position all the electrical devices are energised.

- **AVV** - Turning the key to this position starts the engine.

STEERING COLUMN LOCK

- **LOCKING** - To apply the steering wheel lock turn the steering wheel slightly to the left or right when the key is at STOP or PARK.

- **LOCKING** - Rocking the steering wheel gently back and forth while turning the ignition key to MAR unlocks the steering wheel.

SAFETY FIRST!

- *Never remove the key when the car is moving. If you do, the steering wheel will lock the first time you turn it*
- *If the ignition lock has been tampered with or shows any sign of damage (e.g. attempted theft), have the lock checked at your nearest FIAT ServiceCentre.*

DASHBOARD

• 3. PANEL INDICATORS

INSTRUMENT DISPLAY PANEL

3. These are the instrument panel warning LED indicators for all FIAT Tipo/Tempra models. Your vehicle will only have Panel! Indicators relevant to your particular car.

| | | | |
|--|--------------------------|--|---------------------------------------|
| | Choke | | Oil pressure warning |
| | Direction indicators | | Handbrake engaged |
| | Side lights | | Rear window defroster |
| | High beam head lights | | Injection system warning light |
| | Rear fog lights | | Battery warning |
| | Hazard warning lights | | Seat belts not buckled |
| | ABS brake warning | | Automatic transmission fluid warning |
| | Brake pad wear warning | | Doors not properly closed |
| | Turbo pressure warning | | Trailer direction indicators |
| | Front fog lights | | Diesel fuel filter condensate warning |
| | Diesel heater/glow plugs | | |

3

J 4. ELECTRONIC CHECK PANEL

4. The electronic check panel is not fitted to models with basic trim.

IMPORTANT NOTE: The check panel will not indicate if the tail light fuses blow at the same time, or if there is a circuit failure within the panel display.

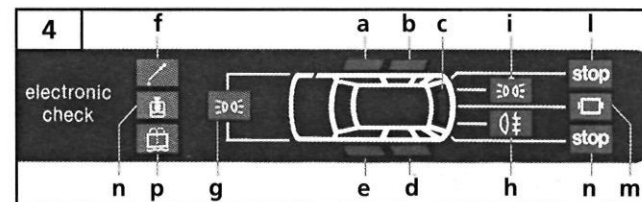

SIDE AND HATCHBACK DOORS

When the ignition key is at MAR, the check panel LEDs g, h, i, l, m and n monitor the light bulbs and fuses. LEDs a, b, c, d, and e monitor incomplete closure of the side doors and hatchback.

are very clean, and great care is taken, it is possible to take an average protrusion measurement based on measuring the protrusion at each side (A) and (B) of the piston crown, using a steel straight-edge and feeler gauges. Use the HIGHEST average measurement of the four pistons as your working figure.

- **Step 2:** Now, referring to the illustration, select the appropriate one of the three available cylinder head gasket thicknesses as follows:

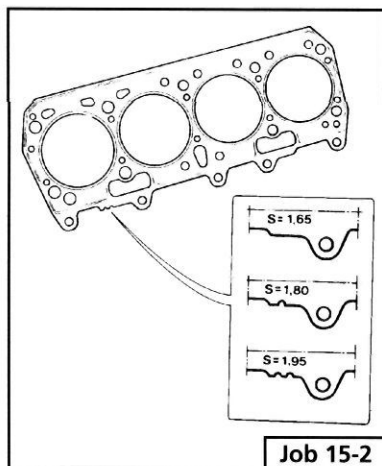

Job 15-2

| Measured protrusion | Gasket identification |
|---------------------|------------------------------|
| Up to 1.05 mm | No notches (1.65 mm gasket) |
| 1.05- 1.20 mm | One notch (1.80 mm gasket) |
| Over 1.20 mm | Two notches (1.95 mm gasket) |

H INSIDE INFORMATION! The cylinder head gasket is of the special 'ASTADUR' type and polymerises during engine use, becoming much harder. It should only be removed from its wrapping immediately before fitting and then should be kept free of contamination by oil, grease or water. Fit only between clean and dry cylinder head and block surfaces. **B**

- ⌋ **Step 3:** Discard the old gasket and thoroughly clean the cylinder block mating surface and dry off. Make sure that the bores are free of gasket particles.

Q INSIDE INFORMATION! It is important to be sure that all the cylinder head bolt holes in the block are clear right down to their bottoms. The bolts and washers should be cleaned, lubricated with engine oil and then drained for at least 20 minutes before fitting. **Q**

- ⌋ **Step 4:** Clean the cylinder head, taking care not to gouge the aluminium surface - use a straight edge that isn't too sharp.

- ⌋ **Step 5:** Place the new gasket on the cylinder block with the word 'ALTO' facing upwards.

- ⌋ **Step 6:** Lower the head into position and screw all the bolts in finger tight.

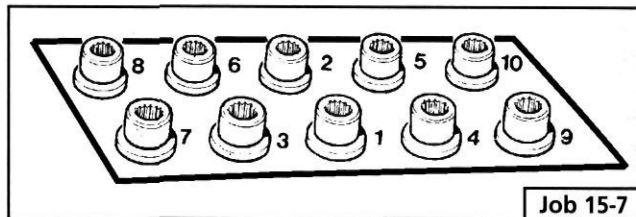

Job 15-7

- ⌋ **Step 7:** Note the numbered tightening order of the ten main cylinder head bolts. Using a suitable torque wrench, proceed to tighten the ten main bolts in the following sequence:

Stage i) Tighten to 50 Nm.
 Stage ii) Tighten to 100 Nm.

- **Step 8:** Using a suitable bar, continue to tighten IN EXACTLY THE SAME ORDER AS BEFORE, as follows:

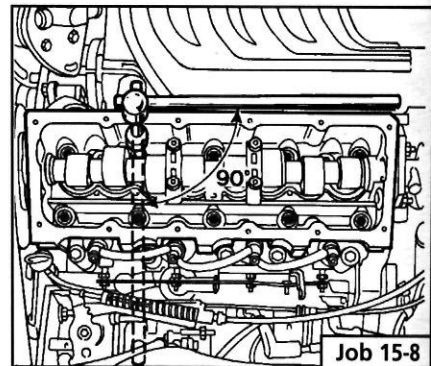

Job 15-8

Stage iii) Tighten each bolt through ninety degrees (one quarter turn).
 Stage iv) Tighten each bolt through a further ninety degrees.

- **Step 9:** Finally, using a torque wrench. Tighten the five remaining smaller bolts to 30 Nm.

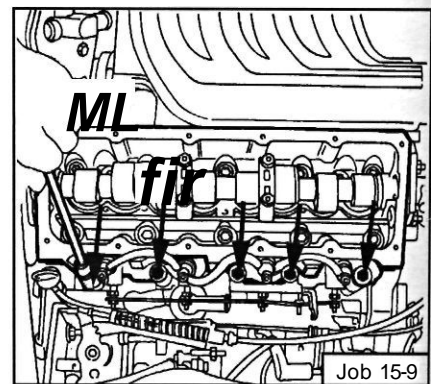

Job 15-9

CJ Step 10: Now reverse the remaining steps in **Job 14o** reinstate all items removed or disconnected during removal of the cylinder head. See *Chapter 3, Facts and Figures* for relevant torque figures and the coolant mixture and capacity.

- **Step 11:** Bleed the fuel system - refer to **PART F: FUEL AND EXHAUST**.

L) Step 12: Prior to initial start up, check that everything is properly connected and secured. Run the engine to normal working temperature, switch off and check all fuel lines and coolant hoses for leaks. Allow to cool and check the coolant level.

**Job 16. Diesel engine.
Cylinder head - overhaul.**

• **Step 1:** Undo the three nuts farrowed), take off any associated brackets and fittings...

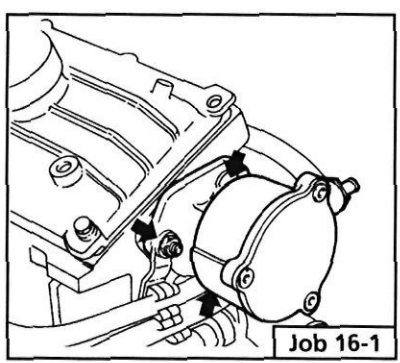

• **Step 2:** ...and remove the brake vacuum pump from the rear of the cylinder head.

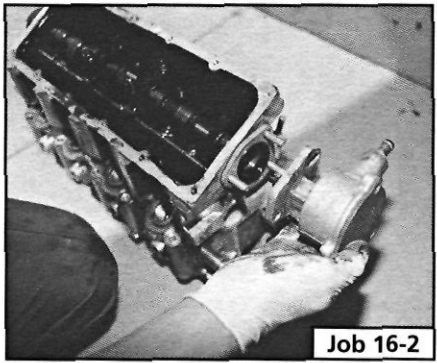

• **Step 3:** Unbolt and remove the inlet manifold and exhaust manifolds (with turbo if fitted). See Job 14.

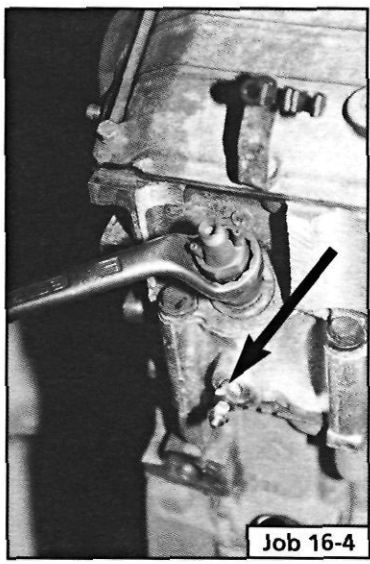

U **Step 4:** Unscrew and remove the glow plugs (arrowed), the injectors and the injector compression washers, taking care not to damage them. See PART F: FUEL AND EXHAUST.

□ **Step 5:** Undo the retaining nuts holding the camshaft end-bearing to the rear-end of the engine and tap out both of the camshaft end-bearings with a suitable drift...

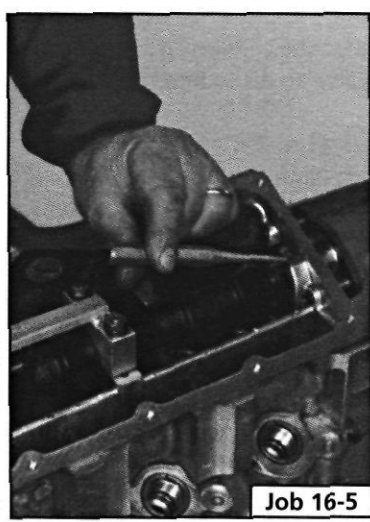

• **Step 6:** ...drifting against the face shown here.

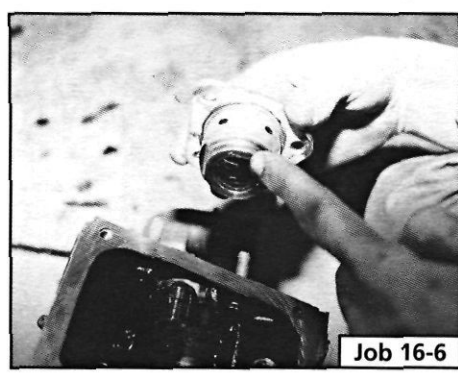

• **Step 7:** This is the rear bearing which is removed in the same way.

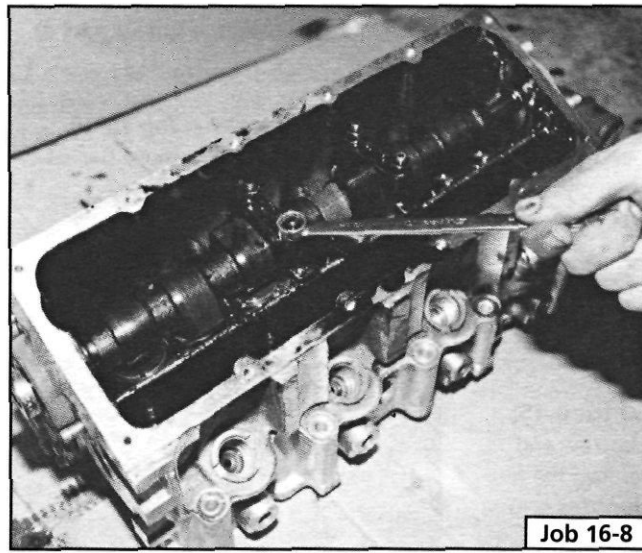
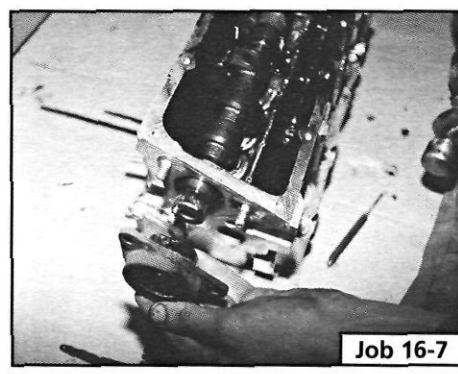

d **Step 8:** Undo the centre bearing cap nuts evenly and progressively until there is no pressure. Remove both bearing caps, noting their positions so that you can refit them in the same order.

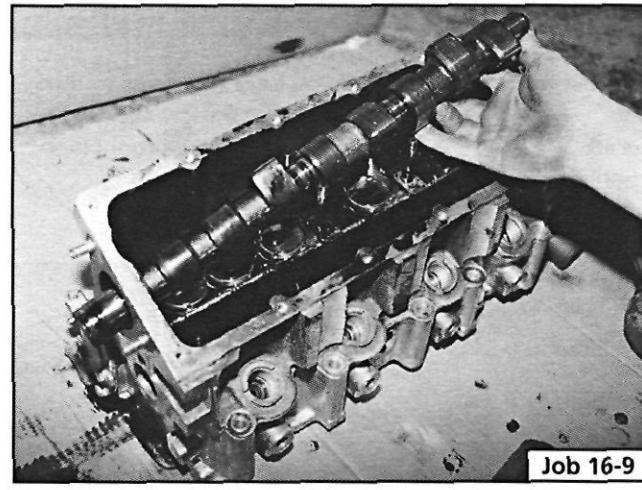

□ **Step 9:** Remove the camshaft by moving it sideways, by enough to clear one end, then lift it out through the top.

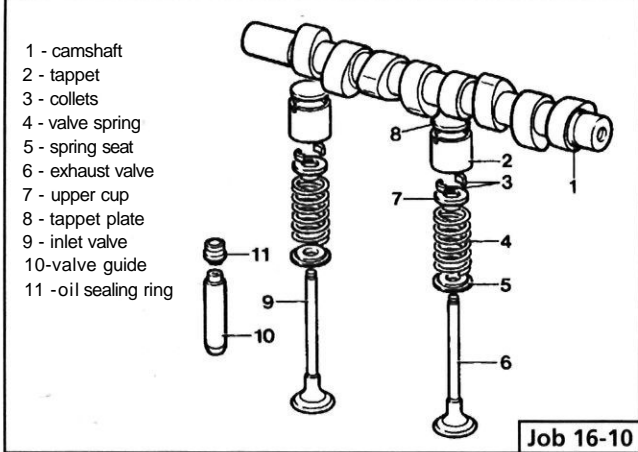

LJ Step 10: Remove the cam followers (2) complete with shims (8) and keep them in order so that they can be refitted in the same positions.

LJ Step 11: Using a suitable valve spring compressor, compress the spring of the first valve and remove the split collets (illustration *Job 16-10, part 3*).

LJ Step 12: Carefully release the spring compressor- Remove the valve spring cap (*Job 16-10, part 7*), the spring (*part 4*) and spring seat (*part 5*).

LJ Step 13: Withdraw the valve (illustration *Job 16-10, parts 6 and 9*) from its guide (*part 10*) and remove the valve stem oil seal (*part 11*).

LJ Step 14: Remove the remaining valves and keep each set of components together and in the correct order, discarding the old stem seals.

• **Step 15:**
 Unscrew and remove the four threaded bushes which secure the pre-combustion chambers. FIAT use their tool No. 1850178000 for this purpose.

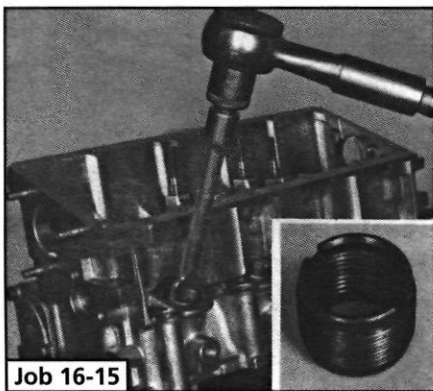

Q INSIDE INFORMATION! If you have no access to this tool, you will need to make a simple flat-bladed tool to locate in the slots provided in the bush. The tool blade should be 31.5 mm wide by 5 mm thick. **Q**

• **Step 16:**
 Remove the pre-combustion chambers by tapping them out with a small drift.

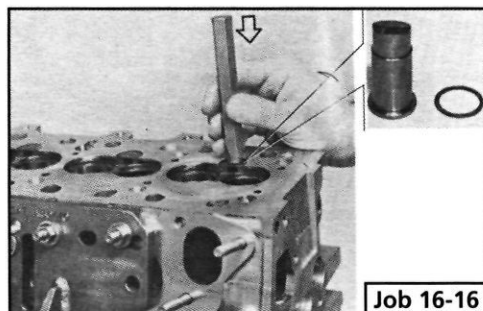

LJ Step 17: Thoroughly clean the cylinder head and components with paraffin or an engine cleaning solvent. Take great care not to gouge the face of the cylinder head. The valves are best cleaned with a rotary wire brush.

Q Step 18: Check the cylinder head for distortion by using a straight edge along the machined surface, and a feeler gauge. Any distortion above 0.1 mm indicates the need for machining.

LJ Step 19: Valve guide wear can be checked by rocking the valve sideways in its guide. The guides should be replaced if a maximum movement of 0.35 mm is exceeded (in practice, scarcely detectable).

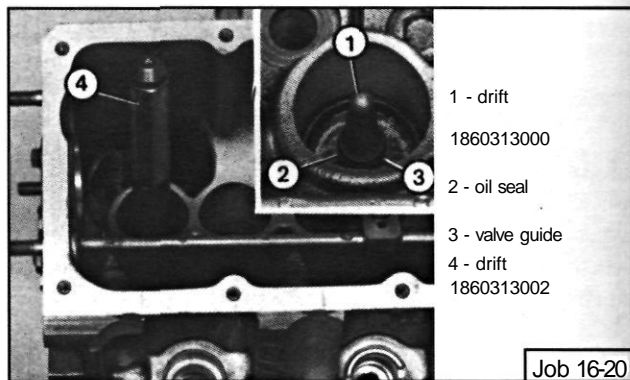

LJ Step 20: Lubricate the valve stems with clean engine oil then locate them in their respective guides after fitting new oil seals onto the tops of the guides. Take great care not to damage the seals!

making it easy! • Two specialist tools are required for seal fitting if you are to avoid damaging the new seals. These are Nos. 1860313000 and 1860313002 respectively.

• They may be available from your FIAT agent on hire, but if not it is best to take the cylinder head to the agent for the seals to be fitted.

CJ Step 21: Place the valve spring seat over the guide, then position the spring, followed by the cap. Compress the spring enough to allow you to engage the split cotters with the valve stem.

Q INSIDE INFORMATION! Use a little grease to keep them in place. Slowly release the compressor, checking that the collets are properly located. Tap the ends of the valve stems to bed them in. **Q**

LJ Step 22: Always use new camshaft end-support gaskets and fit new seals. (If the bushes inside the supports show signs of scoring, replace the supports.) Carefully remove the old seal and drift in the new. Lubricate the sealing lip before fitting the camshaft.



...and remember to lubricate all seals and moving parts with engine oil during assembly. See *Chapter 3, Facts and Figures* for specified tightening torques. • ~ ~ •

Job 17. Diesel engine. Valve clearances - adjustment.

B INSIDE INFORMATION! After carrying out **Job 16**, valve clearance measurement and adjustment is now needed. Both measurement and shim replacement are carried out in the same manner as for the petrol engine (*Job 7*), so refer to this and also to **Chapter 3, Facts and Figures** for specifications. B

Job 18. Diesel engine - removal.

This should be read in connection with *Job 8*.

B INSIDE INFORMATION! • The turbo and non-turbo diesel engines are essentially similar.

- The under-bonnet scene is in some ways different because of the extra plumbing required when a turbo is fitted.
- Locations and shapes of various items may differ, or not exist at all on the non-turbo unit.
- As most complexity is found with the turbo engine, the following illustrations are mainly of this version.
- The power units are removed from under the car, therefore make sure you can raise the car enough to achieve this. Support the car firmly and safely on axle stands. Q

LJ Step 1: Disconnect the negative lead from the battery and drain the cooling system.

U Step 2: Remove the bonnet lid.

U Step 3: Drain the transmission oil.

LI Step 4: Disconnect and remove all pipes and hoses.

LJ Step 5: Undo all electrical connection and label them with masking tape. Write matching numbers on each male and female connection to assist reconnection, later.

U Step 6: Disconnect the power steering pump pipes (where fitted), catching any spilt fluid and tie them clear. See *Job 14*.

U Step 7: Part the connection for the electronic speedometer magnetic impulse generator (when fitted).

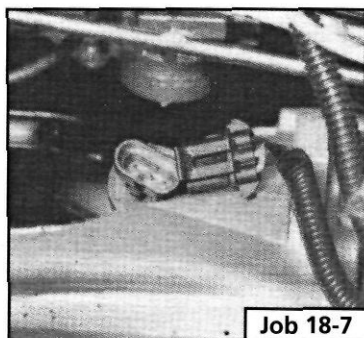

Job 18-7

fuel supply and return pipes at the injection pump...

LJ Step 9: ...and the stop control supply cable. Also disconnect the cable from the injection pump hydraulic advance control sensor and the alternator cables.



Job 18-9

• Step 10: Disconnect the oil feed and return pipes between the thermostatic valve and the radiator and tie clear.

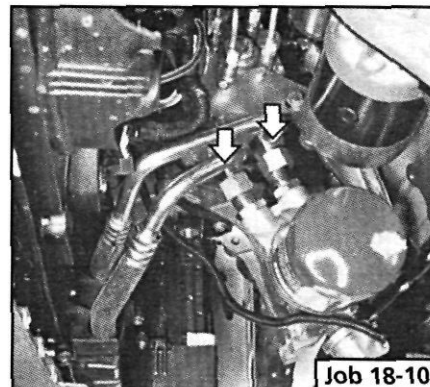

Job 18-10

[j] Step 11: Disconnect the clutch cable, adjacent earth lead and reversing light switch other cable connection from the top of the gearbox.

LJ Step 12: Disconnect the leads from the oil pressure warning light from the oil filter mounting, and the oil level warning light switch.

LJ Step 13: From under the car, remove the exhaust front section from the manifold and from its support brackets.

LJ Step 14: Remove the front road wheels and the access panel from each wheel housing.

LJ Step 15: Remove the brake pad wear sensor cables, when fitted.

LJ Step 16A: On the turbo version, undo the six 'Allen' screws securing the inboard end of each drive-shaft. Undo the two pinch bolts that fix each stub axle to the suspension struts and pull them clear. Ease the drive-shafts clear of the transmission casing - take care not to damage the protective boots.

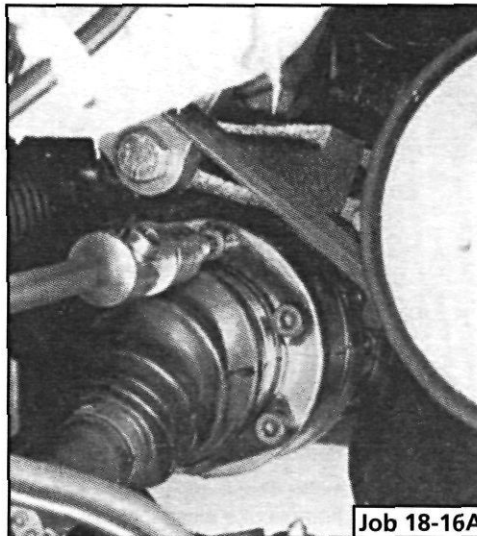

Job 18-16A

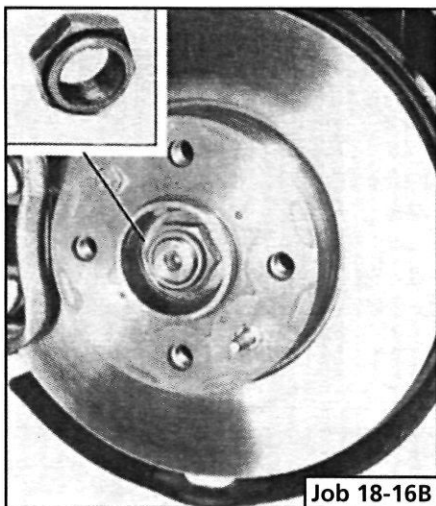

Job 18-16B

G Step 16B: Q **INSIDE INFORMATION!** On the non-turbo version, it is necessary to undo the drive-shaft-to-hub nuts. These are very tight and you will require plenty of leverage while a helper applies the footbrake very firmly to prevent hub rotation. Separate the hubs and suspension struts by removing the pinch bolts and pulling the hubs clear. Push the drive-shafts out of the hubs - leaving them fixed at the inboard ends. **Q**

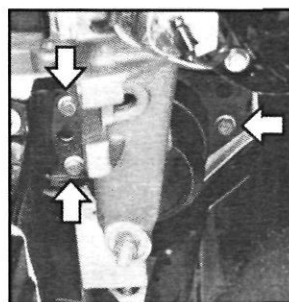
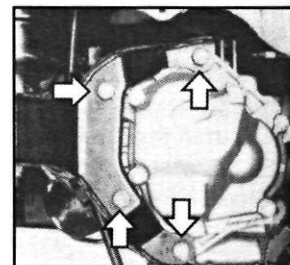
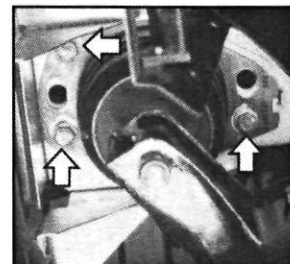
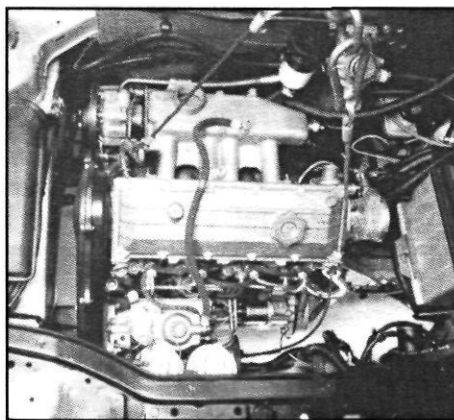

Job 18-20

• **Step 17:** Disconnect the three gearchange control rods from the gearbox brackets.

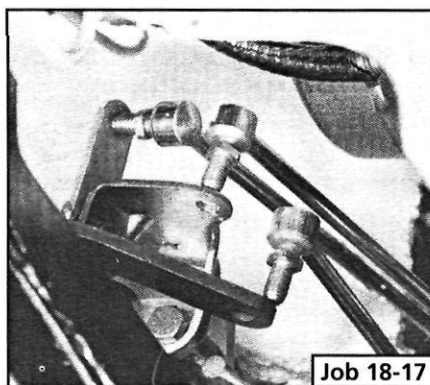

Job 18-17

LJ Step 20: Support the power unit (by means of a hook from above, or from underneath with a trolley jack and a protective piece of wood on its pad), and raise it just enough to take the weight off the mountings. Undo the fixing bolts (arrowed) and remove the mountings.

• **Step 21:** Lower the power unit to the ground, preferably onto a trolley, and retrieve from under the car.

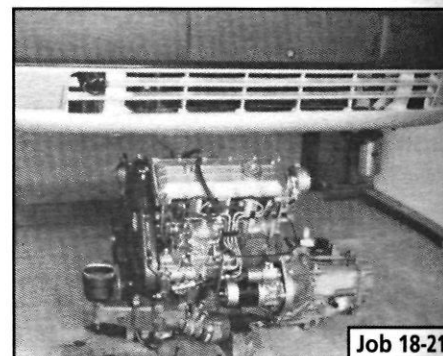

Job 18-21

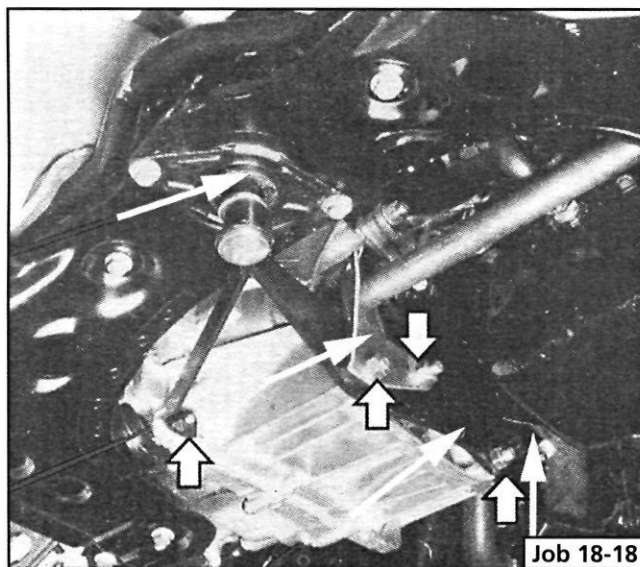

Job 18-18

U Step 18: Remove the brackets and plate (arrowed).

U Step 19: Remove the electric radiator cooling fan.

H **INSIDE INFORMATION!** For separation and reconnection of the engine/transmission, see **Jobs 21** and **22. H**

Job 19. Diesel engine - refitting.

Q Step 1: Follow the instructions for removal in reverse order, referring to *Chapter 3, Facts and Figures* for torque settings and adjustments, lubricant and coolant types and capacities.

IMPORTANT NOTE: Where the drive-shafts have been withdrawn from the hubs, new nuts must be used and staked into their grooves after tightening to the correct torque.

Q Step 2: Before starting the engine, make sure all your electrical connections are sound and your fuel, oil and coolant connections are correct and secure.

Q Step 3: Run the engine to working temperature and then allow to cool. Re-check all fluid levels.

Job 20. Diesel engine. Mountings - replacement.

See Job 12 and Job 18, Step 20.

Job 21. Diesel engine/ transmission (removed from car) - separation.

U Step 1: Remove the starter motor.

G Step 2: On the turbo version, undo the flange bolts see Job 18, Step 16A and withdraw the drive-shaft extension, if still fitted.

G Step 3: Unbolt and remove the rear engine plate and the gearbox, being careful to support the gearbox weight as it is withdrawn.

Job 22. Diesel engine/ transmission (removed from car) - reconnection.

Q Step 1: Before proceeding, check the condition of the clutch and its release mechanism. Make sure the driven plate is properly centred on the flywheel - see PART B: TRANSMISSION.

U Step 2: Now reverse the order of separation, but be careful when engaging the gearbox input shaft with the clutch driven plate that you don't 'hang' its weight on the spines. Also, see Job 11.

Job 23. Diesel engine - dismantling.

This Job should be read in conjunction with Job 5. The engines are broadly similar although the information given in this Job takes priority for diesel engines. It is MOST IMPORTANT that you read the FACT FILE on page 84.

SAFETY FIRST!

- The inside of diesel engines are particularly filthy places!
- Old diesel oil is carcinogenic!
- Wear suitable impervious gloves!

[J Step 1: Remove the timing belt and cylinder head. See Jobs 13 and 14.

Q Step 2: Remove the alternator, water pump and thermostat housing distribution pipe.

O Step 3: Remove the crankshaft timing belt sprocket.

B INSIDE INFORMATION! Note that the bolt securing the crankshaft sprocket has a left-hand thread and must be undone clockwise. **Q**

Q Step 4: Unbolt the timing belt tensioner and idler pulleys.

Q Step 5: Remove the injection pump sprocket.

Q INSIDE INFORMATION! You will need two FIAT tools for this operation. One (No. 1860473000) is to prevent the sprocket from turning when undoing the nut, and the other (extractor No. 1842128000) to pull the sprocket from the injection pump shaft. Alternatively it may be possible to improvise a means of preventing sprocket rotation, and a suitable three-leg puller may be carefully used to withdraw the sprocket. Take care not to lose the pump shaft Woodruff key. **Q**

• Step 6: Unbolt and detach the support bracket (a) from the rear of the injection pump (b). Unbolt the pump flange and bracket nuts, and remove the pump and its front bracket (c).

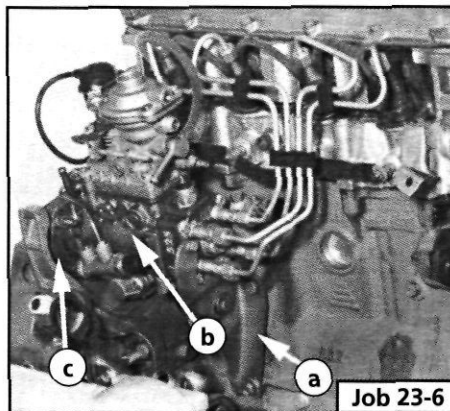

Q Step 7: Remove and discard the old oil filter.

t) Step 8: Remove the crankcase breather, the tow-oil-pressure switch and the oil pressure gauge sensor from the front face of the engine.

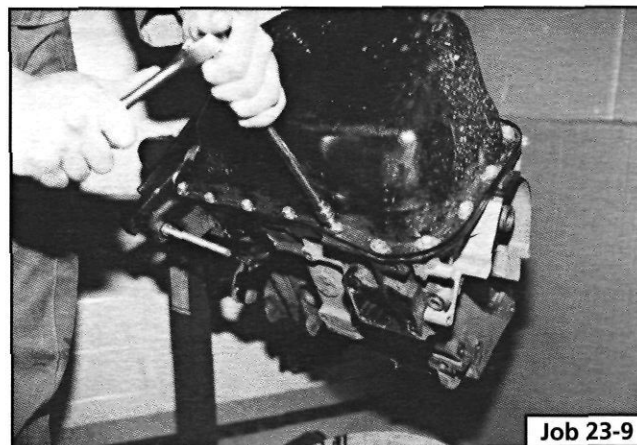

d Step 9: Turn the engine upside down and remove the flywheel and the sump.

J Step 10:
Q INSIDE INFORMATION:
The sump invariably 'glues' itself in place DON'T lever it! Use an old spatula and drive it through the gasket, cleaning it off later. **B**

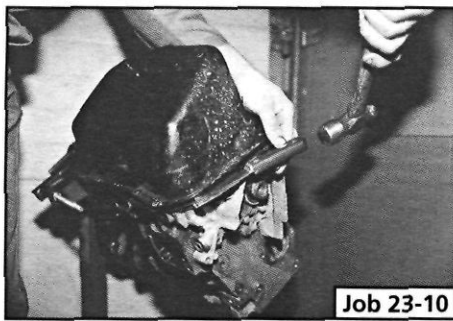

Job 23-10

• **Step 11:**
Remove the oil pick-up pipe and filter and the oil return pipe.

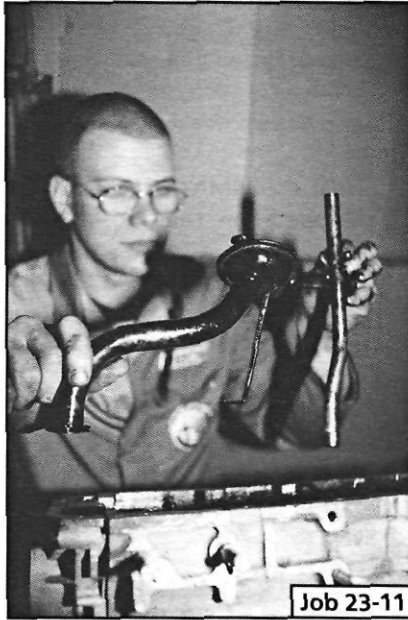

Job 23-11

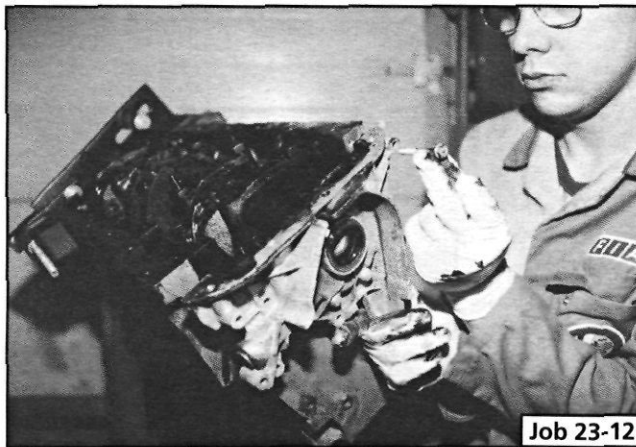

Job 23-12

Step 12: Remove the front cover and oil pump assembly...



Job 23-13

LJ Step 13: ...and the rear crankshaft seal and carrier.

• **Step 14:** Check the big-end bearing caps and the connecting rods to make sure they have matching numbers starting from the timing cover end. Otherwise, mark them with a centre punch. It is essential that you know which way round each one goes when reassembling!



Job 23-15

• **Step 15:** Undo the big-end bolts and withdraw one piston/conrod assembly, keeping it with its bearing cap.



Job 23-16

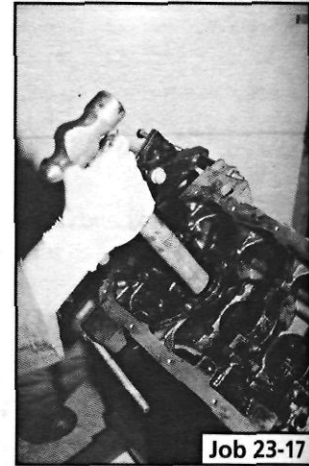

Job 23-17

L) Step 16: Keep the shell bearing halves in their original locations if they are to be reused, otherwise push them out, don't try to lift!

U Step 17: Remove the remaining piston/conrod assemblies tapping them through the tops of the bores with a hammer handle.

• **Step 18:** Check the crankshaft main bearing caps and webs to see that they are correctly numbered (by means of notches) from the timing cover end and visible from the flywheel end. Remove the caps and half-shell bearings and keep them in order.

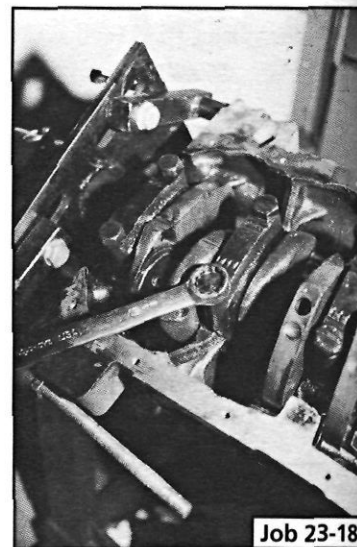

Job 23-18

Step 19:
Lift the crankshaft clear of the cylinder block, retrieve the other halves of the bearing shells...



Step 20:
...and the two thrust washers from the rear main bearing web.



Step 21:
TURBO ENGINES ONLY.
Unbolt and remove the four piston cooling sprays (a) from the cylinder block oil gallery. The bearing shell positions are arrowed.

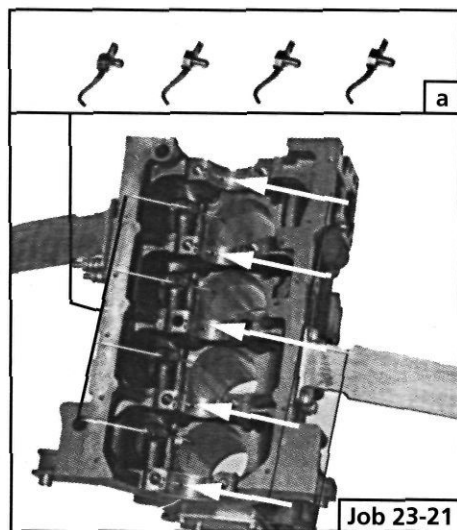

Job 24. Diesel engine - reassembly.

Before starting work, read the notes at the beginning of **Job 6** for petrol engine reassembly - the checks and preparation being basically the same for diesel engines.

INSIDE INFORMATION! TURBO ENGINES ONLY. The piston cooling sprays must be checked for serviceability before refitting. Each spray contains its own valve which must open at between 1.25 and 1.75 bar. Below this figure could cause excessive oil burning and low oil pressure. Above this figure might result in the piston overheating and its subsequent failure. Have your FIAT dealer carry out this check, and replace any faulty units if necessary. **7**

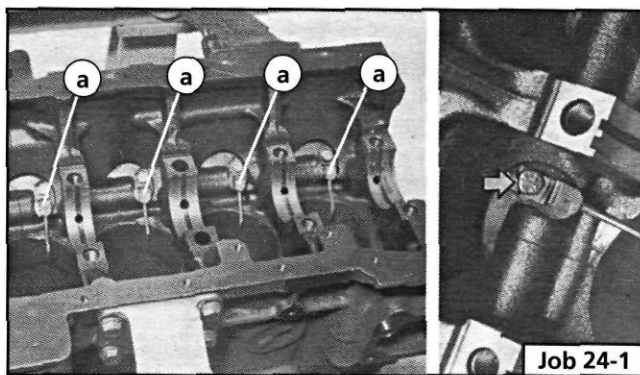

CRANKSHAFT

Step 1: TURBO ONLY: Before fitting the crankshaft, install the four piston sprays (a) and stake the retaining plates (arrowed).

Step 2: Locate the main bearing shells so that they are firmly seated and their tabs engage with the slots in the journal webs.

Step 3: Apply some grease to the smooth side of the thrust washers and 'stick' them in position on both sides of the rear main bearing web (at the flywheel end).

Step 4: Oil the shells liberally with fresh engine oil and lower the crankshaft into position.

Step 5: Fit the remaining halves of the shells into the bearing caps. Oil the journals and position the caps the right way round and in the correct order.

Step 6: Screw the bolts in finger-tight and check that the crankshaft rotates freely and smoothly.

Step 7: Tighten the bolts evenly and progressively until the specified torque setting is reached, see *Chapter 3, Facts and Figures*. Check again that the crankshaft rotates smoothly.

Step 8: Turn and lever the crankshaft tight against the timing end and check the crankshaft end float by using a feeler gauge between the thrust washer on the timing side of the web and the crankshaft. Thicker washers are available if required. See *Chapter 3, Facts and Figures*.

Step 9: Fit new oil seals to the two seal carriers.

Step 10: Fit the rear oil seal carrier (with its new seal), using a new gasket. Lubricate the seal (illustration **Job 24-9, part b**) and lightly oil the gasket (a).

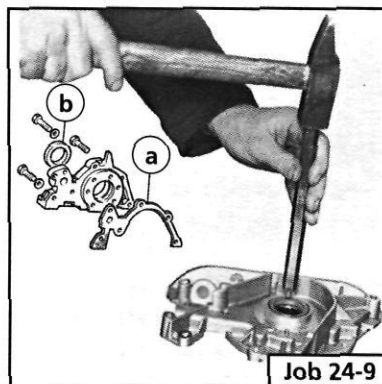

Step 11: Position Nos. 1 and 4 crank pins at Top Dead Centre (TDC), then fit the flywheel with its TDC mark facing the cylinder head surface. Screw in the fixing bolts and tighten to their specified torque. See *Chapter 3, Facts and Figures*.

LJ Step 12: Fit a new seal to the front cover/oil pump assembly, unless a new pump is being fitted, and install with a new gasket, lightly oiling both gasket and seal. Align the cover with the sump support plate.

PISTON CONNECTING RODS ASSEMBLIES

LJ Step 13:

Q INSIDE INFORMATION! Refer to the illustration and note that the piston should be fitted to the connecting rod so that when viewed from the timing end the crown lift (1) is on the right hand/injection pump (2) side. At the same time, the bore numbers stamped on the connecting rod (3) should face left, the opposite side. The piston pins are an interference fit in the pistons and can be tapped into position using an ordinary drift and secured with circlips. H

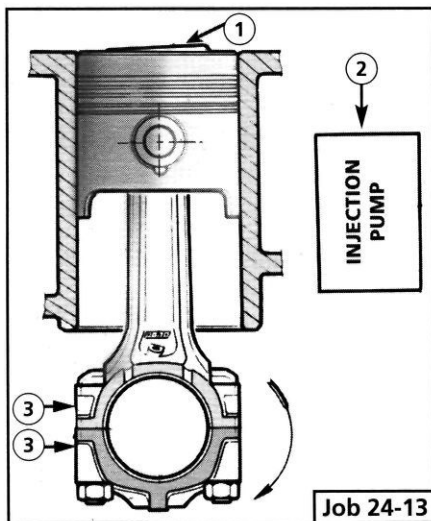

Refer to Job 6. Steps 11 to 18, for installation procedures.

CJ Step 14: Refit the oil pump pick-up and return pipes.

LJ Step 15: Refit the sump using a new gasket. Check that the drain plug is tight.

Q Step 16: Complete the reassembly by fitting all the external components in the reverse order of removal. Refer to Job 15 for cylinder head refitting.

LJ Step 17: Reconnect the engine to the transmission. See Job 22.

• **Step 18:** Refit the complete unit to the car. See Job 19.

• **Step 19:** Bleed the fuel system. See PART F: FUEL AND EXHAUST

Q INSIDE INFORMATION! Bleeding the fuel system involves turning the engine on the starter. This should allow it to gain oil pressure before 'firing up', but check that the oil light has gone out as soon as the engine starts. Q

Q Step 20: Allow the engine to run at 'fast idle' until it reaches working temperature and switch off. Allow it to cool and check the oil and coolant levels and look for any leaks.

LJ Step 21: Avoid over-rewing or overloading the engine during its settling down period of 600 miles. We recommend an oil and filter change at this mileage - this will help to extend the life of your engine.

PART B: TRANSMISSION

PART B: Contents

- Job 1. Transmission removal (with engine in car).
- Job 2. Transmission refitting (with engine in car).
- Job 3.** Clutch - replacement.
- Job 4.** Clutch cable - replacement.
- Job 5. Gear lever and linkage - removal and refitting.
- Job 6. Kickdown cable (automatic transmission) - replacement.
- Job 7. Kickdown cable (automatic transmission) - adjustment \

- Job 8. Automatic gear selector control cable - replacement.
- Job 9. Drive-shaft - removal and refitting.
- Job 10.** Drive-shaft (outer) constant velocity joint - replacement,
- Job 11. Drive-shaft inner spider joint - replacement.
- Job 12. Drive-shaft damper - replacement.
- Job 13.** Front hub/bearings - replacement..
- Job 14. Hydraulic clutch components. --^

Job 1. Transmission removal (with engine in car).

IMPORTANT NOTE: This operation is for cars fitted with the 1400 and 1600cc petrol engines and non-turbo diesel engines. For the 1930cc turbo diesel engined version the complete power unit must be removed and then separated. See PART A, Jobs 18, 19, 21 and 22 for the removal of several of the ancillaries detailed here.

• **Step 1:**

Before starting work, ensure that you can support the car sufficiently high

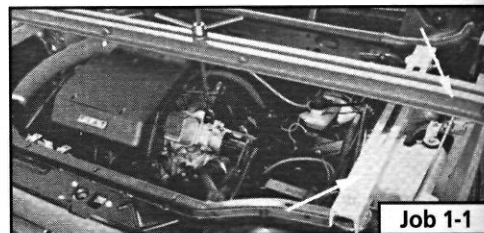

off the ground for the gearbox to be removed from beneath. Make sure that the gearbox-end of the engine is supported from above the car, or from beneath. You may be able to fabricate your own version of this FIAT tool (arrowed).

Q Step 2: Remove the bonnet. Disconnect and remove the battery.

LJ Step 3: Drain the oil from the transmission.

LJ Step 4: Disconnect the clutch cable or remove the slave cylinder, if hydraulic, from the top of the gearbox.

• Step 5: With the car still on the ground, loosen the nuts fixing the constant velocity joints to the hubs. These require an enormous force to be tightened or released (see

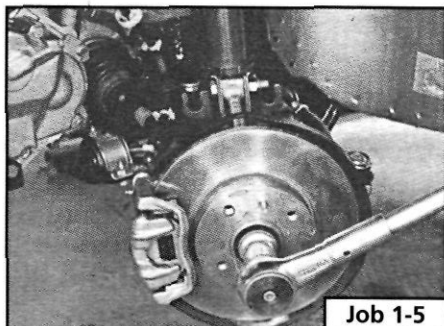

Chapter 3, Facts and Figures) and they will have been staked. There is a severe risk of pulling the car off supports if you attempt to undo these nuts while the car is raised off the ground. Slacken the front wheel nuts.

LJ Step 6: Raise the front of the car and support securely on axle stands. Remove the road wheels and the previously slackened hub nuts.

LJ Step 7: Remove the wheel arch protective shields.

LJ Step 8: Disconnect the speedometer cable from the gearbox. (If digital instrumentation, disconnect the wiring from the sender unit.)

U Step 9: Disconnect and remove the starter motor and unplug the reverse light connector and the earth lead from the transmission housing.

Q Step 10: Undo the trackrod ends securing nuts and use a suitable 'splitter' tool to part the balljoints from the steering arms. Slacken the drive-shaft inner boot securing clips. Undo the pinch bolts fixing the stub axles to the suspension struts, pull the stub axles clear and extract the drive-shafts.

LJ Step 11: Support the engine at the gearbox end, just taking the weight as described in Step 1.

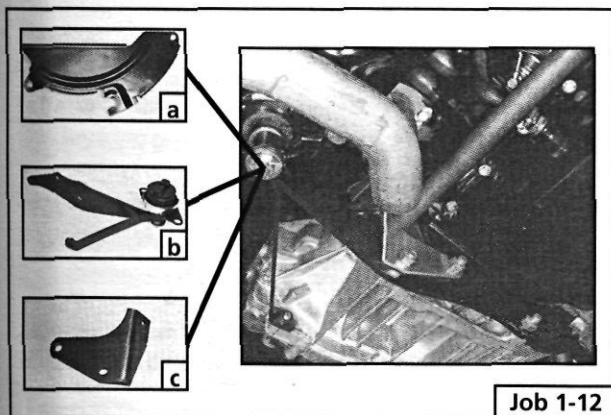

IJ Step 12: Remove the central power unit support (a), the flywheel guard (b) and the exhaust bracket (c).

LJ Step 13: Disconnect the gearchange rods at the gearbox (arrowed).

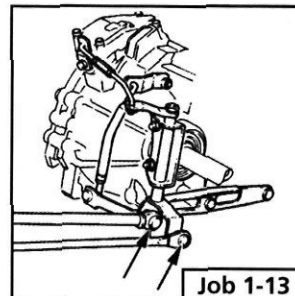

LJ Step 14: Remove the transmission mounting and bracket assembly.

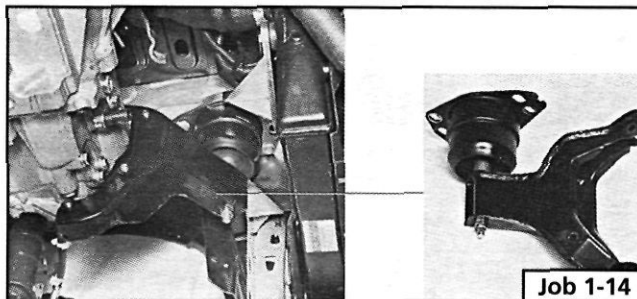

making it easy! **□ Step 15:** • Support the gearbox in such a way that when disconnecting, it can be withdrawn smoothly and without 'hanging' on the engine. A trolley jack might do the job nicely.

3 Step 16: Undo the gearbox to engine fixing bolts...



• Step 17: ...slide the box back until it's clear of the clutch and lower it to the ground using a hydraulic stand or trolley jack.

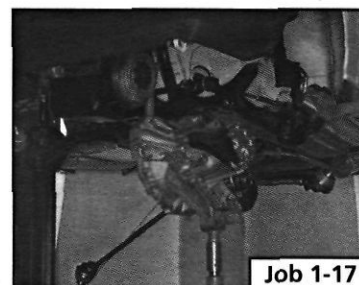

Job 2. Transmission refitting (with engine in car).

IMPORTANT NOTE: Refer to **PART A: ENGINE, Jobs 8 and 9** in connection with this Job.

Q Step 1: Refitting is the reverse of the removal work carried out in Job 1 but bear in mind the following:

Q Step 2: Centralise the clutch driven plate, if it has been disturbed. See Job 3.

• Step 3: NON-HYDRAULIC CLUTCHES ONLY. Adjust the clutch cable. See Job 4.