

Description

Almost all new automobiles produced today are required, by law, to provide an interface from which test equipment can obtain diagnostic information. The data transfer on these interfaces follow several standards, none of which are directly compatible with PCs or PDAs. The ELM327 is designed to act as a bridge between these On-Board Diagnostics (OBD) ports and standard RS232 ports.

The ELM327 builds on improved versions of our proven ELM320, ELM322, and ELM323 interfaces by adding seven CAN protocols to them. The result is an IC that can automatically sense and convert the most common protocols in use today. There are a number of other improvements as well – a high speed RS232 option, battery voltage monitoring, and customizable features through programmable parameters, to name only a few.

The ELM327 requires few external components to make a fully functioning circuit. The following pages discuss the interface details, and show how to use the IC to 'talk' to your vehicle, then concludes with two schematics to get you started.

Applications

- Diagnostic trouble code readers
- Automotive scan tools
- Teaching aids

Features

- Supports 12 protocols
- Automatically searches for a protocol
- Fully configurable with AT commands
- RS232 baud rates to 500Kbps
- Voltage input for battery monitoring
- Low power CMOS design

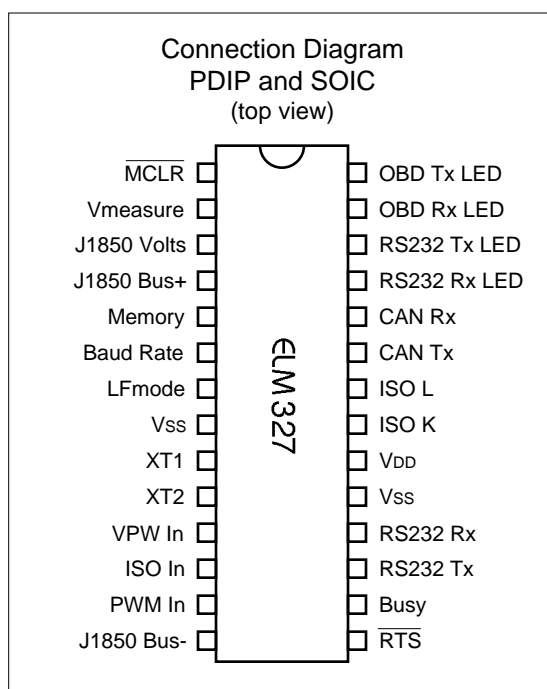

Block Diagram

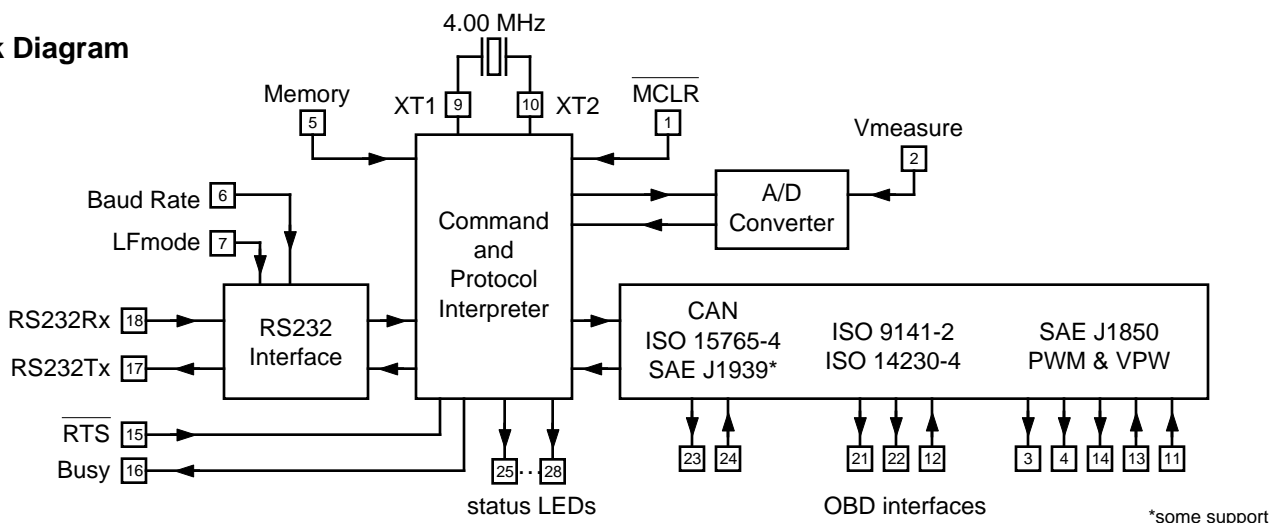



Pin Descriptions

MCLR (pin 1)

A momentary logic low applied to this input will reset the IC. If unused, this pin should be connected to a logic high (V_{DD}) level.

Vmeasure (pin 2)

This analog input is used to measure a 0 to 5V signal that is applied to it. Care must be taken to prevent the voltage from going outside of the supply levels of the ELM327, or damage may occur. If it is not used, this pin should be tied to either V_{DD} or V_{SS} .

J1850 Volts (pin 3)

This output can be used to control a voltage supply for the J1850 Bus+ output. The pin will output a logic high level when a nominal 8V is required (for J1850 VPW), and will output a low level when 5V is needed (as for J1850 PWM applications). If this switching capability is not required for your application, this output can be left open-circuited.

J1850 Bus+ (pin 4)

This active high output is used to drive the J1850 Bus+ Line to an active level. Note that this signal does not have to be used for the Bus- Line (as was the case for the ELM320), since a separate J1850 Bus- drive output is provided on pin 14.

Memory (pin 5)

This input controls the default state of the memory option. If this pin is at a high level during power-up or reset, the memory function will be enabled by default. If it is at a low level, then the default will be to have it disabled. Memory can always be enabled or disabled with the AT M1 and AT M0 commands.

Baud Rate (pin 6)

This input controls the baud rate of the RS232

interface. If it is at a high level during power-up or reset, the baud rate will be set to 38400 (or the rate that has been set by PP 0C). If at a low level, the baud rate will be 9600.

LFmode (pin 7)

This input is used to select the default linefeed mode to be used after a power-up or system reset. If it is at a high level, then by default messages sent by the ELM327 will be terminated with both a carriage return and a linefeed character. If it is at a low level, lines will be terminated by a carriage return only. This behaviour can always be modified by issuing an AT L1 or AT L0 command (see the section on AT Commands).

Vss (pins 8 and 19)

Circuit common must be connected to these pins.

XT1 (pin 9) and XT2 (pin 10)

A 4.000 MHz oscillator crystal is connected between these two pins. Loading capacitors as required by the crystal (typically 27pF each) will also need to be connected between each of these pins and circuit common (V_{SS}).

Note that this device has not been configured for operation with an external oscillator – it expects a crystal to be connected to these pins. Use of an external clock source is not recommended.

VPW In (pin 11)

This is the active high input for the J1850 VPW data signal. When at rest (bus recessive) this pin should be at a low logic level. This input has Schmitt trigger waveshaping, so no special amplification is required.

All rights reserved. Copyright 2005, 2006, and 2007 by Elm Electronics Inc.
Every effort is made to verify the accuracy of information provided in this document, but no representation or warranty can be given and no liability assumed by Elm Electronics with respect to the accuracy and/or use of any products or information described in this document. Elm Electronics will not be responsible for any patent infringements arising from the use of these products or information, and does not authorize or warrant the use of any Elm Electronics product in life support devices and/or systems. Elm Electronics reserves the right to make changes to the device(s) described in this document in order to improve reliability, function, or design.



Pin Descriptions (continued)

ISO In (pin 12)

This is the active low input for the ISO 9141 and ISO 14230 data signal. It is derived from the K Line, and should be at a high logic level when at rest (bus recessive). No special amplification is required, as this input has Schmitt trigger waveshaping.

PWM In (pin 13)

This is the active low input for the J1850 PWM data signal. It should normally be at a high level when at rest (ie. bus recessive). This input has Schmitt trigger waveshaping, so no special amplification is required.

J1850 Bus- (pin 14)

This active high output is used to drive the J1850 Bus- Line to an active (dominant) level for J1850 PWM applications. If unused, this output can be left open-circuited.

$\overline{\text{RTS}}$ (pin 15)

This active low "Request To Send" input can be used to interrupt the OBD processing in order to send a new command. Normally high, the line is brought low for attention, and should remain so until the Busy line (pin 16) indicates that the ELM327 is no longer busy. This input has Schmitt trigger waveshaping.

Busy (pin 16)

This active high output shows the current state of the ELM327. If it is at a low level, the processor is ready to receive ASCII commands and characters, but if it is at a high level, commands are being processed.

RS232Tx (pin 17)

This is the RS232 data transmit output. The signal level is compatible with most interface ICs (output is normally high), and there is sufficient current drive to allow interfacing using only a PNP transistor, if desired.

RS232Rx (pin 18)

This is the RS232 receive data input. The signal level is compatible with most interface ICs (when at idle, the level is normally high), but can be used with other interfaces as well, since the input has Schmitt trigger waveshaping.

V_{DD} (pin 20)

This pin is the positive supply pin, and should always be the most positive point in the circuit. Internal circuitry connected to this pin is used to provide power on reset of the microprocessor, so an external reset signal is not required. Refer to the Electrical Characteristics section for further information.

ISO K (pin 21) and ISO L (pin 22)

These are the active high output signals which are used to drive the ISO 9141 and ISO 14230 buses to an active (dominant) level. Many new vehicles do not require the L Line – if yours does not, you can simply leave pin 22 open-circuited.

CAN Tx (pin 23) and CAN Rx (pin 24)

These are the two CAN interface signals that must be connected to a CAN transeiver IC for proper operation. If you are connecting to an existing CAN system, the integrity of the entire system might be jeopardized if a proper interface is not used. See the Example Applications section for more information.

RS232 Rx LED (pin 25), RS232 Tx LED (pin 26), OBD Rx LED (pin 27) and OBD Tx LED (pin 28)

These four output pins are normally high, and are driven to low levels when the ELM327 is transmitting or receiving data. Current capability is suitable for directly driving most LEDs through current limiting resistors, or interfacing to other logic for status reporting. If unused, these pins should be left open-circuited.

Ordering Information

These integrated circuits are 28 pin devices, available in either a 300 mil wide plastic ('skinny') DIP format or in a 300 mil SOIC surface mount type of package. To order, add the appropriate suffix to the part number:

300 mil 28 pin Plastic DIP.....ELM327P 300 mil 28 pin SOIC.....ELM327SM



Absolute Maximum Ratings

Storage Temperature..... -65°C to +150°C
 Ambient Temperature with
 Power Applied..... -40°C to +85°C
 Voltage on V_{DD} with respect to V_{SS}..... 0 to +7.5V
 Voltage on any other pin with
 respect to V_{SS}..... -0.3V to (V_{DD} + 0.3V)

Note:
 Stresses beyond those listed here will likely damage the device. These values are given as a design guideline only. The ability to operate to these levels is neither inferred nor recommended.

Electrical Characteristics

All values are for operation at 25°C and a 5V supply, unless otherwise noted. For further information, refer to note 1 below.

Characteristic	Minimum	Typical	Maximum	Units	Conditions
Supply voltage, V _{DD}	4.5	5.0	5.5	V	
V _{DD} rate of rise	0.05			V/ms	see note 2
Average supply current, I _{DD}		9		mA	see note 3
Input threshold voltage	1.0		1.3	V	all except Schmitt inputs
Schmitt trigger input thresholds	rising	2.9	4.0	V	see note 4
	falling	1.0	1.5	V	
Output low voltage		0.3		V	current (sink) = 10 mA
Output high voltage		4.6		V	current (source) = 10 mA
Brown-out reset voltage	4.07	4.2	4.59	V	
A/D conversion time		7		msec	see note 5

Notes:

1. This integrated circuit is produced with one of Microchip Technology Inc.'s PIC18F2x8x family of devices as the core embedded microcontroller. For further device specifications, and possibly clarification of those given, please refer to the appropriate Microchip documentation (available at <http://www.microchip.com/>).
2. This spec must be met in order to ensure that a correct power on reset occurs. It is quite easily achieved using most common types of supplies, but may be violated if one uses a slowly varying supply voltage, as may be obtained through direct connection to solar cells or some charge pump circuits.
3. Device only. Does not include any load currents.
4. Pins 1, 11, 12, 13, 15 and 18 (only) have internal Schmitt trigger waveshaping circuitry. All other inputs use standard CMOS circuitry.
5. The typical width of the Busy output pulse while the ELM327 interprets the command, measures the voltage, scales it and then transmits the result of a mid-range measurement, with the RS232 rate at 38400 baud.



AT Command Summary

General Commands

BRD hh	try Baud Rate Divisor hh
BRT hh	set Baud Rate handshake Timeout
D	set all to Defaults
E0, E1	Echo Off, or On*
I	print the version ID
L0, L1	Linefeeds Off, or On
M0, M1	Memory Off, or On
WS	Warm Start (quick software restart)
Z	reset all
<CR>	repeat the last command

OBD Commands

AL	Allow Long (>7 byte) messages
AR	Automatically Receive
AT0, 1, 2	Adaptive Timing Off, Auto1*, Auto2
BD	perform a Buffer Dump
BI	Bypass the Initialization sequence
DP	Describe the current Protocol
DPN	Describe the Protocol by Number
H0, H1	Headers Off*, or On
MA	Monitor All
MR hh	Monitor for Receiver = hh
MT hh	Monitor for Transmitter = hh
NL	Normal Length messages*
PC	Protocol Close
R0, R1	Responses Off, or On
SH xyz	Set Header
SH xxyzz	Set Header
SP h	Set Protocol to h and save it
SP Ah	Set Protocol to Auto, h and save it
SR hh	Set the Receive address
ST hh	Set Timeout to hh x 4 msec
TP h	Try Protocol h
TP Ah	Try Protocol h with Auto search

* = default setting

J1850 Specific Commands (protocols 1 and 2)

IFR0, 1, 2	IFRs Off, Auto*, or On
IFR H, S	IFR value from Header or Source

ISO Specific Commands (protocols 3 to 5)

IB 10	Set the ISO Baud rate to 10400*
IB 96	Set the ISO Baud rate to 9600
IIA hh	Set the ISO (slow) Init Address to hh
KW0, KW1	Key Word checking Off, or On*
SW hh	Set Wakeup interval to hh x 20 msec
WM [1 - 6 bytes]	Set the Wakeup Message

CAN Specific Commands (protocols 6 to C)

CAF0, CAF1	Automatic Formatting Off, or On*
CF hhh	set the ID Filter to hhh
CF hhhhhhhh	set the ID Filter to hhhhhhhh
CFC0, CFC1	Flow Control Off, or On*
CM hhh	set the ID Mask to hhh
CM hhhhhhhh	set the ID Mask to hhhhhhhh
CP hh	set CAN Priority (only for 29 bit)
CS	show the CAN Status
DM1	(J1939) Monitor for DM1 messages
FC SM h	Flow Control Set the Mode to h
FC SH hhh	FC Set the Header to hhh
FC SH hhhhhhhh	FC Set the Header to hhhhhhhh
FC SD [1 - 5 bytes]	FC Set Data to [...]
MP hhhh	(J1939) Monitor for PGN hhhh

Misc. Commands

CV dddd	Calibrate the Voltage to dd.dd volts
PP xx OFF	disable Prog Parameter xx
PP FF OFF	all Prog Parameters Off
PP xx ON	enable Prog Parameter xx
PP FF ON	all Prog Parameters On
PP xx SV yy	for PP xx, Set the Value to yy
PPS	print a PP Summary
RV	Read the Voltage